

CITY OF ARCADIA

City Council Regular Meeting Agenda



Tuesday, May 7, 2024, 4:00 p.m.

**Location: Arcadia Police Department Community Room/
Emergency Operations Center (“EOC”), 250 W. Huntington Drive, Arcadia**

Pursuant to the Americans with Disabilities Act, persons with a disability who require a disability related modification or accommodation in order to participate in a meeting, including auxiliary aids or services, may request such modification or accommodation from the City Clerk at (626) 574-5455. Notification 48 hours prior to the meeting will enable the City to make reasonable arrangements to assure accessibility to the meeting.

根据《美国残障人法案》，需要调整或提供便利设施才能参加会议的残障人士（包括辅助器材或服务）可与市书记官办公室联系（电话：(626) 574-5455）。请在会前 48 小时通知市书记官办公室，以便作出合理安排，确保顺利参加会议。

Pursuant to the City of Arcadia's Language Access Services Policy, limited-English proficient speakers who require translation services in order to participate in a meeting may request the use of a volunteer or professional translator by contacting the City Clerk's Office at (626) 574-5455 at least 72 hours prior to the meeting.

根据阿凯迪亚市的语言便利服务政策，英语能力有限并需要翻译服务才能参加会议的人可与市书记官办公室联系（电话：(626) 574-5455），请求提供志愿或专业翻译服务，请至少在会前 72 小时提出请求。

How to Submit Public Comment:

Members of the Public who wish to submit public comment may do so using one of the following methods. Public comment is limited to the time and words allotted.

1. **In-Person:** Complete a Speaker Card, indicating the agenda item number and submit it to the City Clerk prior to the meeting, or simply come to the podium when the Mayor asks for those who wish to speak. Speakers shall be limited to five (5) minutes per person. At the Mayor's discretion, the time limit may be shortened to allow all speakers to address the City Council.

Electronic submission of Public Comment is also available via the City's website or by email as noted below. Public Comment submitted electronically will not be read into the record at the posted meeting time but are forwarded to the City Council prior to the meeting for consideration.

1. **Website:** Please submit your comments using our online public comment form at ArcadiaCA.gov/comment. Your comments must be received at least 30 minutes prior to the posted meeting time.
2. **Email:** Please submit your comments via email to CityClerk@ArcadiaCA.gov. Your comments must be received at least 30 minutes prior to the posted meeting time.

如何提交公众评论意见：

公众成员可以使用以下任何一种方法提交公众评论意见。请在时间和字数的限制范围内提交公众评论意见。

1. **亲自出席：**填写一张发言人卡片，注明议程项目编号，然后在会议开始前提交给市书记官，或者在市长询问公众发言时，直接到讲台上发言。每位发言人的发言时间不得超过五（5）分钟。市长可自行决定缩短发言限制时间，以便允许所有发言人向市议会表达自己的意见。

亦可按照以下方法在本市网站上或通过电子邮件以电子方式提交公众评论意见。以电子方式提交的公众评论意见不会在公布的会议期间读入记录，但会在会议开始前转交给市议会，供市议会考虑。

1. **网站：**请使用以下网站中刊载的在线公众评论意见表提交您的评论意见：ArcadiaCA.gov/comment。必须在公布的会议时间前至少提前 30 分钟提交评论意见。
2. **电子邮件：**请将您的评论意见通过电子邮件发送至：CityClerk@ArcadiaCA.gov。必须在公布的会议时间前至少提前 30 分钟提交评论意见。

CALL TO ORDER

ROLL CALL OF CITY COUNCIL MEMBERS

- April A. Verlato, Mayor
- Michael Cao, Mayor Pro Tem
- Paul P. Cheng, Council Member
- Sharon Kwan, Council Member
- Eileen Wang, Council Member

PUBLIC COMMENTS (5-minute time limit each speaker)

Any person wishing to speak before the City Council is asked to complete a Speaker Card and provide it to the City Clerk prior to the start of the meeting. Each speaker is limited to five (5) minutes per person, unless waived by the City Council. Under the Brown Act, the City Council is prohibited from discussing or taking action on any item not listed on the posted agenda.

STUDY SESSION

- a. Report, discussion, and direction regarding the proposed Operating Budget for Fiscal Years 2024-26 and Proposed Capital Improvement and Equipment Plan for Fiscal Years 2024-29.

CLOSED SESSION

- a. Pursuant to Government Code Section 54956.9 (d)(1) to confer with legal counsel regarding the matter of Aldo Perez v. City of Arcadia.

**Regular Meeting
City Council Chambers, 7:00 p.m.**

1. CALL TO ORDER

2. INVOCATION

Pastor Andre Bribiesca, Vessel Calvary Chapel Arcadia

3. PLEDGE OF ALLEGIANCE

4. ROLL CALL OF CITY COUNCIL MEMBERS

April A. Verlato, Mayor
Michael Cao, Mayor Pro Tem
Paul P. Cheng, Council Member
Sharon Kwan, Council Member
Eileen Wang, Council Member

5. REPORT FROM CITY ATTORNEY REGARDING CLOSED/STUDY SESSION ITEMS

6. SUPPLEMENTAL INFORMATION FROM CITY MANAGER REGARDING AGENDA ITEMS

7. PRESENTATIONS

- a. Presentation of an adoptable dog by Kevin McManus of the Pasadena Humane Society.
- b. Presentation of Asian American, Native Hawaiian, and Pacific Islander Mental Health Day Proclamation to Emily Wu Truong.

8. PUBLIC HEARING

Any person wishing to speak before the City Council on a public hearing item is asked to complete a Speaker Card noting the agenda item number and provide it to the City Clerk prior to the start of the public hearing. Separate and apart from the applicant (who may speak longer in the discretion of the City Council) each speaker is limited to five (5) minutes per person unless waived by the City Council. Under the Brown Act, the City Council is prohibited from discussing or acting on any item not listed on the posted agenda. The applicant may additionally submit rebuttal comments, in the discretion of the City Council.

You are hereby advised that should you desire to legally challenge in court or in an administrative proceeding any action taken by the City Council regarding any public hearing item, you may be limited to raising only those issues and objections you or someone else raised at the public hearing or in written correspondence delivered to the City Council at, or prior to, the public hearing.

- a. Resolution No. 7563 affirming the Planning Commission approval of Multiple Family Architectural Design Review No. MFADR 23-03, Tentative Tract Map No. TTM 23-05 (84291), Healthy Tree Removal No. TRH 23-04, and Protected Tree Encroachment No. TRE 23-10 for a 16-unit, contemporary style, multi-family residential condominium development at 314-326 S. Second Avenue.
CEQA: Exempt
Recommended Action: Uphold Planning Commission Approval
- b. Annual Military Equipment Report per Assembly Bill No. 481.
CEQA: Not a Project
Recommended Action: Approve

9. PUBLIC COMMENTS (5-minute time limit each speaker)

Any person wishing to speak before the City Council is asked to complete a Speaker Card and provide it to the City Clerk prior to the start of the meeting. Each speaker is limited to five (5) minutes per person, unless waived by the City Council. Under the Brown Act, the City Council is prohibited from discussing or taking action on any item not listed on the posted agenda.

10. REPORTS FROM MAYOR AND CITY COUNCIL (including reports from the City Council related to meetings attended at City expense [AB 1234]).

11. CONSENT CALENDAR

All matters listed under the Consent Calendar are considered to be routine and can be acted on by one roll call vote. There will be no separate discussion of these items unless a member of the City Council, staff, or the public requests that a specific item be removed from the Consent Calendar for separate discussion and action.

- a. Special Meeting Minutes of April 11, 2024, and Regular Meeting Minutes of April 16, 2024.
CEQA: Not a Project
Recommended Action: Approve
- b. Resolution No. 7560 approving participation in Year 4 of the Los Angeles Urban County Permanent Local Housing Allocation ("PLHA") Program; identifying proposed activities for \$966,044 in PLHA funding; and authorizing the Mayor, or designee, to sign a reimbursable contract with the Los Angeles County Development Authority ("LACDA").
CEQA: Not a Project
Recommended Action: Adopt
- c. Resolution No. 7561 amending the Fiscal Year 2023-24 Capital Improvement Program budget, authorizing a supplemental budget appropriation for the City Facilities Exterior Painting Project (Project No. 17821024) in the amount of \$26,920.33, offset by a reduction in the Capital Outlay Fund; and approve a contract with Mackone Development, Inc. for the City Facilities Exterior Painting Project in the amount of \$326,920.33.
CEQA: Exempt
Recommended Action: Adopt and Approve
- d. Professional Services Agreement with Fire Facilities, Inc. for design services for the Arcadia and United States Forest Service Joint Training Center in the amount of \$60,000.
CEQA: Not a Project
Recommended Action: Approve
- e. Contract with Express Energy Services, Inc. for the Repair Underground Field Lighting Short Project in the amount of \$38,872.76.
CEQA: Exempt
Recommended Action: Approve
- f. Contract with Carrier Corporation for the Library HVAC Unit Replacements in the amount of \$140,469.
CEQA: Exempt
Recommended Action: Approve
- g. Contract with Lexipol to provide Policy Implementation and Management Services for the Fire Department in the amount of \$40,221 and an annual subscription cost of \$12,192.
CEQA: Not a Project
Recommended Action: Approve

- h. Renewal of the Weed Abatement Services Agreement between the City of Arcadia and the Los Angeles County Agricultural Commissioner/Weights and Measures Department.
CEQA: Not a Project
Recommended Action: Approve
- i. Authorize payment of the Annual Coordinated Integrated Monitoring Program cost share in the amount of \$220,828.96 to the Rio Hondo/San Gabriel River Watershed Management Joint Powers Authority.
CEQA: Not a Project
Recommended Action: Approve
- j. Purchase Order with Black & White Emergency Vehicles, LLC for the purchase of vehicle outfitting supplies and services in the amount of \$142,695.86.
CEQA: Not a Project
Recommended Action: Approve
- k. Purchase Order with Inductive Automation, LLC for the purchase of Ignition SCADA Platform software in the amount of \$47,901.20.
CEQA: Not a Project
Recommended Action: Approve
- l. Purchase Order with Calgon Carbon Corporation for Carbon Exchange Services for the Live Oak GAC Treatment System in the amount of \$212,562.
CEQA: Exempt
Recommended Action: Approve
- m. Reject bid from Coast-to-Coast Custom Mobile, and approve a Purchase Order with Glendora Chevrolet for the purchase of one 1/2-ton 2024 Chevrolet Four-Wheel Drive Tahoe in the amount of \$76,828.
CEQA: Not a Project
Recommended Action: Approve

12. CITY MANAGER

- a. Report, discussion, and direction regarding potential modifications to the City Council meeting schedule.
CEQA: Not a Project
Recommended Action: Amend Summer Meeting Schedule

13. ADJOURNMENT

The City Council will adjourn this meeting to Tuesday, May 21, 2024, 6:00 p.m. in the City Council Conference Room.

Welcome to the Arcadia City Council Meeting!

The City Council encourages public participation, and invites you to share your views on City business.

MEETINGS: Regular Meetings of the City Council are held on the first and third Tuesday of each month at 7:00 p.m. in City Council Chambers. A full City Council agenda packet with all backup information is available at City Hall, the Arcadia Library, and on the City's website at www.ArcadiaCA.gov. Copies of individual Agenda Reports are available via email upon request (CityClerk@ArcadiaCA.gov). Documents distributed to a majority of the City Council after the posting of this agenda will be available for review at the Office of the City Clerk, 240 W. Huntington Drive, Arcadia, California. Live broadcasts and replays of the City Council Meetings are on cable television. Your attendance at this public meeting may result in the recording and broadcast of your image and/or voice as previously described.

PUBLIC PARTICIPATION: Your participation is welcomed and invited at all City Council meetings. Time is reserved at each regular meeting for those in the audience who wish to address the City Council. The City requests that persons addressing the City Council refrain from making personal, slanderous, profane, or disruptive remarks. Where possible, please submit a **Speaker Card** to the City Clerk prior to your comments, or simply come to the podium when the Mayor asks for those who wish to speak, and state your name and address (optional) for the record. Please provide the City Clerk with a copy of any written materials used in your address to the City Council as well as 10 copies of any printed materials you would like distributed to the City Council. The use of City equipment for presentations is not permitted.

MATTERS NOT ON THE AGENDA should be presented during the time designated as "PUBLIC COMMENTS." In general, each speaker will be given five (5) minutes to address the City Council; however, the Mayor, at his/her discretion, may shorten the speaking time limit to allow all speakers time to address the City Council. **By State law, the City Council may not discuss or vote on items not on the agenda. The matter will automatically be referred to staff for appropriate action or response or will be placed on the agenda of a future meeting.**

MATTERS ON THE AGENDA should be addressed when the City Council considers that item. Please indicate the Agenda Item Numbers(s) on the **Speaker Card**. Your name will be called at the appropriate time and you may proceed with your presentation within the five (5) minute time frame. The Mayor, at his/her discretion, may shorten the speaking time limit to allow all speakers to address the City Council.

PUBLIC HEARINGS AND APPEALS are items scheduled for which public input is either required or desired. Separate and apart from the applicant (who may speak longer in the discretion of the City Council), speakers shall be limited to five (5) minutes per person. The Mayor, at his/her discretion, may shorten the speaking time limit to allow all speakers to address the City Council. The applicant may additionally submit rebuttal comments.

AGENDA ITEMS: The Agenda contains the regular order of business of the City Council. Items on the Agenda have generally been reviewed and investigated by the City Staff in advance of the meeting so that the City Council can be fully informed about a matter before making its decision.

CONSENT CALENDAR: Items listed on the Consent Calendar are considered to be routine by the City Council and will be acted upon by one motion. There will be no separate discussion on these items unless a member of the City Council, Staff, or the public so requests. In this event, the item will be removed from the Consent Calendar and considered and acted on separately.

DECORUM: While members of the public are free to level criticism of City policies and the action(s) or proposed action(s) of the City Council or its members, members of the public may not engage in behavior that is disruptive to the orderly conduct of the proceedings, including but not limited to, conduct that prevents other members of the audience from being heard when it is their opportunity to speak or which prevents members of the audience from hearing or seeing the proceedings. Members of the public may not threaten any person with physical harm or act in a manner that may reasonably be interpreted as an imminent threat of physical harm. All persons attending the meeting are expected to adhere to the City's policy barring harassment based upon a person's race, religious creed, color, national origin, ancestry, physical handicap, medical condition, marital status, gender, sexual orientation, or age. The Chief of Police, or such member or members of the Police Department, shall serve as the Sergeant-at-Arms of the City Council meeting. The Sergeant-at-Arms shall carry out all orders and instructions given by the presiding official for the purpose of maintaining order and decorum at the meeting. Any person who violates the order and decorum of the meeting may be placed under arrest and such person may be prosecuted under the provisions of Penal Code Section 403 or applicable Arcadia Municipal Code section.

欢迎参加阿凯迪亚市议会会议！

市议会鼓励公众参与，并邀请您分享对城市管理的看法。

会议：市议会定期会议于每个月第一个和第三个星期二下午七时在市议会会议厅举行。在市政厅、阿凯迪亚图书馆和市政府网站 (www.ArcadiaCA.gov) 可以找到包含所有相关信息的完整市议会议程。单独的议程报告可应请求通过电子邮件索取 (CityClerk@ArcadiaCA.gov)。至于在发布该议程后向市议会多数成员分发的文件，公众可在阿凯迪亚市书记官办公室查阅，地址：**240 W. Huntington Drive, Arcadia, California**。市议会会议实况将通过有线电视进行现场直播和回放。如在以往的通知中所提示，如果您参加这次公开会议，您的图像和/或声音可能被录下并播出。

公众参与：市议会欢迎并邀请您参加市议会的所有会议。在每次定期会议上都为那些希望在会上发言的市民留出时间。市政府要求在市议会发言的人杜绝个人攻击、诽谤、亵渎或破坏性言论。如有可能，请在发表意见之前向市书记官提交一张**发言卡**，亦可在市长宣布自由发言时直接上台发言，并说出您的姓名和地址（如果您愿意），以便制作会议记录。请向市书记官提供一份您在发言中使用的任何书面材料，以及 **10** 份您希望分发给市议会的任何印刷材料。不允许把市政府设备用于准备发言内容。

议程之外的事项应当在指定的“公众评议”时间提出。在一般情况下，每位发言者将有五（5）分钟时间向市议会陈述意见，但市长可酌情缩短发言时限，以便让所有希望发言的人都有机会发言。**根据州法，市议会不得讨论或表决未列入议程的事项。此类事项将自动转给工作人员采取适当行动或作出回应，或将其列入未来会议的议程。**

列入议程的事项应当在市议会审议该事项时讨论。请在**发言卡**上标明事项的议程编号。在适当的时间会叫到您的名字，您可以在五（5）分钟时限内发言。市长可酌情缩短发言时限，以便让所有希望发言的人都有机会发言。

公开听证和上诉是为需要或希望征求公众意见的事项安排的日程。除申请人外（市议会可酌情决定延长申请人的发言时间），每位发言人的发言不得超过五（5）分钟。市长可酌情缩短发言时限，以便让所有希望发言的人都有机会发言。申请人还可以另外提交反驳意见。

议程事项：议程包含市议会的例行议题。一般而言，由市政府工作人员在会议前对议程中的事项进行审查和调查，以便市议会在作出决定之前能够充分了解情况。

同意日历：在同意日历上列出的事项被市议会视为例行公事，并将通过一项动议采取行动。除非市议员、工作人员或公众提出请求，否则不会对这些事项进行单独讨论。如果有人提出请求，该事项将从同意日历中删除，单独进行审议和采取行动。

行为规范：尽管市民可对市政府的政策和市议会或其成员的行动或拟议行动自由地提出批评，但不得出现干扰会议正常秩序的行为，包括但不限于在别人的发言时间内阻止别人发言，或妨碍公众听到发言内容或看到议程进展状况。市民亦不得威胁进行身体伤害或以可能被合理理解为作出身体伤害紧迫威胁的方式行事。所有出席会议的人都必须遵守市政府的反骚扰政策，禁止基于个人种族、宗教信仰、肤色、原国籍、祖籍、身体残障、疾病、婚姻状况、性别、性取向或年龄骚扰他人。警察局长或警察局其他成员将担任维持市议会会议秩序的保安官。保安官将执行会议主持人的一切命令和指示，以维持会议秩序和行为规范。对任何违反会议秩序和行为规范的人可执行拘捕，并可能根据《刑法典》第 403 条或《阿凯迪亚市政法典》相关条款提出起诉。



WHEREAS, following the rise in anti-Asian racism and mass shootings during the COVID-19 pandemic, it is crucial to acknowledge, celebrate and center the emotional resilience of Asian American, Native Hawaiian, and Pacific Islander communities on the local, state, and national level; and

WHEREAS, the establishment of Asian American, Native Hawaiian, Pacific Islander Mental Health Day was made by the State of California, the City and County of San Francisco, and the City of Austin, Texas on May 10, 2010, as a response to the growing awareness about mental health and promoting mental wellness in the community; and

WHEREAS, the Asian American, Native Hawaiian, and Pacific Islander community is among the fastest growing and most diverse racial groups in the United States, and have made remarkable economic, political, and social contributions; and

WHEREAS, approximately 25% of Americans experience and are diagnosed with a mental health condition each year, impacting all communities regardless of race, ethnicity, age, socioeconomic status, sexual orientation, and gender among other factors; and

WHEREAS, Asian American, Native Hawaiian, and Pacific Islanders have the lowest rates of utilization of mental health services among ethnic populations due to the substantial stigma and denial that exists as well as cultural and linguistic isolation of the community, family and individual; and

WHEREAS, raising awareness about the mental health of Asian American, Native Hawaiian, and Pacific Islander communities, past and present, encourages professional interest in health and human services professions and fosters a diversified workforce that reflects the community.

NOW, HEREOFRE, I, April A. Verlato, Mayor of the City of Arcadia, do hereby proclaim May 10, 2024, as

Asian American, Native Hawaiian, and Pacific Islander Mental Health Day

and acknowledge the importance of raising awareness about mental health in the Asian American, Native Hawaiian, and Pacific Islander communities.

*Dated this
7th Day of May, 2024*

April A. Verlato, Mayor



STAFF REPORT

Development Services Department

DATE: May 7, 2024

TO: Honorable Mayor and City Council

FROM: Jason Kruckeberg, Assistant City Manager/Development Services Director
Lisa Flores, Deputy Development Services Director
Fiona Graham, Planning Services Manager

SUBJECT: RESOLUTION NO. 7563 AFFIRMING THE PLANNING COMMISSION APPROVAL OF MULTIPLE FAMILY ARCHITECTURAL DESIGN REVIEW NO. MFADR 23-03, TENTATIVE TRACT MAP NO. TTM 23-05 (84291), HEALTHY TREE REMOVAL NO. TRH 23-04, AND PROTECTED TREE ENCROACHMENT NO. TRE 23-10 FOR A 16-UNIT, CONTEMPORARY STYLE, MULTI-FAMILY RESIDENTIAL CONDOMINIUM DEVELOPMENT AT 314-326 S. SECOND AVENUE
CEQA: Exempt
Recommendation: Uphold Planning Commission Approval

SUMMARY

At their regularly scheduled meeting on March 12, 2024, the Planning Commission held a public hearing related to Multiple Family Architectural Design Review No. MFADR 23-03 and associated applications. This project was submitted by Philip Chan on behalf of the property owner, Smart Property LA II LLC, to develop the sites located at 314-326 S. Second Avenue and construct 16 new condominium units that will be three stories in height. The Planning Commission voted 3-2 to approve the project. On March 19, 2024, Council Member Kwan requested that the project be called up for review by the City Council. At the April 16, 2024, City Council meeting, the City Council voted to call up the item and thereby, hold a de novo public hearing on the Project.

It is recommended that the City Council uphold the Planning Commission approval of the project, adopt Resolution No. 7563 (refer to Attachment No. 1); find that the project is Categorical Exempt under CEQA; and approve Multiple Family Architectural Design Review No. MFADR 23-03, Tentative Tract Map No. TTM 23-05 (84291), Healthy Tree Removal No. TRH 23-04, and Protected Tree Encroachment No. TRE 23-10, subject to the conditions listed in Resolution No. 7563.

BACKGROUND

The subject property is four adjacent lots currently developed with 16 units (four on each lot). The Applicant is requesting to demolish all 16 units, merge the existing four (4) lots together as one parcel through the tract map process, and construct 16 new condominium units that will be three-stories tall with garage parking at grade level. All the units will have four bedrooms and 5.5 bathrooms, and will range in size from 2,305 to 3,207 square feet.

The project complies with the development standards of the R-2 Zone, including, but not limited to, setbacks, height, open space, minimum parking requirements, guest parking, and bicycle spaces. No modifications or variances were requested through the application process. The proposed project requires approval of the following applications and documents:

- Tentative Tract Map No. TTM 23-05 (84291) - To merge the existing four lots and subdivide the residential units into condominiums.
- Multi-Family Architectural Design Review No. MFADR 23-03 - For the architectural design review of this project.
- Protected Tree Encroachment Permit No. TRE 23-10 and Protected Healthy Tree Removal No. TRH 23-04 - The design will encroach into the canopy of one (1) protected tree at the rear of the property and remove one (1) protected tree from the subject property.

The Project was considered by the Planning Commission at the March 12, 2024, Regular Planning Commission Meeting (refer to Attachment No. 2 for the Planning Commission staff report and resolution); staff recommended approval of this project. All the required findings were made, it was determined that the site was physically suitable for this development in the subject zoning designation, and it was found that the proposed design was compatible with the other existing multi-family developments within the surrounding neighborhood in terms of design, massing, and scale.

During the public hearing, two residents spoke in opposition to the project and submitted a letter at the hearing (refer to Attachment No. 7). Commissioner Arvizu thought the proposed development was a nice design and listed some of the elements that he thought were attractive, but he could not make one of the findings pertaining to Land Use Policy No. LU 4-1, which states that the new development will be consistent in scale, mass, and character with the other structures within the surrounding neighborhood. Commissioner Arvizu recommended that the Planning Commission deny the project on that basis. The motion failed with a 2-3 vote, with Vice Chair Wilander also voting to deny the Project. Another motion was made by Commissioner Tallerico to approve the project, and that the

Call for Review for MFADR 23-03, TTM 23-05 (84291), TRH 23-04, and TRE 23-10
(314-326 S. Second Ave.)

May 7, 2024

Page 3 of 7

proposal met all the requisite findings; the motion passed with a 3-2 vote. Refer to Attachment No. 3 for the March 12, 2024, Planning Commission Meeting Minutes.

Following Project approval on March 12, 2024, and within the 10-day appeal period, Council Member Kwan requested a City Council call for review of the Project. At the April 16, 2024, City Council Meeting, the City Council voted to call up the Project for a de novo public hearing, pursuant to the “Call for Review” process.

DISCUSSION

The proposed Project complies with all the development standards of the R-2 Zone, including, but not limited to, setbacks, height, and open space. Also, the proposed project complies with the minimum parking requirements for each of the units, guest parking, and bicycle spaces. The R-2 Zone requires a minimum density of two dwelling units per lot, and a maximum density of one unit per 3,750 square feet of lot area. This provision results in a maximum allowable density of 15 units for the combined lot area. However, in order to comply with the State’s “No Net Loss” law, at no time may a jurisdiction take action on a permit that will cause a shortfall of sites in the Regional Housing Needs Assessment (RHNA); therefore, the project must have at least 16 units, since it currently has that many units.

Tentative Tract Map

The Applicant is proposing a Tentative Tract Map to subdivide the property into detached townhomes. The proposed Tentative Tract Map complies with all provisions of the Development Code and the Subdivision Map Act. The property contains several existing easements that are used for utility purposes. The easements will either be retained or quitclaimed to accommodate the new townhomes. No dedications are required as part of the Project. Refer to Attachment No. 4 for Tentative Tract Map No. 84291.

Site Plan and Design Review

Concurrent with the subdivision application, the City Council must approve, conditionally approve, or deny the architectural design of the proposed project. The project is designed in a Contemporary architectural style – refer to Attachment No. 5 for the architectural plans and Figure 1, below.



Figure 1 – Architectural rendering of the Project as seen from 2nd Avenue.

The exterior walls of the building are proposed to be finished with a white stucco with brick veneer and vertical wood siding, which will be used to accent some exterior walls. The roof would consist of grey colored roofing tiles. Many of the elements incorporated in this design, such as the neutral tone stucco with complimentary brick veneer, pitched roof, clean lines, and articulation between the different stories, are found on properties in the neighborhood on Second Avenue and, therefore, help the project blend in with developments in the vicinity that have similar features. The Contemporary style of the buildings will provide an elevated and modern look to the immediate neighborhood, which is a mix of different architectural styles, heights, and massing. The Contemporary style mixes traditional elements with a modern flare that complements and elevates the streetscape. In addition, the front-facing balconies will not be out of character as there are other developments that also feature front-facing balconies on the street.

The massing and scale of this project will be compatible with the other multi-family developments found within this immediate neighborhood. The detached nature of the units creates the appearance of a smaller, more intimate-scale project to better blend in with existing developments in the surrounding area.

Each unit in the Project is three stories and 33 feet in height, complying with the applicable Development Standards. However, to reduce the massing of the units, the third stories are smaller than the first and second stories, and are set far back on all facades. This is especially true for the five units that front Second Avenue. For these units – Types “A” and “B” in the architectural plans – the third story will be set back 19’ and 21’-5”, respectively, from the first floor of the units. This large setback will reduce the visibility of the third stories as seen from Second Avenue. While there are no other three-story developments in the immediate area, the height of the new development will be compatible with the existing developments on Second Avenue as there are other two-story developments that have building heights at approximately 30’-0” such as the adjacent property, which features semi-subterranean parking and two stories above. In

fact, the reason the three-story allowance was added to the Code in recent years was to discourage semi-subterranean parking as a development pattern. The following is an overview of multifamily properties within the immediate area surrounding the Project:

Address and Zone	Height	Year Built
302 & 304 S. Second Ave. R-3 Zone	Approximately 30' above grade (33'-6" above basement floor) 2 stories + semi-subterranean parking	1983
162 California St. R-3 Zone	Estimated 30' 2 stories + semi-subterranean parking	1991
400 - 412 S. Second Ave. R-2 Zone	24' 2 stories	2000
405 - 411 S. Second Ave. R-3 Zone	Estimated 28' 2 stories	1993
167 & 169 El Dorado St. R-3 Zone	29'-2" 2 stories	1999
414 S. Second Ave. R-2 Zone	25'-5" 2 stories	2024

The surrounding neighborhood contains a wide range of developments including original, one-story single-family houses, new, attached multifamily townhomes, and older style condominiums with varied architectural styles and semi-subterranean parking. South Second Avenue also contains a mix of zoning, with R-3 to the west and R-2 to the east, allowing varied maximum densities for multifamily development within the immediate vicinity.

As a result, the proposed development and subdivision of condominiums would be consistent with the City’s General Plan, Multiple-Family Residential Design Guidelines, the Development Code, the State Subdivision Map Act, and would not violate any requirements of the California Regional Water Quality Control Board.

Tree Removal

The Applicant is requesting to remove one (1) protected Coast Live Oak tree on site. The tree is located in the northwest portion of the property and has a trunk diameter of 16 inches. Due to its species and size, the tree is protected per the City’s Protected Tree Ordinance and has a health rating of ‘B’ (Adequate Health but with slight decline). The tree is proposed to be removed because its roots would be severely encroached upon during construction by one of the units and there would be limited space for any future canopy growth. In addition, each of the buildings is at the minimum building separation, setbacks, and open space requirements, and accommodating the tree would result in a bulkier and less high-quality design. As a result, the tree is proposed to be removed as noted in the Arborist Report – refer to Attachment No. 6 for the Arborist Report.

In this case, there is sufficient justification for the removal of the tree. As a remedial measure, the project will be subject to Condition No. 3, which requires that two (2) replacement trees be planted as part of the project. The Applicant is proposing to plant one (1) 60" box Coast Live Oak, and two (2) additional 36" box Magnolia 'Little Gem' trees as replacements within the front yard, in order to exceed the required replacement tree requirement.

Tree Encroachment

The proposed construction of Unit 10 in the rear of the property will encroach within the protected area of one (1) Southern Magnolia tree. However, no structural excavation will be taking place within the critical root zone. The tree is expected to survive as long as the Applicant adheres to the recommendations in the Arborist Report during demolition and construction, and a Certified Arborist is required to be on-site during grading to ensure all the trees are protected – refer to Condition No. 4 in Resolution No. 7563.

It is recommended that the City Council uphold the Planning Commission's decision on the Project. This can be accomplished by adopting Resolution No. 7563. If the City Council disagrees and would like to overturn the Planning Commission decision, the City Council should state which findings cannot be met by the Project as part of the decision. A revised Resolution reflecting denial of the project would be returned at the next City Council meeting for a vote.

ENVIRONMENTAL ANALYSIS

It has been determined that the project site is less than five (5) acres; the project site has no value as a habitat for endangered, rare, or threatened species; the proposed project would not have any significant effects upon the environment, and the site can be adequately served by all the required utilities and public services. Therefore, the project is exempt under Class 32 (In-Fill Development Projects) pursuant to Section 15332 of the California Environmental Quality Act ("CEQA") Guidelines. Refer to Attachment No. 8 for the Preliminary Exemption Assessment.

PUBLIC NOTICE

Public hearing notices for the City Council's review of the Planning Commission's approval of the Project were mailed to the owners of those properties that are located within 300 feet of the subject property on April 24, 2024. As of May 2, 2024, staff did not receive any public comments on this project.

Call for Review for MFADR 23-03, TTM 23-05 (84291), TRH 23-04, and TRE 23-10
(314-326 S. Second Ave.)

May 7, 2024

Page 7 of 7

FISCAL IMPACT

Development of the project is expected to lead to increased property tax revenue as well as development impact fees; however, the fiscal impact of the Project impact is expected to be immaterial in the context of overall Citywide development.

RECOMMENDATION

It is recommended that the City Council uphold the Planning Commission's decision and approve Multiple Family Architectural Design Review No. MFADR 23-03, Tentative Tract Map No. TTM 23-05 (84291), Healthy Tree Removal No. TRH 23-04, and Protected Tree Encroachment No. TRE 23-10; state that the proposal satisfies the requisite findings; and adopt the attached Resolution No. 7563 that incorporates the requisite environmental and subdivision findings and the conditions of approval as presented in this staff report, or as modified by the City Council.

Approved:



Dominic Lazzaretto
City Manager

- Attachment No. 1: Resolution No. 7563
- Attachment No. 2: March 12, 2024, Planning Commission Staff Report and Resolution No. 2142 (without attachments)
- Attachment No. 3: March 12, 2024, Planning Commission Approved Minutes
- Attachment No. 4: Tentative Tract Map No. 84291
- Attachment No. 5: Architectural Plans
- Attachment No. 6: Arborist Report
- Attachment No. 7: Letter from Property Owner at 319 S. Second Avenue
- Attachment No. 8: Preliminary Exemption Assessment

Attachment No. 1

Resolution No. 7563

RESOLUTION NO. 7563

A RESOLUTION OF THE CITY COUNCIL OF THE CITY OF ARCADIA, CALIFORNIA, AFFIRMING THE PLANNING COMMISSION APPROVAL OF MULTIPLE FAMILY ARCHITECTURAL DESIGN REVIEW NO. MFADR 23-03, TENTATIVE TRACT MAP NO. TTM 23-05 (84291), HEALTHY TREE REMOVAL NO. TRH 23-04, AND PROTECTED TREE ENCROACHMENT NO. TRE 23-10 FOR A 16-UNIT, CONTEMPORARY STYLE, MULTI-FAMILY RESIDENTIAL CONDOMINIUM DEVELOPMENT AT 314-326 S. SECOND AVENUE

WHEREAS, on September 1, 2023, applications for Multiple Family Architectural Design Review No. MFADR 23-01, Tentative Tract Map No. TTM 23-02 (83831), and Healthy Tree Removal Permit No. TRH 23-14 were filed by Philip Chan on behalf of the property owner, Smart Property LA II LLC, for a 16 unit, three-story, contemporary style multi-family residential condominium development, a tentative tract map subdivision, and the removal of a protected Coast Live Oak Tree and encroachment into the dripline of one protected tree at 314-326 S. Second Avenue (collectively, "Project"); and

WHEREAS, on January 20, 2024, Planning Services completed an environmental assessment for the Project in accordance with the California Environmental Quality Act ("CEQA"), and recommends that the Planning Commission determine the Project is exempt under CEQA per Section 15332 of the CEQA Guidelines because the Project is considered an in-fill development project; and

WHEREAS, on March 12, 2024, a duly-noticed public hearing was held before the Planning Commission on said Project, at which time all interested persons were given full opportunity to be heard and to present evidence; and

WHEREAS, after the public hearing the Planning Commission adopted Resolution No. 2142 with a 3-2 vote approving Multiple Family Architectural Design Review No. MFADR 23-01, Tentative Tract Map No. TTM 23-02 (83831), and Healthy Tree Removal

Permit No. TRH 23-14 for a 16 unit, three-story, contemporary style multi-family residential condominium development, a tentative tract map subdivision, and the removal of a protected Coast Live Oak Tree and encroachment into the dripline of one protected tree at 314-326 S. Second Avenue, subject to the conditions of approval listed in the staff report; and

WHEREAS, on March 19, 2024, City Council Member Sharon Kwan submitted a request for the consideration of a call for review of the Planning Commission's approval of the Project; and

WHEREAS, on April 16, 2024, the City Council considered the call for review and a majority vote was obtained to formally call up the item and schedule it for a public hearing; and

WHEREAS, on May 7, 2024, a duly noticed public hearing was held before the City Council on said application, at which time all interested persons were given full opportunity to be heard and to present evidence; and

WHEREAS, based upon the entire record, including without limitation the staff report and related documents presented to the City Council, the City Council finds as follows with respect to the approval of Multiple Family Architectural Design Review No. MFADR 23-01, Tentative Tract Map No. TTM 23-02 (83831), and Healthy Tree Removal Permit No. TRH 23-14 were filed by Philip Chan on behalf of the property owner, Smart Property LA II LLC, for a 16 unit, three-story, contemporary style multi-family residential condominium development, a tentative tract map subdivision, and the removal of a protected Coast Live Oak Tree and encroachment into the dripline of one protected tree at 314-326 S. Second Avenue.

NOW, THEREFORE, THE CITY COUNCIL OF THE CITY OF ARCADIA, CALIFORNIA, HEREBY RESOLVES AS FOLLOWS:

SECTION 1. The factual data submitted by the Development Services Department in the staff report dated May 7, 2024 are true and correct.

SECTION 2. The City Council finds, based upon the entire record:

Subdivision – Tentative Tract Map

a. The proposed map, subdivision design, and improvements are consistent with the General Plan, any applicable specific plan, and the Subdivisions Division of the Development Code.

FACT: The proposed tentative tract map for a 16-unit multi-family residential condominium development and subdivision of the airspace has been reviewed for compliance with the City's General Plan and Development Code, and the Subdivision Map Act. The Project will exceed the maximum density by providing 16 residential units instead of 15 units to ensure the project complies with Government Code Section 65863 – the No Net Loss Law. The Project will not be detrimental to the General Plan Medium Density Residential Land Use designation and the R-2, Medium Density Multiple Family Residential zoning designation, respectively. These designations are intended to accommodate high density residential units such as condominiums, within the appropriate neighborhoods such as this. There is no specific plan applicable to this project.

The proposed tentative tract map complies with the Subdivision Map Act because the proposed 16-unit condominium development complies with the requirements of the Subdivisions Division of the Development Code and all other City requirements to subdivide for condominium purposes.

The Project would not adversely affect the comprehensive General Plan and is consistent with the following General Plan goals and policies:

Land Use and Community Design Element

- Policy LU-1.1: Promote new infill and redevelopment projects that are consistent with the City's land use and compatible with surrounding existing uses.
- Policy LU-4.1: Require that new multi-family residential development be visually and functionally integrated and consistent in scale, mass, and character with structures in the surrounding neighborhood.
- Policy LU-4.2: Encourage residential development that enhances the visual character, quality, and uniqueness of the City's neighborhoods and districts.

b. The site is physically suitable for the type and proposed density of development.

FACT: The site is physically suitable for this type of development and the consolidation of the four (4) lots into one (1) lot can accommodate the Project and comply with all other applicable zoning requirements, including but not limited to parking, setbacks, height, and open space. The site will provide ample amenities for residents and will be compatible with the existing neighborhood. Since the existing site has existed for many years with 16 units without detriment, the site is suitable to replace the existing density of 16 units with 16 units. Therefore, the site is physically suitable for the proposed 16-unit multi-family residential development.

c. The design of the subdivision and the proposed improvements are not likely to cause substantial environmental damage or substantially and avoidably injure fish or wildlife or their habitat.

FACT: The Project is an infill site within an urbanized area and does not serve as a habitat for endangered or rare species. Therefore, the Project would not cause substantial environmental damage or impact wildlife.

d. The design of the subdivision or type of improvements is not likely to cause serious public health or safety problems.

FACT: The Project is to subdivide the airspace of 16 units for condominium purposes. The construction would be in compliance with all applicable Building and Fire Codes to ensure public health and safety. While the proposed 16 units exceeds the calculated maximum allowed, the existing site has 16 units, therefore, allowing the same number of units as already exists will not be detrimental and shows the City's existing infrastructure would adequately serve the new development. Therefore, the development would not cause any public health or safety problems.

e. The design of the subdivision or the type of improvements will not conflict with easements acquired by the public at large for access through or use of, property within the proposed subdivision (This finding shall apply only to easements of record or to easements established by judgement of a court of competent jurisdiction and no authority is hereby granted to the review authority to determine that the public at large has acquired easements for access through or use of property within the proposed subdivision):

FACT: There are three existing six-foot wide easements that will remain for utility purposes for this Project. The Project will not conflict with these easements as no

permanent structures will be built over the easements. The 10-foot-wide utility easement that runs through the center of the property shall be quitclaimed prior to approval of the Final Tract Map. Therefore, the Project does not conflict with the existing easements, as acquired by the public at large for access through or use of property within the proposed subdivision.

f. The discharge of sewage from the proposed subdivision into the community sewer system will not result in violation of existing requirements specified by the California Regional Water Quality Control Board.

FACT: The Arcadia Public Works Services Department determined that the City's existing infrastructure would adequately serve the new development, and the requirements of the California Regional Water Quality Control Board would be satisfied.

g. The proposed design and site improvements of the subdivision conform to the regulations of the City's Development Code and the regulations of any public agency having jurisdiction by law.

FACT: The Project is in conformance with all the regulations of the City's Development Code. The Project will replace the same number of units that are on the four parcels, therefore there will be no net loss from this new development. There is no other public agency that has jurisdiction over this subject site.

Site Plan and Design Review

1. The proposed development will be in compliance with all applicable development standards and regulations in the Development Code.

FACT: The subject site is zoned the R-2, Medium Density Multiple Family Residential zoning designation, which allows for the development of accommodate

medium to high density residential units such as condominiums, within the appropriate neighborhoods such as this. The Project will exceed the maximum density by providing 16 residential units instead of 15 units to ensure the project complies with Government Code Section 65863 – the No Net Loss Law. Despite the increased density, the new Project will comply with all other applicable zoning requirements, including but not limited to parking, setbacks, height, and open space. Therefore, the new development will be in compliance with all the applicable standards and regulations in the Development Code.

2. The proposed development will be consistent with the objectives and standards of the applicable Design Guidelines.

FACT: The proposed development is located within the Medium Density Residential (R-2) Zone, which is intended to provide a variety of medium to high density residential developments. The proposed design of the 16-unit condominium project is compatible with existing multi-family developments in the surrounding neighborhood in terms of design, massing, and scale. The proposed Contemporary architectural style would be compatible with other existing multi-family developments along Second Avenue as the neighborhood is eclectic with no dominant architectural style. While this will be the first of this style on this block, the style provides an elevated and modern look to the neighborhood and the detached buildings help to reduce the physical mass of the development. The project features five (5) buildings oriented towards the site's primary public street to help define the street frontage and pedestrian areas. The project features extensive landscaping including the planting of 13 new 36-inch box trees in the front yard and maintaining the three mature Magnolia trees which help further mitigate the mass and scale from the street. The architectural elements incorporated in this design, such as

neutral toned stucco, tile roofing, and brick veneer, are consistent with developments in the vicinity that have similar features. Additionally, the massing and scale of the new development will not be out of character with developments in the vicinity as many of the existing multi-family developments, despite being two-stories, are around 30' 0" in height. The adjacent building is three stories with a semi-subterranean floor and attached garage and total height of 33'-6". In addition, the proposed buildings have articulation on all facades which provides visual interest and reduces massing. Therefore, the proposed development will be consistent with the objectives and standards of the Multi-Family Design Guidelines.

3. The proposed development will be compatible in terms of scale and aesthetic design with surrounding properties and developments.

FACT: The new two-story home would be compatible with the character of the neighborhood in terms of the architectural design of multi-family developments along Second Avenue as the neighborhood is eclectic with no dominant architectural style. The Contemporary style development is consistent with the City's design guidelines in terms of form, roof, articulations, and design features and details. The third story of the building is stepped back 20' from the ground floor to make the building appear less imposing at the pedestrian level and more compatible with the existing neighborhood which is made up of a mix of one and two-story developments and one other three story development directly north of the property. The high pitch roof and gables on the second story hides a large portion of the third story at the front and sides of the buildings and the articulation between the floors serves to further reduce the visual mass of the home. Directly behind the project, there is a townhouse development with units that are larger in square footage

than the average unit size of the Project and the next lot over has unit sizes of 2,700 square feet and greater, therefore, the scale of the project will not be out of line with the adjacent multifamily developments. Of the units that front Second Street, the building frontage length is similar in length to other developments that also front Second Street which is approximately 31'-0" in linear length. The design also incorporates traditional architectural elements to better blend the style in the surrounding area while the wood paneling and overall neutral palette, and white brick veneer give it a unique modern flair. There are design variations for each of the townhouses which help to provide a variation between the homes and give an appearance more akin to a single-family home rather than a large complex. The architectural design, overall articulation, extensive front yard landscaping including retention of three large, existing Magnolia trees, and large third story setbacks help minimize the scale, soften the appearance of the home, and allow for consistency with the neighborhood. The City's Planning Division found that the Contemporary architectural style is appropriate for the neighborhood, that the development had sufficient articulation, and that the façade detailing, windows and doors, and colors and materials are suitable for the style and compatible with the surrounding properties and developments.

4. The proposed development will have an adequate and efficient site layout in terms of access, vehicular circulation, parking and landscaping.

FACT: The proposed development will have an adequate site layout as the site will have one access driveway for ingress and egress from Second Avenue. The driveway is sufficiently set back from the street and will allow for easy vehicular ingress and egress to the site which will prevent any cars from backing up onto the street. Each of the units

will have a 20' x 20' two-car garage that will be accessed from the shared driveway. Each of the garages will meet the required 25'-0" backout space. The site will also comply with the minimum guest parking spaces of eight (8) parking spaces, and a bike rack for eight (8) spaces will be located on the north side of the property adjacent to the pedestrian entry on Second Avenue. The proposed landscaping will complement the architectural design, provide screening along all sides, including trees and shrubs fronting Second Avenue and large hedges along the side and rear property lines, and is consistent with landscaping in the neighborhood.

5. The proposed development will be in compliance with all of the applicable criteria identified in Subparagraph 9107.19.040.C.5 for a Site Plan and Design Review application.

FACT: The proposed project would be in compliance with all the applicable criteria set forth in Subparagraph 9107.19.040.C.5, including all other applicable sections of the Development Code. The project is in compliance with the City's Multi-Family Residential Design Guidelines as the proposed home will have an appropriate mass, scale, and design that fits in with the other homes in the immediate vicinity. The project complies with all other applicable zoning requirements, including but not limited to parking, setbacks, height, and open space. The site will provide ample amenities for residents including both private and common open space and will be compatible with the existing neighborhood. The site layout and design are harmonious with the neighborhood as the proposed development meets or exceeds all required setbacks. The visual mass of the home is softened by "hiding" the third story within the roof at the front of the house. Extensive new landscaping throughout will complement the development and provide

additional screening along both side and the rear property lines. The driveway for the site is designed to provide efficient and safe access to the residents and neighbors. No major impacts on or off-site are expected from this project. Therefore, the proposed home will be consistent with the City's Multi-Family Residential Design Guidelines and General Plan.

Removal of a Healthy Protected Tree and Encroachment into the Protected Zone of a Protected Tree

h. Removal of a Healthy Protected Tree and Encroachment into a Protected Tree

FACT: The removal of the protected Coast Live Oak tree is necessary since it will not survive due to the proposed grading and excavation for one of the units and that the construction will severely damage the roots and there would be limited space for any future canopy growth. The proposed encroachment within the dripline of the protected tree (Southern Magnolia tree) is also necessary for the construction of one of the units in the rear of the property, however, the potential impacts of the construction of the units and proposed improvements will not harm the health of the tree, and its long-term health since the tree will not be within the area of structural excavation of one of the units and the Applicant shall be required to follow all protection measures within the Arborist report. Therefore, the removal of a healthy protected tree and encroachment into the dripline of a protected tree are warranted to accommodate the proposed development.

SECTION 3. Pursuant to the provisions of the California Environmental Quality Act ("CEQA"), this Project is a Class 32 Categorical Exemption as an infill-development project per Section 15332 of the CEQA Guidelines.

SECTION 4. For the foregoing reasons the City Council affirms the Planning Commission's determination that the Project is Categorically Exempt under the California Environmental Quality Act ("CEQA") Section 15332, Class 32, and the Planning Commission's approval of Multiple Family Architectural Design Review No. MFADR 23-03, Tentative Tract Map No. TTM 23-05 (84291), Healthy Tree Removal No. TRH 23-04, and Protected Tree Encroachment No. TRE 23-10 for a 16-unit, contemporary style, multi-family residential condominium development and the removal of one protected tree and the encroachment into the protected zone of one protected tree at 314-326 S. Second Avenue, subject to the conditions of approval attached hereto.

SECTION 5. The City Clerk shall certify to the adoption of this Resolution.

[SIGNATURES ON THE NEXT PAGE]

Passed, approved and adopted this 7th day of May, 2024.

Mayor of the City of Arcadia

ATTEST:

City Clerk

APPROVED AS TO FORM:

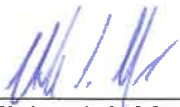

Michael J. Maurer
City Attorney

Page Intentionally Left Blank

RESOLUTION NO. 7563

Conditions of Approval

1. The project shall be developed and maintained by the Applicant/Property Owner in a manner that is consistent with the plans submitted and conditionally approved for Multiple Family Architectural Design Review No. MFADR 23-03, Tentative Tract Map No. TTM 23-05 (84291), Healthy Tree Removal No. TRH 23-04, and Protected Tree Encroachment No. TRE 23-10, subject to the approval of the Deputy Development Services Director, or designee.
2. Any required mechanical equipment, such as backflow devices, visible from the public right-of-way shall be screened from public view. Screening may include landscaping, solid walls or other methods deemed appropriate for the development. The placement and height of said screening shall be subject to review and approval by the Deputy Development Services Director, or designee.
3. The Applicant/Property Owner shall plant a 60" box Coast Live Oak tree and two 36-inch box Magnolia "Little Gem" trees within the front yard area as part of the replacement trees for the removal of the healthy protected tree. These trees must be shown on the final landscape plan. The Applicant/Property Owner shall also comply with all the measures listed in the Arborist Report, dated December 9, 2023. During construction, a Certified Arborist shall be on-site to monitor and ensure proper placement of the new replacement trees as well as survival of the existing protected Southern Magnolia tree. A follow-up report shall be submitted to the City prior to issuance of a Certificate of Occupancy.
4. The Applicant/Property Owner shall comply with all the measures listed in the Arborist Report, dated December 9, 2023. If the Certified Arborist determines that the tree may not survive at the time the follow-up report is prepared, then the Applicant shall plant a new 36-inch box tree on the subject site prior to issuance of a Certificate of Occupancy. The location and type shall be approved by the Deputy Development Services Director or designee.
5. The project shall comply with the latest adopted edition of the following codes as applicable:
 - a) California Building Code
 - b) California Electrical Code
 - c) California Mechanical Code
 - d) California Plumbing Code
 - e) California Energy Code
 - f) California Fire Code
 - g) California Green Building Standards Code
 - h) California Existing Building Code
 - i) Arcadia Municipal Code

6. The project shall comply with Chapter 35A Multiple Family Construction Standards as amended in the Arcadia Municipal Code Section 8130.20.
7. All utility conductors, cables, conduits and wiring supplying electrical, cable and telephone service to a multiple family building shall be installed underground except risers which are adjacent to and attached to a building.
8. A grading plan shall be prepared by a registered civil engineer and approved by the City prior to issuance of a building permit. The grading plans shall indicate all on- and off-site improvements and shall indicate complete drainage paths of all drainage water run-off.
9. A demolition permit shall be obtained from Building Services prior to the removal and/or demolition of the structures on site.
10. Prior to approval of the Tract Map, the Applicant/Property Owner shall:
 - a. Remove existing driveway approaches and construct new driveway approach per the City's standards.
 - b. Remove and replace new sidewalk providing adequate path of travel in compliance with Americans with Disabilities Act ("ADA"). Ensure locations around obstructions provide necessary clearances.
 - c. Remove and replace curb and gutter with 2' asphalt slot cut from property line to property line along the property frontage of Second Avenue.
 - d. The 10-foot easement that is owned by Southern California Edison shall be quitclaimed and a copy of the recordation shall be submitted to the City prior to filing the final tract map.
11. The Applicant/Property Owner shall submit a Low Impact Development ("LID") plan for this project, and it shall comply with the Los Angeles County Department of Public Works 2014 LID standard Manual and show the selected measures on the grading plan. These selected measures include, but are not limited to using infiltration trenches, bio-retention planter boxes, roof drains connected to a landscaped area, pervious concrete/paver, etc.
12. Prior to receiving a Certificate of Occupancy, the Applicant/Property Owner shall repair any damages caused by the development to the asphalt street frontages from property line to property line including but not limited to trench cuts and construction traffic, as determined by the City Engineer.
13. There is a 12-inch ductile iron water main with 80 psi static pressure that the development shall connect to on Second Avenue. for domestic water and/or fire services. The Applicant/Property Owner shall provide calculations to the Public Works Services Department to determine the total combined maximum domestic and fire demand and verify the water service size required prior to issuance of a Building Permit.

14. The Applicant/Property Owner shall install a common master water meter for the residential multi-family development. The water meter for each unit can be used to supply both domestic water services and fire services. The Applicant/Property Owner shall separate the fire service from domestic water service with an approved back flow device.
15. A separate water service and meter shall be required for common area landscape irrigation. A reduced pressure backflow device shall be installed.
16. Fire protection requirements shall be as stipulated by the Arcadia Fire Department and shall be conformed to Arcadia Standard Plan. A separate fire service with Double Check Detector Assembly ("DCDA") shall be installed for fire service if required.
17. A Water Meter Permit Application shall be submitted to the Public Works Services Department prior to issuance of a building permit for the new development.
18. New water service installations shall be by the Applicant/Property Owner. Installation shall be according to the specifications of the Public Works Services Department, Engineering Section. Abandonment of existing water services, if necessary, shall be by the Applicant/Property Owner, according to Public Works Services Department.
19. An 8" Vitrified Clay Pipe ("VCP") sewer line is available on Second Avenue to provide sanitary sewer service for the project. The Applicant/Property Owner shall utilize the existing sewer lateral, if possible. If there are any changes to the existing sewer lateral, the Applicant/Property Owner shall obtain approval from the Los Angeles County Sanitation District to connect to the exiting sewer main prior to commencing work, and obtain an encroachment permit from City of Arcadia.
20. If any drainage fixture elevation is lower than the elevation of next upstream manhole cover, an approved type of backwater valve is required to be installed on the lateral at the right-of-way and it shall be reviewed and approved by the Public Works Department prior to issuance of a building permit.
21. The Applicant/Property Owner shall file a Notice of Intent ("NOI") with the State Water Resources Control Board for a General Construction NPDES Permit and pay applicable fees to the State Water Resources Control Board.
22. The Applicant/Property Owner shall prepare a Storm Water Pollution Prevention Plan (SWPPP) as part of the General Construction Permit requirements prior to issuance of a building permit.
23. All structures shall be provided with an automatic fire sprinkler system per the City of Arcadia Fire Department Single & Multi-Family Dwelling Sprinkler Standard.
24. A Knox box shall be provided adjacent to the pedestrian and vehicle gates so that

the pedestrian and vehicle entry gate shall be openable without a special key for the City of Arcadia Fire Department.

25. The Applicant/Property Owner shall comply with all City requirements regarding building safety, fire prevention, detection, suppression, emergency access, public right-of-way improvements, parking, water supply and water facilities, sewer facilities, trash reduction and recycling requirements, and National Pollutant Discharge Elimination System ("NPDES") measures to the satisfaction of the Building Official, Fire Marshal, Public Works Services Director, and Deputy Development Services Director, or their respective designees. Compliance with these requirements is to be determined by having fully detailed construction plans submitted for plan check review and approval by the foregoing City officials and employees.
26. To the maximum extent permitted by law, Applicant must defend, indemnify, and hold the City, any departments, agencies, divisions, boards, and/or commissions of the City, and its elected officials, officers, contractors serving as City officials, agents, employees, and attorneys of the City ("Indemnitees") harmless from liability for damages and/or claims, actions, or proceedings for damages for personal injuries, including death, and claims for property damage, and with respect to all other actions and liabilities for damages caused or alleged to have been caused by reason of the Applicant's activities in connection with MFADR 23-03, TTM 23-05 (84291), TRH 23-04, TRE 23-10 ("Project") on the Project site, and which may arise from the direct or indirect operations of the Applicant or those of the Applicant's contractors, agents, tenants, employees or any other persons acting on Applicant's behalf, which relate to the development and/or construction of the Project. This indemnity provision applies to all damages and claims, actions, or proceedings for damages, as described above, regardless of whether the City prepared, supplied, or approved the plans, specifications, or other documents for the Project.

In the event of any legal action challenging the validity, applicability, or interpretation of any provision of this approval, or any other supporting document relating to the Project, the City will notify the Applicant of the claim, action, or proceedings and will cooperate in the defense of the matter. The Applicant must indemnify, defend and hold harmless the Indemnitees, and each of them, with respect to all liability, costs and expenses incurred by, and/or awarded against, the City or any of the Indemnitees in relation to such action. Within 15 days' notice from the City of any such action, the Applicant shall provide to the City a cash deposit to cover legal fees, costs, and expenses incurred by City in connection with defense of any legal action in an initial amount to be reasonably determined by the City Attorney. The City may draw funds from the deposit for such fees, costs, and expenses. Within 5 business days of each and every notice from the City that the deposit has fallen below the initial amount, Applicant/Property Owner shall replenish the deposit each and every time in order for City's legal team to continue working on the matter. The City shall only refund to the Applicant/Property Owner any unexpended funds from the deposit within 30 days of: (i) a final, non-appealable decision by a court of competent

jurisdiction resolving the legal action; or (ii) full and complete settlement of legal action. The City shall have the right to select legal counsel of its choice. The parties hereby agree to cooperate in defending such action. The City will not voluntarily assist in any such third-party challenge(s). In consideration for approval of the Project, this condition shall remain in effect if the entitlement(s) related to this Project is rescinded or revoked, at the request of the Applicant or not.

27. Approval of for Multiple Family Architectural Design Review No. MFADR 23-03, Tentative Tract Map No. TTM 23-05 (84291), Healthy Tree Removal No. TRH 23-04, and Protected Tree Encroachment No. TRE 23-10 shall not be in effect unless the Property Owner and Applicant have executed and filed the Acceptance Form with the City on or before 30 calendar days after the City Council has adopted the Resolution. The executed Acceptance Form submitted to the Development Services Department is to indicate awareness and acceptance of the conditions of approval.

Attachment No. 2

March 12, 2024 Planning Commission Staff
Report and Resolution No. 2142
(without attachments)



STAFF REPORT

Development Services Department

DATE: March 12, 2024

TO: Honorable Chairman and Planning Commission

FROM: Lisa L. Flores, Deputy Development Services Director
Prepared By: Alison MacCarley, Assistant Planner

SUBJECT: RESOLUTION NO. 2142 - APPROVING MULTIPLE FAMILY ARCHITECTURAL DESIGN REVIEW NO. MFADR 23-03, TENTATIVE TRACT MAP NO. TTM 23-05 (84291), HEALTHY TREE REMOVAL NO. TRH 23-04, AND PROTECTED TREE ENCROACHMENT NO. TRE 23-10 FOR A 16-UNIT, CONTEMPORARY STYLE, MULTI-FAMILY RESIDENTIAL CONDOMINIUM DEVELOPMENT AT 314-326 S. SECOND AVENUE

CEQA: Exempt

Recommendation: Adopt

SUMMARY

The Applicant, Philip Chan, on behalf of the property owner, Smart Property LA II LLC, is requesting approval of Multiple Family Architectural Design Review No. MFADR 23-03, Tentative Tract Map No. TTM 23-05 (84291), Healthy Tree Removal No. TRH 23-04, and Protected Tree Encroachment No. TRE 23-10 for a 16-unit, three-story, Contemporary style multi-family residential condominium development at 314-326 S. Second Avenue. The proposed development and subdivision are consistent with the City's General Plan, Development Code, and Subdivision Map Act. It is recommended that the Planning Commission adopt Resolution No. 2142 (refer to Attachment No. 1) and find that the project is Categorically Exempt under CEQA and approve Multiple Family Architectural Design Review No. MFADR 23-03, Tentative Tract Map No. TTM 23-05 (84291), Healthy Tree Removal No. TRH 23-04, and Protected Tree Encroachment No. TRE 23-10, subject to the conditions listed in this staff report.

BACKGROUND

The subject site consists of four parcels: 314 S Second Avenue, 320 S. Second Avenue,

324 S. Second Avenue, and 326 S. Second Avenue. The combined square footage of the lots will be approximately 59,440 square feet. The interior lots are located on the east side of Second Avenue, between California Street and El Dorado Avenue. The northernly two lots, 314 S. Second Avenue and 320 S. Second Avenue, share a driveway between them and the two southernly lots, 324 S. Second Avenue and 326 S. Second Avenue also shares a driveway between them. Although there are four separate legal lots, they function as one big complex with shared open space, driveway, etc. The properties are zoned R-2, Medium Density Multiple Family Residential, with a General Plan Land Use Designation of Medium Density Residential. The properties are surrounded by R-2 zoned properties to the south and east and R-3, High Density Multiple Family Residential properties to the north and west.

Each lot has four (4) residential units, two detached duplexes, with a total of 16 units on all four lots. At 314 Second Avenue, the front unit was built in 1954 and the rear unit was built in 1956. At 320 S. Second Avenue, both structures were built in 1959, and the structures at 324 S. Second Avenue and at 326 S. Second were all built in 1960, refer to Attachment No. 2 for an Aerial photo with Zoning Information and Photos of the Subject Properties and Figure 1.

Based on the evaluation by an Architectural Historian, the properties do not meet any of the minimum requirements for designation as a historical resource under federal, state and local criteria. The residences are not a good example of any particular architectural style and are not representative of or associated with any important historical events or people. The structures have not yet been demolished due to the City's replacement policy for residential projects, which requires approval of a new project prior to demolition of the structures on site.





Figure 1 – Existing Residences at 314-316 S. Second Avenue (top) and 324-326 S. Second Avenue (bottom)

PROPOSAL

The Applicant is requesting to demolish all 16 structures on the properties, merge the lots together as one parcel through the tract map process, and construct 16 new condominium units that will be three-stories tall with garage parking at grade level – refer to Attachment No. 3 for the Tentative Tract Map and Attachment No. 4 for the proposed Architectural Plans. The proposed architectural style will be Modern-Contemporary which incorporates many architectural elements found within the neighborhood. While this will be the first of this style on this block, the style provides an elevated and modern look to the neighborhood and the detached building helps to reduce the physical mass of the development. The upper levels of the buildings are stepped back from the ground floor to make the building appear less imposing at the pedestrian level and more compatible with the existing neighborhood which is made up of a mix of one- and two-story developments. The design also incorporates traditional architectural elements to better blend the style in the surrounding area while the wood paneling and overall neutral palette, and white brick veneer give it a unique modern flair. The designs vary slightly so they are not identical and help to provide a variation between the homes and to prevent the development from having a singular design throughout the site. Although there is no dominant architectural style in the area, the design would be compatible with the existing multi-family developments in the neighborhood, as it incorporates elements seen on nearby homes such as neutral toned stucco, tile roofing, clean lines, and brick veneer (see Figure 2).



Figure 2 – 314 -326 S. Second Avenue Rendering

All units will have four bedrooms and 5.5 bathrooms that range from 2,305 square feet to 3,207 square feet in size. Each of the units will have pedestrian access off Second Avenue through a walkway on the northwest side of the property refer to Figure 3 below.

The site will have one access driveway for ingress and egress from Second Avenue. Each of the units will have a 20' x 20' two-car garage that will be accessed from the shared driveway. Each of the garages will meet the required 25'-0" backout space. The site will also comply with the minimum guest parking spaces of eight (8) parking spaces, and a bike rack for eight (8) spaces will be located on the north side of the property adjacent to the pedestrian entry on Second Avenue.

The proposed development will have an overall building height of 33', which is the maximum allowed height for a building with a pitched roof. The development complies with all the minimum setback requirements. Fifteen of the units will have their own private open space in the side and/or rear of the units, and one unit, Unit 11, will have 132 square foot balcony which complies with the minimum requirements of being greater than 30 inches in width and depth as their private open space. The property will also feature 633 square feet of common open space towards the rear of the property in front of Units 10 and 12, which features benches and an outdoor gas grill for residents.

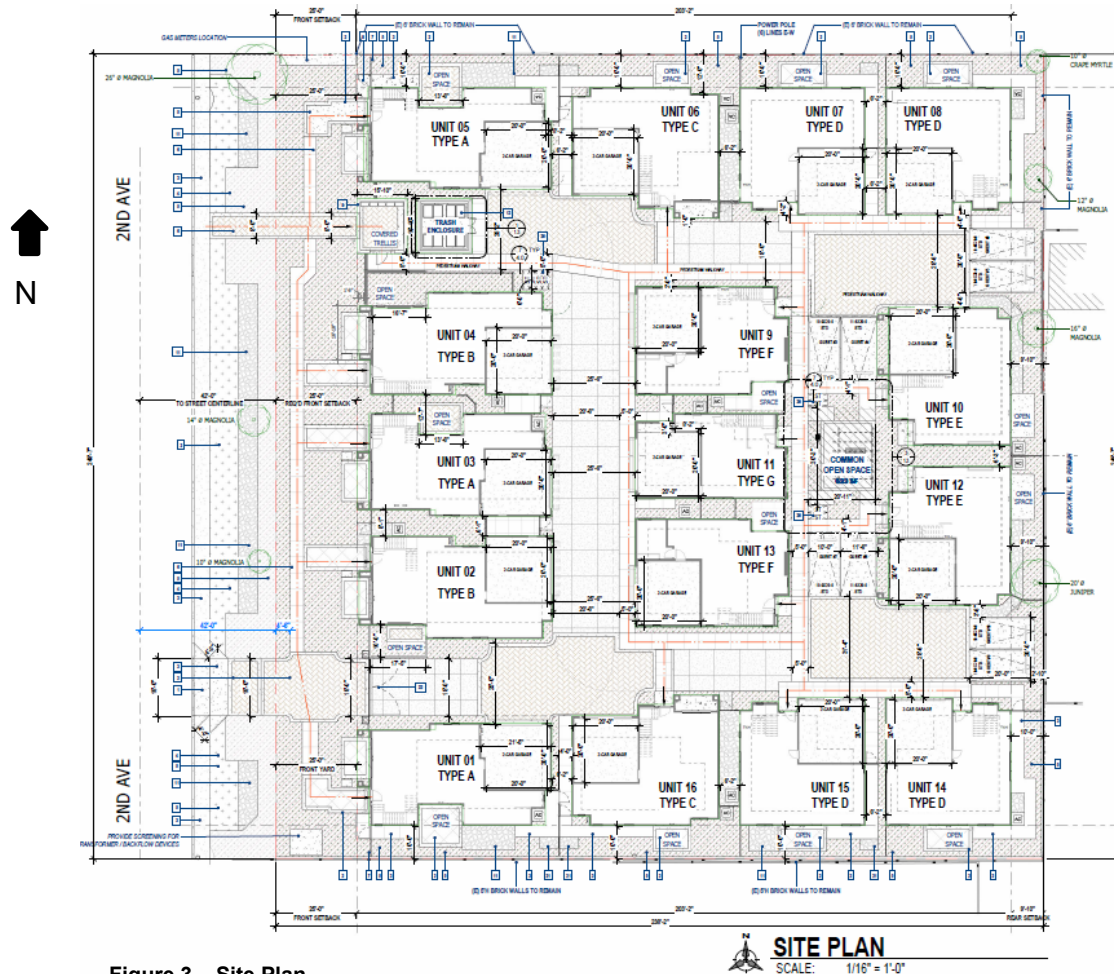

Figure 3 – Site Plan

The proposal also includes the removal of 30 existing unprotected trees and one protected Coast Live Oak tree that is located within the front yard area at 320 S. Second Avenue to accommodate the proposed development. The proposed development will also encroach within the dripline of another protected tree, a Southern Magnolia tree, that is located within the required rear yard walls setback at 320 S. Second Avenue. Additional analysis will be provided later in this staff report under the Analysis section.

ANALYSIS

The project complies with the development standards of the R-2 zone, including, but not limited to setbacks, height, and open space. Also, the proposed project complies with the minimum parking requirements for each of the units, guest parking, and bicycles spaces.

The R-2 zone requires a minimum density of two dwelling units per lot, and a maximum density of one unit per 3,750 square feet of lot area. This calculates a maximum density of 15 units for the combined lot area. However, in order to comply with the State's "No Net Loss" law, at no time may a jurisdiction take action on a permit that will cause a

shortfall of sites in the Regional Housing Needs Assessment (RHNA), therefore the project must have at least 16 units since it currently has that many units.

Concurrent with the subdivision application, the Planning Commission must approve, conditionally approve, or deny the architectural design of the proposed project. The project is designed in a Contemporary architectural style – refer to Attachment No. 4 and Figure 2. There are five units that front onto Second Avenue in order to promote pedestrian areas and define the street frontage. The exterior walls of the building are proposed to be finished with a white stucco with brick veneer and vertical wood cladding which will be used to accent some exterior walls. The roof would consist of grey colored roofing tiles. Many of the elements incorporated in this design, such as the neutral tone stucco with complimentary brick veneer, pitched roof, clean lines, and articulation between the different stories are found on Second Avenue and help the project blend in with developments in the vicinity that have similar features.

The massing and scale of this project will be compatible with the other multi-family developments found within this immediate neighborhood. The Contemporary style of the buildings will provide an elevated and modern look to the immediate neighborhood which is a mix of different architectural styles, heights, and massing. The Contemporary style mixes traditional elements with a modern flare which complements and elevates the streetscape. The layout of the detached units helps to achieve a smaller scale and reduce the physical mass to better blend the project in with the existing surroundings which is made up of other multifamily developments and single-family residences. The front-facing balconies will not be out of character as there are other developments that also feature front-facing balconies on the street, including a project that was recently approved by the Planning Commission. The height of the new development will be compatible with the existing developments on Second Avenue as there are other two-story developments that have building heights at approximately 30'-0" such as the adjacent property next door which features subterranean parking and two stories. Additionally, there will be landscape hedging along the perimeter of the site that would provide a buffer between the subject property and the adjacent multifamily developments and there will be a minimum of 10 feet setback from all the adjacent properties. Therefore, the proposed development and subdivision of condominiums would be consistent with the City's General Plan, Multiple-Family Residential Design Guidelines, the Development Code, the State Subdivision Map Act, and would not violate any requirements of the California Regional Water Quality Control Board.

Tree Removal

The Applicant is requesting to remove one (1) protected Coast Live Oak tree on site. The tree is located in the northwest portion of the property and has a trunk diameter of 16 inches. Due to its species and size, the tree is protected per the City's Protected Tree Ordinance and a health rating of 'B' (Adequate Health but with slight decline). The tree is proposed to be removed because its root would be severely encroached upon during construction of one of the units and there would be limited space for any future canopy growth. In addition, each of the buildings is at the minimum building separation, setbacks,

and open space requirements and to accommodate the tree would result in a bulkier and less high-quality design. As a result, the tree is proposed to be removed as noted in the Arborist Report – refer to Attachment 5 of the Arborist Report.

In this case, there is sufficient justification for the removal of the tree. As a remedial measure, the project will be subject to Condition No. 3, which requires that two (2) replacement trees be planted as part of the project. However, the Applicant is proposing to plant a one (1) 60" box Coast Live Oak, and two additional 36" box Magnolia 'Little Gem' trees as replacement trees along the front yard in order to meet and exceed the required replacement trees, see figure 4 below.

Tree Encroachment

The proposed construction of Unit 10 in the rear of the property will encroach within the protected area of one (1) Southern Magnolia tree. However, no structural excavation will be taking place within the critical root zone. The tree is expected to survive as long as the Applicant adheres to the recommendations in the Arborist Report during demolition and construction and a Certified Arborist will have to be on-site during grading to ensure all the trees are protected – refer to Condition No. 4.

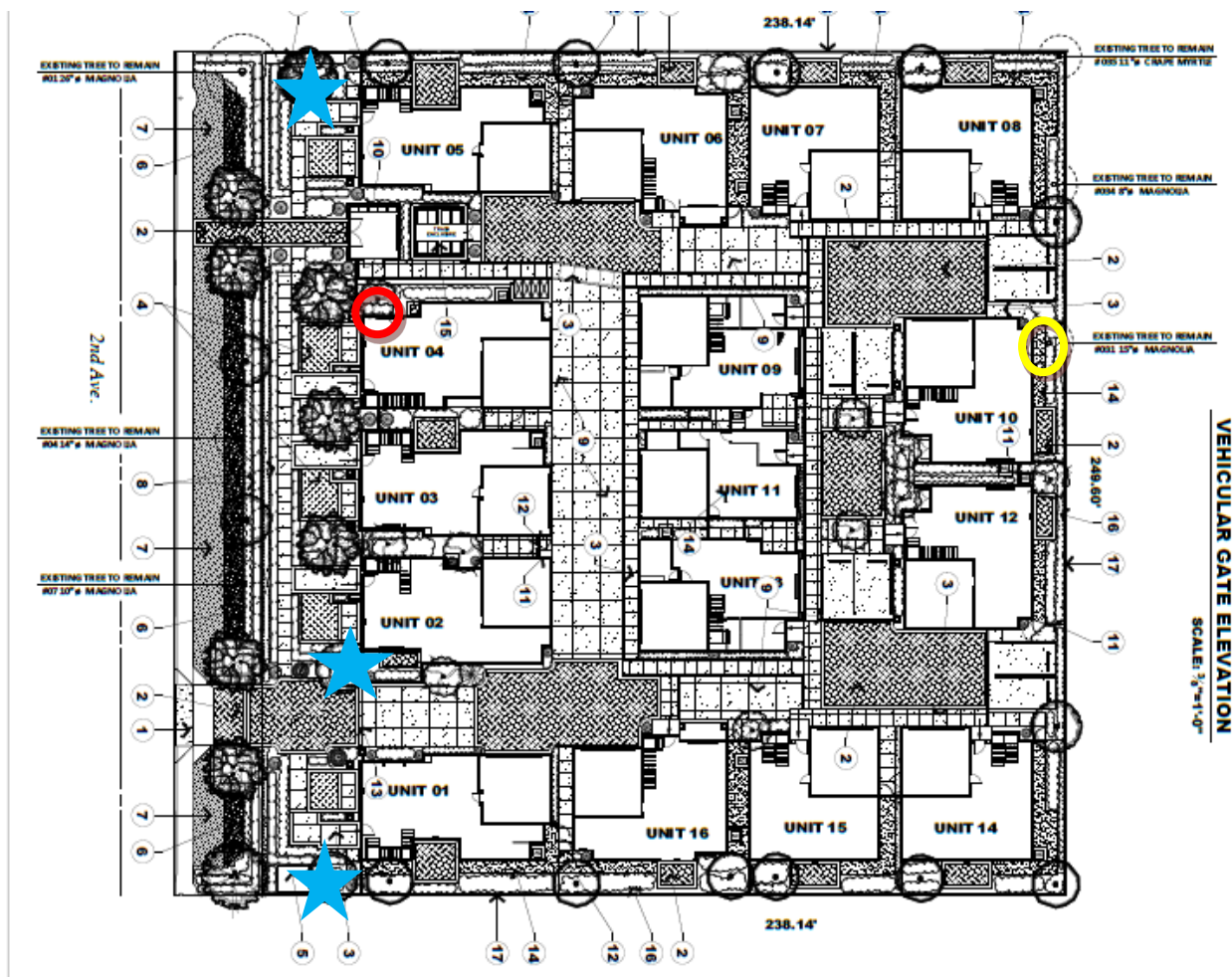

Figure 4 – Circled in Red: Coast Live Oak (#29) to be removed, Circled in Yellow: Southern Magnolia (#31) to remain; Blue Stars are the required replacement trees.

FINDINGS

Tentative Tract Map

The proposal to subdivide the airspace for 16 residential condominium units requires a subdivision through the Tentative tract map process – see Attachment No. 3 for Tentative Tract Map No. TTM 23-05 (84291). The proposed subdivision complies with the subdivision regulations of the Arcadia Municipal Code and the Subdivision Map Act and would not violate any requirements of the California Regional Water Quality Control Board. The following findings are required for approval of a Tentative tract map:

A. The proposed map, subdivision design, and improvements are consistent with the General Plan, any applicable specific plan, and the Subdivisions Division of the Development Code.

Facts in Support of the Finding: The proposed tentative tract map for a 16-unit multi-family residential condominium development and subdivision of the airspace has been reviewed for compliance with the City’s General Plan and Development Code, and the Subdivision Map Act. The Project will exceed the maximum density by providing 16 residential units instead of 15 units to ensure the project complies with Government Code Section 65863 – the No Net Loss Law. The Project will not be detrimental to the General Plan Medium Density Residential Land Use designation and the R-2, Medium Density Multiple Family Residential zoning designation, respectively. These designations are intended to accommodate high density residential units such as condominiums, within the appropriate neighborhoods such as this. There is no specific plan applicable to this project. The proposed tentative tract map complies with the Subdivision Map Act because the proposed 16-unit condominium development complies with the requirements of the Subdivisions Division of the Development Code and all other City requirements to subdivide for condominium purposes.

The Project would not adversely affect the comprehensive General Plan and is consistent with the following General Plan goals and policies:

Land Use and Community Design Element

- Policy LU-1.1: Promote new infill and redevelopment projects that are consistent with the City’s land use and compatible with surrounding existing uses.
- Policy LU-4.1: Require that new multi-family residential development be visually and functionally integrated and consistent in scale, mass, and character with structures in the surrounding neighborhood.
- Policy LU-4.2: Encourage residential development that enhances the visual character, quality, and uniqueness of the City’s neighborhoods and districts.

B. The site is physically suitable for the type and proposed density of development.

Facts in Support of the Finding: The site is physically suitable for this type of development and the consolidation of the four (4) lots into one lot can accommodate the project and comply with all other applicable zoning requirements, including but not limited to parking, setbacks, height, and open space. The site will provide ample amenities for residents and will be compatible with the existing neighborhood. Since the existing site has existed for many years with 16 units without detriment, the site is suitable to replace the existing density of 16 units with 16 units. Therefore, the site is physically suitable for the proposed 16-unit multi-family residential development.

C. The design of the subdivision and the proposed improvements are not likely to cause substantial environmental damage or substantially and avoidably injure fish or wildlife or their habitat.

Facts in Support of the Finding: The project is an infill site within an urbanized area and does not serve as a habitat for endangered or rare species. Therefore, the Project would not cause substantial environmental damage or impact wildlife.

D. The design of the subdivision or type of improvements is not likely to cause serious public health or safety problems.

Facts in Support of the Finding: The project is to subdivide the airspace of 16 units for condominium purposes. The construction would be in compliance with all applicable Building and Fire Codes to ensure public health and safety. While the proposed 16 units exceeds the calculated maximum allowed, the existing site has 16 units, therefore, allowing the same number of units as already exists will not be detrimental and shows the City's existing infrastructure would adequately serve the new development. Therefore, the development would not cause any public health or safety problems.

E. The design of the subdivision or the type of improvements will not conflict with easements acquired by the public at large for access through or use of, property within the proposed subdivision (This finding shall apply only to easements of record or to easements established by judgement of a court of competent jurisdiction and no authority is hereby granted to a legislative body to determine that the public at large has acquired easements for access through or use of property within the proposed subdivision).

Facts in Support of the Finding: There are three existing six-foot wide easements that will remain for utility purposes for this project. The project will not conflict with these easements as no permanent structures will be built over the easements. The 10-foot-wide utility easement that runs through the center of the

property shall be quitclaimed prior to approval of the Final Tract Map. Therefore, the project does not conflict with the existing easements, as acquired by the public at large for access through or use of property within the proposed subdivision.

F. The discharge of sewage from the proposed subdivision into the community sewer system would not result in violation of existing requirements specified by the California Regional Water Quality Control Board.

Facts in Support of the Finding: The Arcadia Public Works Services Department determined that the City's existing infrastructure would adequately serve the new development, and the requirements of the California Regional Water Quality Control Board would be satisfied.

G. The proposed design and site improvements of the subdivision conform to the regulations of the City's Development Code and the regulations of any public agency having jurisdiction by law.

Facts in Support of the Finding: The project is in conformance with all the regulations of the City's Development Code. The project will replace the same number of units that are on the four parcels, therefore there will be no net loss from this new development. There is no other public agency that has jurisdiction over this subject site.

Architectural Design Review

The proposed development is located within the Medium Density Residential (R-2) Zone, which is intended to provide a variety of medium to high density residential developments. The proposed design of the 16-unit condominium project is compatible with existing multi-family developments in the surrounding neighborhood in terms of design, massing, and scale. The proposed Contemporary architectural style would be compatible with other existing multi-family developments along Second Avenue as the neighborhood is eclectic with no dominant architectural style. The architectural elements incorporated in this design, such as neutral toned stucco, tile roofing, and brick veneer, are consistent with developments in the vicinity that have similar features. Additionally, the massing and scale of the new development will not be out of character with developments in the vicinity as many of the existing multi-family developments, despite being two-stories, are around 30' 0" in height. The proposed buildings have articulation on all facades, providing visual interest and reducing massing. The proposed design is therefore consistent with the City's Multi-family Residential Design Guidelines. All City requirements regarding disabled access and facilities, occupancy limits, building safety, health code compliance, emergency equipment, environmental regulation compliance, and parking and site design shall be complied with by the property owner/Applicant to the satisfaction of the Building Official, City Engineer, Deputy Development Services Director, Fire Marshal, and Public Works Services Director, or their respective designees.

ENVIRONMENTAL ASSESSMENT

It has been determined that the project site is less than five (5) acres; the project site has no value as a habitat for endangered, rare or threatened species; the proposed project would not have any significant effects upon the environment, and the site can be adequately served by all the required utilities and public services. Therefore, the project is exempt under Class 32 (In-Fill Development Projects) pursuant to Section 15332 of the State California Environmental Quality Act (CEQA) Guidelines. Refer to Attachment No. 5 for the Preliminary Exemption Assessment.

PUBLIC NOTICE/COMMENTS

A public hearing notice for this item was posted at the City Clerk’s Office, City Council Chambers, at the Arcadia Library, and on the City’s website on February 29, 2024. It was also mailed to the property owners located within 300 feet of the subject property. As of March 12, 2024, no comments were received regarding this project. The existing tenants were also notified of the project on February 2, 2024.

RECOMMENDATION

It is recommended that the Planning Commission approve Multiple Family Architectural Design Review No. MFADR 23-03, Tentative Tract Map No. TTM 23-05 (84291), Healthy Tree Removal No. TRH 23-04, and Protected Tree Encroachment No. TRE 23-10, subject to the following conditions, find that the project is Categorically Exempt from the California Environmental Quality Act (CEQA), and adopt Resolution No. 2142, subject to the following conditions of approval:

1. The project shall be developed and maintained by the Applicant/Property Owner in a manner that is consistent with the plans submitted and conditionally approved for Multiple Family Architectural Design Review No. MFADR 23-03, Tentative Tract Map No. TTM 23-05 (84291), Healthy Tree Removal No. TRH 23-04, and Protected Tree Encroachment No. TRE 23-10, subject to the approval of the Deputy Development Services Director, or designee.
2. Any required mechanical equipment, such as backflow devices, visible from the public right-of-way shall be screened from public view. Screening may include landscaping, solid walls or other methods deemed appropriate for the development. The placement and height of said screening shall be subject to review and approval by the Deputy Development Services Director, or designee.
3. The Applicant/Property Owner shall plant a 60” box Coast Live Oak tree and two 36-inch box Magnolia “Little Gem” trees within the front yard area as part of the replacement trees for the removal of the healthy protected tree. These trees must be shown on the final landscape plan. The Applicant/Property Owner shall also comply with all the measures listed in the Arborist Report, dated December 9, 2023. During construction, a Certified Arborist shall be on-site to monitor and ensure

proper placement of the new replacement trees as well as survival of the existing protected Southern Magnolia tree. A follow-up report shall be submitted to the City prior to issuance of a Certificate of Occupancy.

4. The Applicant/Property Owner shall comply with all the measures listed in the Arborist Report, dated December 9, 2023. If the Certified Arborist determines that the tree may not survive at the time the follow-up report is prepared, then the Applicant shall plant a new 36-inch box tree on the subject site prior to issuance of a Certificate of Occupancy. The location and type shall be approved by the Deputy Development Services Director or designee.
5. The project shall comply with the latest adopted edition of the following codes as applicable:
 - a) California Building Code
 - b) California Electrical Code
 - c) California Mechanical Code
 - d) California Plumbing Code
 - e) California Energy Code
 - f) California Fire Code
 - g) California Green Building Standards Code
 - h) California Existing Building Code
 - i) Arcadia Municipal Code
6. The project shall comply with Chapter 35A Multiple Family Construction Standards as amended in the Arcadia Municipal Code Section 8130.20.
7. All utility conductors, cables, conduits and wiring supplying electrical, cable and telephone service to a multiple family building shall be installed underground except risers which are adjacent to and attached to a building.
8. A grading plan shall be prepared by a registered civil engineer and approved by the City prior to issuance of a building permit. The grading plans shall indicate all on- and off-site improvements and shall indicate complete drainage paths of all drainage water run-off.
9. A demolition permit shall be obtained from Building Services prior to the removal and/or demolition of the structures on site.
10. Prior to approval of the Tract Map, the Applicant/Property Owner shall:
 - a. Remove existing driveway approaches and construct new driveway approach per the City's standards.
 - b. Remove and replace new sidewalk providing adequate path of travel in compliance with Americans with Disabilities Act (ADA). Ensure locations around obstructions provide necessary clearances.

- c. Remove and replace curb and gutter with 2' asphalt slot cut from property line to property line along the property frontage of Second Avenue.
 - d. The 10-foot easement that is owned by Southern California Edison shall be quitclaimed and a copy of the recordation shall be submitted to the City prior to filing the final tract map.
11. The Applicant/Property Owner shall submit a Low Impact Development (LID) plan for this project, and it shall comply with the Los Angeles County Department of Public Works 2014 LID standard Manual and show the selected measures on the grading plan. These selected measures include, but are not limited to using infiltration trenches, bio-retention planter boxes, roof drains connected to a landscaped area, pervious concrete/paver, etc.
12. Prior to receiving a Certificate of Occupancy, the Applicant/Property Owner shall repair any damages caused by the development to the asphalt street frontages from property line to property line including but not limited to trench cuts and construction traffic, as determined by the City Engineer.
13. There is a 12-inch ductile iron water main with 80 psi static pressure that the development shall connect to on Second Avenue. for domestic water and/or fire services. The Applicant/Property Owner shall provide calculations to the Public Works Services Department to determine the total combined maximum domestic and fire demand and verify the water service size required prior to issuance of a Building Permit.
14. The Applicant/Property Owner shall install a common master water meter for the residential multi-family development. The water meter for each unit can be used to supply both domestic water services and fire services. The Applicant/Property Owner shall separate the fire service from domestic water service with an approved back flow device.
15. A separate water service and meter shall be required for common area landscape irrigation. A reduced pressure backflow device shall be installed.
16. Fire protection requirements shall be as stipulated by the Arcadia Fire Department and shall be conformed to Arcadia Standard Plan. A separate fire service with Double Check Detector Assembly (DCDA) shall be installed for fire service if required.
17. A Water Meter Permit Application shall be submitted to the Public Works Services Department prior to issuance of a building permit for the new development.
18. New water service installations shall be by the Applicant/Property Owner. Installation shall be according to the specifications of the Public Works Services Department,

Engineering Section. Abandonment of existing water services, if necessary, shall be by the Applicant/Property Owner, according to Public Works Services Department.

19. An 8" Vitrified Clay Pipe (VCP) sewer line is available on Second Avenue to provide sanitary sewer service for the project. The Applicant/Property Owner shall utilize the existing sewer lateral, if possible. If there are any changes to the existing sewer lateral, the Applicant/Property Owner shall obtain approval from the Los Angeles County Sanitation District to connect to the existing sewer main prior to commencing work any work, and an encroachment permit from City of Arcadia.
20. If any drainage fixture elevation is lower than the elevation of next upstream manhole cover, an approved type of backwater valve is required to be installed on the lateral at the right-of-way and it shall be reviewed and approved by the Public Works Department prior to issuance of a building permit.
21. The Applicant/Property Owner shall file a Notice of Intent (NOI) with the State Water Resources Control Board for a General Construction NPDES Permit and pay applicable fees to the State Water Resources Control Board.
22. The Applicant/Property Owner shall prepare a Storm Water Pollution Prevention Plan (SWPPP) as part of the General Construction Permit requirements prior to issuance of a building permit.
23. All structures shall be provided with an automatic fire sprinkler system per the City of Arcadia Fire Department Single & Multi-Family Dwelling Sprinkler Standard.
24. A Knox box shall be provided adjacent to the pedestrian and vehicle gates so that the pedestrian and vehicle entry gate shall be openable without a special key for the City of Arcadia Fire Department.
25. The Applicant/Property Owner shall comply with all City requirements regarding building safety, fire prevention, detection, suppression, emergency access, public right-of-way improvements, parking, water supply and water facilities, sewer facilities, trash reduction and recycling requirements, and National Pollutant Discharge Elimination System (NPDES) measures to the satisfaction of the Building Official, Fire Marshal, Public Works Services Director, and Deputy Development Services Director, or their respective designees. Compliance with these requirements is to be determined by having fully detailed construction plans submitted for plan check review and approval by the foregoing City officials and employees.
26. To the maximum extent permitted by law, Applicant must defend, indemnify, and hold the City, any departments, agencies, divisions, boards, and/or commissions of the City, and its elected officials, officers, contractors serving as City officials, agents, employees, and attorneys of the City ("Indemnitees") harmless from liability for

damages and/or claims, actions, or proceedings for damages for personal injuries, including death, and claims for property damage, and with respect to all other actions and liabilities for damages caused or alleged to have been caused by reason of the Applicant's activities in connection with MFADR 23-03, TTM 23-05 (84291), TRH 23-04, TRE 23-10 ("Project") on the Project site, and which may arise from the direct or indirect operations of the Applicant or those of the Applicant's contractors, agents, tenants, employees or any other persons acting on Applicant's behalf, which relate to the development and/or construction of the Project. This indemnity provision applies to all damages and claims, actions, or proceedings for damages, as described above, regardless of whether the City prepared, supplied, or approved the plans, specifications, or other documents for the Project.

In the event of any legal action challenging the validity, applicability, or interpretation of any provision of this approval, or any other supporting document relating to the Project, the City will notify the Applicant of the claim, action, or proceedings and will cooperate in the defense of the matter. The Applicant must indemnify, defend and hold harmless the Indemnitees, and each of them, with respect to all liability, costs and expenses incurred by, and/or awarded against, the City or any of the Indemnitees in relation to such action. Within 15 days' notice from the City of any such action, the Applicant shall provide to the City a cash deposit to cover legal fees, costs, and expenses incurred by City in connection with defense of any legal action in an initial amount to be reasonably determined by the City Attorney. The City may draw funds from the deposit for such fees, costs, and expenses. Within 5 business days of each and every notice from the City that the deposit has fallen below the initial amount, Applicant/Property Owner shall replenish the deposit each and every time in order for City's legal team to continue working on the matter. The City shall only refund to the Applicant/Property Owner any unexpended funds from the deposit within 30 days of: (i) a final, non-appealable decision by a court of competent jurisdiction resolving the legal action; or (ii) full and complete settlement of legal action. The City shall have the right to select legal counsel of its choice. The parties hereby agree to cooperate in defending such action. The City will not voluntarily assist in any such third-party challenge(s). In consideration for approval of the Project, this condition shall remain in effect if the entitlement(s) related to this Project is rescinded or revoked, at the request of the Applicant or not.

27. Approval of for Multiple Family Architectural Design Review No. MFADR 23-03, Tentative Tract Map No. TTM 23-05 (84291), Healthy Tree Removal No. TRH 23-04, and Protected Tree Encroachment No. TRE 23-10 shall not be in effect unless the Property Owner and Applicant have executed and filed the Acceptance Form with the City on or before 30 calendar days after the Planning Commission has adopted the Resolution. The executed Acceptance Form submitted to the Development Services Department is to indicate awareness and acceptance of the conditions of approval.

PLANNING COMMISSION ACTION

Approval

If the Planning Commission intends to approve this project, the Commission should move to approve Multiple Family Architectural Design Review No. MFADR 23-03, Tentative Tract Map No. TTM 23-05 (84291), Healthy Tree Removal No. TRH 23-04, and Protected Tree Encroachment No. TRE 23-10, and Protected Diseased Tree Removal Permit No. TRD 23-08 and state that the proposal satisfies the requisite findings, and adopt the attached Resolution No. 2142 that incorporates the requisite environmental and subdivision findings, and the conditions of approval as presented in this staff report, or as modified by the Commission.

Denial

If the Planning Commission is to deny this project, the Commission should state the specific findings that the proposal does not satisfy based on the evidence presented with specific reasons for denial, and move to deny Multiple Family Architectural Design Review No. MFADR 23-03, Tentative Tract Map No. TTM 23-05 (84291), Healthy Tree Removal No. TRH 23-04, and Protected Tree Encroachment No. TRE 23-10 direct staff to prepare a resolution for adoption at the next meeting that incorporates the Commission's decision and specific findings.

If any Planning Commissioner, or other interested party has any questions or comments regarding this matter prior to the March 12, 2024, Planning Commission Meeting, please contact Assistant Planner, Alison MacCarley, at (626) 547-5447, or amaccarley@ArcadiaCA.gov.

Approved:



Lisa L. Flores
Deputy Development Services Director

- Attachment No. 1: Resolution No. 2142
- Attachment No. 2: Aerial Photo with Zoning Information and Photos of the Subject Property and Vicinity
- Attachment No. 3: Tentative Tract Map No. TTM 23-05 (84291)
- Attachment No. 4: Architectural Plans
- Attachment No. 5: Arborist Reported Dated December 9, 2023
- Attachment No. 6: Preliminary Exemption Assessment

RESOLUTION NO. 2142

A RESOLUTION OF THE PLANNING COMMISSION OF THE CITY OF ARCADIA, CALIFORNIA, APPROVING MULTIPLE FAMILY ARCHITECTURAL DESIGN REVIEW NO. MFADR 23-03, TENTATIVE TRACT MAP NO. TTM 23-05 (84291), HEALTHY TREE REMOVAL NO. TRH 23-04, AND PROTECTED TREE ENCROACHMENT NO. TRE 23-10 FOR A 16-UNIT, CONTEMPORARY STYLE, MULTI-FAMILY RESIDENTIAL CONDOMINIUM DEVELOPMENT AT 314-326 S. SECOND AVENUE

WHEREAS, on September 1, 2022, applications for Multiple Family Architectural Design Review No. MFADR 23-01, Tentative Tract Map No. TTM 23-02 (83831), and Healthy Tree Removal Permit No. TRH 23-14 were filed by Philip Chan on behalf of the property owner, Smart Property LA II LLC, a 16 unit, three-story, contemporary style multi-family residential condominium development, a tentative tract map subdivision, and the removal of a protected Coast Live Oak Tree and encroachment into the dripline of one protected tree at 314-326 S. Second Avenue (collectively, "Project"); and

WHEREAS, on January 20, 2024, Planning Services completed an environmental assessment for the Project in accordance with the California Environmental Quality Act ("CEQA"), and recommends that the Planning Commission determine the Project is exempt under CEQA per Section 15332 of the CEQA Guidelines because the Project is considered an in-fill development project; and

WHEREAS, on March 12, 2024, a duly-noticed public hearing was held before the Planning Commission on said Project, at which time all interested persons were given full opportunity to be heard and to present evidence.

NOW, THEREFORE, THE PLANNING COMMISSION OF THE CITY OF ARCADIA HEREBY RESOLVES AS FOLLOWS:

SECTION 1. The factual data submitted by the Community Development Division in the staff report dated March 12, 2024, are true and correct.

SECTION 2. This Commission finds, based upon the entire record:

a. The proposed map, subdivision design, and improvements are consistent with the General Plan, any applicable specific plan, and the Subdivisions Division of the Development Code.

FACT: The proposed tentative tract map for a 16-unit multi-family residential condominium development and subdivision of the airspace has been reviewed for compliance with the City's General Plan and Development Code, and the Subdivision Map Act. The Project will exceed the maximum density by providing 16 residential units instead of 15 units to ensure the project complies with Government Code Section 65863 – the No Net Loss Law. The Project will not be detrimental to the General Plan Medium Density Residential Land Use designation and the R-2, Medium Density Multiple Family Residential zoning designation, respectively. These designations are intended to accommodate high density residential units such as condominiums, within the appropriate neighborhoods such as this. There is no specific plan applicable to this project.

The proposed tentative tract map complies with the Subdivision Map Act because the proposed 16-unit condominium development complies with the requirements of the Subdivisions Division of the Development Code and all other City requirements to subdivide for condominium purposes.

The Project would not adversely affect the comprehensive General Plan and is consistent with the following General Plan goals and policies:

Land Use and Community Design Element

- Policy LU-1.1: Promote new infill and redevelopment projects that are consistent with the City's land use and compatible with surrounding existing uses.
- Policy LU-4.1: Require that new multi-family residential development be visually and functionally integrated and consistent in scale, mass, and character with structures in the surrounding neighborhood.
- Policy LU-4.2: Encourage residential development that enhances the visual character, quality, and uniqueness of the City's neighborhoods and districts.

b. The site is physically suitable for the type and proposed density of development.

FACT: The site is physically suitable for this type of development and the consolidation of the four (4) lots into one lot can accommodate the Project and comply with all other applicable zoning requirements, including but not limited to parking, setbacks, height, and open space. The site will provide ample amenities for residents and will be compatible with the existing neighborhood. Since the existing site has existed for many years with 16 units without detriment, the site is suitable to replace the existing density of 16 units with 16 units. Therefore, the site is physically suitable for the proposed 16-unit multi-family residential development.

c. The design of the subdivision and the proposed improvements are not likely to cause substantial environmental damage or substantially and avoidably injure fish or wildlife or their habitat.

FACT: The Project is an infill site within an urbanized area and does not serve as a habitat for endangered or rare species. Therefore, the Project would not cause substantial environmental damage or impact wildlife.

d. The design of the subdivision or type of improvements is not likely to cause serious public health or safety problems.

FACT: The Project is to subdivide the airspace of 16 units for condominium purposes. The construction would be in compliance with all applicable Building and Fire Codes to ensure public health and safety. While the proposed 16 units exceeds the calculated maximum allowed, the existing site has 16 units, therefore, allowing the same number of units as already exists will not be detrimental and shows the City's existing infrastructure would adequately serve the new development. Therefore, the development would not cause any public health or safety problems.

e. The design of the subdivision or the type of improvements will not conflict with easements acquired by the public at large for access through or use of, property within the proposed subdivision (This finding shall apply only to easements of record or to easements established by judgement of a court of competent jurisdiction and no authority is hereby granted to the review authority to determine that the public at large has acquired easements for access through or use of property within the proposed subdivision):

FACT: There are three existing six-foot wide easements that will remain for utility purposes for this Project. The Project will not conflict with these easements as no permanent structures will be built over the easements. The 10-foot-wide utility easement that runs through the center of the property shall be quitclaimed prior to approval of the Final Tract Map. Therefore, the Project does not conflict with the existing easements, as

acquired by the public at large for access through or use of property within the proposed subdivision.

f. The discharge of sewage from the proposed subdivision into the community sewer system will not result in violation of existing requirements specified by the California Regional Water Quality Control Board.

FACT: The Arcadia Public Works Services Department determined that the City's existing infrastructure would adequately serve the new development, and the requirements of the California Regional Water Quality Control Board would be satisfied.

g. The proposed design and site improvements of the subdivision conform to the regulations of the City's Development Code and the regulations of any public agency having jurisdiction by law.

FACT: The Project is in conformance with all the regulations of the City's Development Code. The Project will replace the same number of units that are on the four parcels, therefore there will be no net loss from this new development. There is no other public agency that has jurisdiction over this subject site.

h. The proposal is consistent with the City's Multifamily Residential Design Guidelines:

FACT: The proposed development is located within the Medium Density Residential (R-2) Zone, which is intended to provide a variety of medium to high density residential developments. The proposed design of the 16-unit condominium project is compatible with existing multi-family developments in the surrounding neighborhood in terms of design, massing, and scale. The proposed Contemporary architectural style would be compatible with other existing multi-family developments along Second Avenue

as the neighborhood is eclectic with no dominant architectural style. The architectural elements incorporated in this design, such as neutral toned stucco, tile roofing, and brick veneer, are consistent with developments in the vicinity that have similar features. Additionally, the massing and scale of the new development will not be out of character with developments in the vicinity as many of the existing multi-family developments, despite being two-stories, are around 30' 0" in height. The proposed buildings have articulation on all facades, providing visual interest and reducing massing. The proposed design is therefore consistent with the City's Multi-family Residential Design Guidelines.

i. Removal of a Healthy Protected Tree and Encroachment into a Protected Tree

FACT: The removal of the protected Coast Live Oak tree is necessary since it will not survive due to the proposed grading and excavation for one of the units and that the construction will severely damage the roots and there would be limited space for any future canopy growth. The proposed encroachment within the dripline of the protected tree (Southern Magnolia tree) is also necessary for the construction of one of the units in the rear of the property, however, the potential impacts of the construction of the units and proposed improvements will not harm the health of the tree, and its long-term health since the tree will not be within the area of structural excavation of one of the units and the Applicant shall be required to follow all protection measures within the Arborist report. Therefore, the removal of a healthy protected tree and encroachment into the dripline of a protected tree are warranted to accommodate the proposed development.

SECTION 3. Pursuant to the provisions of the California Environmental Quality Act ("CEQA"), this Project is a Class 32 Categorical Exemption as an infill-development project per Section 15332 of the CEQA Guidelines.

SECTION 4. For the foregoing reasons the Planning Commission determines that the Project is Categorically Exempt under the California Environmental Quality Act (“CEQA”) Section 15332, Class 32, and approves Multiple Family Architectural Design Review No. MFADR 23-03, Tentative Tract Map No. TTM 23-05 (84291), Healthy Tree Removal No. TRH 23-04, and Protected Tree Encroachment No. TRE 23-10 for a 16-unit, contemporary style, multi-family residential condominium development and the removal of one protected tree and the encroachment into the protected area of one protected tree at 314-326 S. Second Avenue, subject to the conditions of approval attached hereto.

SECTION 5. The Secretary shall certify to the adoption of this Resolution.

[SIGNATURES ON THE NEXT PAGE]

Passed, approved and adopted this 12th day of March, 2024.

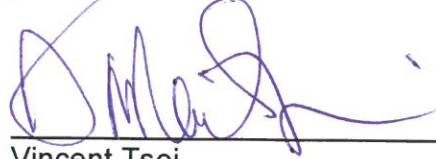

Vincent Tsoi
Chair, Planning Commission

ATTEST:

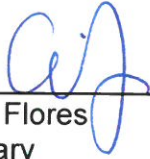

Lisa L. Flores
Secretary

APPROVED AS TO FORM:

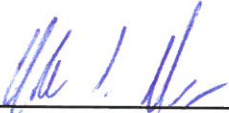

Michael J. Maurer
City Attorney

STATE OF CALIFORNIA)
COUNTY OF LOS ANGELES) §:
CITY OF ARCADIA)

I, Lisa Flores, Secretary of the Planning Commission of the City of Arcadia, hereby certify that the foregoing Resolution No. 2142 was passed and adopted by the Planning Commission of the City of Arcadia, signed by the Chair, and attested to by the Secretary at a regular meeting of said Planning Commission held on the 12th day of March 2024, and that said Resolution was adopted by the following vote, to wit:

AYES: Chair Tsoi, Commissioners Hui, Tallerico

NOES: Vice Chair Wilander and Commissioner Arvizu

ABSENT: None



Lisa L. Flores
Secretary of the Planning Commission

RESOLUTION NO. 2142

Conditions of Approval

1. The project shall be developed and maintained by the Applicant/Property Owner in a manner that is consistent with the plans submitted and conditionally approved for Multiple Family Architectural Design Review No. MFADR 23-03, Tentative Tract Map No. TTM 23-05 (84291), Healthy Tree Removal No. TRH 23-04, and Protected Tree Encroachment No. TRE 23-10, subject to the approval of the Deputy Development Services Director, or designee.
2. Any required mechanical equipment, such as backflow devices, visible from the public right-of-way shall be screened from public view. Screening may include landscaping, solid walls or other methods deemed appropriate for the development. The placement and height of said screening shall be subject to review and approval by the Deputy Development Services Director, or designee.
3. The Applicant/Property Owner shall plant a 60-inch box Coast Live Oak tree and two 36-inch box Magnolia "Little Gem" trees within the front yard area as part of the replacement trees for the removal of the healthy protected tree. These trees must be shown on the final landscape plan. The Applicant/Property Owner shall also comply with all the measures listed in the Arborist Report, dated December 9, 2023. During construction, a Certified Arborist shall be on-site to monitor and ensure proper placement of the new replacement trees as well as survival of the existing protected Southern Magnolia tree. A follow-up report shall be submitted to the City prior to issuance of a Certificate of Occupancy.
4. The Applicant/Property Owner shall comply with all the measures listed in the Arborist Report, dated December 9, 2023. If the Certified Arborist determines that the tree may not survive at the time the follow-up report is prepared, then the Applicant shall plant a new 36-inch box tree on the subject site prior to issuance of a Certificate of Occupancy. The location and type shall be approved by the Deputy Development Services Director or designee.
5. The project shall comply with the latest adopted edition of the following codes as applicable:
 - a) California Building Code
 - b) California Electrical Code
 - c) California Mechanical Code
 - d) California Plumbing Code
 - e) California Energy Code
 - f) California Fire Code
 - g) California Green Building Standards Code
 - h) California Existing Building Code
 - i) Arcadia Municipal Code

6. The project shall comply with Chapter 35A Multiple Family Construction Standards as amended in the Arcadia Municipal Code Section 8130.20.
7. All utility conductors, cables, conduits and wiring supplying electrical, cable and telephone service to a multiple family building shall be installed underground except risers which are adjacent to and attached to a building.
8. A grading plan shall be prepared by a registered civil engineer and approved by the City prior to issuance of a building permit. The grading plans shall indicate all on- and off-site improvements and shall indicate complete drainage paths of all drainage water run-off.
9. A demolition permit shall be obtained from Building Services prior to the removal and/or demolition of the structures on site.
10. Prior to approval of the Tract Map, the Applicant/Property Owner shall:
 - a. Remove existing driveway approaches and construct new driveway approach per the City's standards.
 - b. Remove and replace new sidewalk providing adequate path of travel in compliance with Americans with Disabilities Act (ADA). Ensure locations around obstructions provide necessary clearances.
 - c. Remove and replace curb and gutter with 2' asphalt slot cut from property line to property line along the property frontage of Second Avenue.
 - d. The 10-foot easement that is owned by Southern California Edison shall be quitclaimed and a copy of the recordation shall be submitted to the City prior to filing the final tract map.
11. The Applicant/Property Owner shall submit a Low Impact Development (LID) plan for this project, and it shall comply with the Los Angeles County Department of Public Works 2014 LID standard Manual and show the selected measures on the grading plan. These selected measures include, but are not limited to using infiltration trenches, bio-retention planter boxes, roof drains connected to a landscaped area, pervious concrete/paver, etc.
12. Prior to receiving a Certificate of Occupancy, the Applicant/Property Owner shall repair any damages caused by the development to the asphalt street frontages from property line to property line including but not limited to trench cuts and construction traffic, as determined by the City Engineer.
13. There is a 12-inch ductile iron water main with 80 psi static pressure that the development shall connect to on Second Avenue. for domestic water and/or fire services. The Applicant/Property Owner shall provide calculations to the Public Works Services Department to determine the total combined maximum domestic and fire demand and verify the water service size required prior to issuance of a Building Permit.

14. The Applicant/Property Owner shall install a common master water meter for the residential multi-family development. The water meter for each unit can be used to supply both domestic water services and fire services. The Applicant/Property Owner shall separate the fire service from domestic water service with an approved back flow device.
15. A separate water service and meter shall be required for common area landscape irrigation. A reduced pressure backflow device shall be installed.
16. Fire protection requirements shall be as stipulated by the Arcadia Fire Department and shall be conformed to Arcadia Standard Plan. A separate fire service with Double Check Detector Assembly (DCDA) shall be installed for fire service if required.
17. A Water Meter Permit Application shall be submitted to the Public Works Services Department prior to issuance of a building permit for the new development.
18. New water service installations shall be by the Applicant/Property Owner. Installation shall be according to the specifications of the Public Works Services Department, Engineering Section. Abandonment of existing water services, if necessary, shall be by the Applicant/Property Owner, according to Public Works Services Department.
19. An 8" Vitrified Clay Pipe (VCP) sewer line is available on Second Avenue to provide sanitary sewer service for the project. The Applicant/Property Owner shall utilize the existing sewer lateral, if possible. If there are any changes to the existing sewer lateral, the Applicant/Property Owner shall obtain approval from the Los Angeles County Sanitation District to connect to the existing sewer main prior to commencing work any work, and an encroachment permit from City of Arcadia.
20. If any drainage fixture elevation is lower than the elevation of next upstream manhole cover, an approved type of backwater valve is required to be installed on the lateral at the right-of-way and it shall be reviewed and approved by the Public Works Department prior to issuance of a building permit.
21. The Applicant/Property Owner shall file a Notice of Intent (NOI) with the State Water Resources Control Board for a General Construction NPDES Permit and pay applicable fees to the State Water Resources Control Board.
22. The Applicant/Property Owner shall prepare a Storm Water Pollution Prevention Plan (SWPPP) as part of the General Construction Permit requirements prior to issuance of a building permit.
23. All structures shall be provided with an automatic fire sprinkler system per the City of Arcadia Fire Department Single & Multi-Family Dwelling Sprinkler Standard.

24. A Knox box shall be provided adjacent to the pedestrian and vehicle gates so that the pedestrian and vehicle entry gate shall be openable without a special key for the City of Arcadia Fire Department.
25. The Applicant/Property Owner shall comply with all City requirements regarding building safety, fire prevention, detection, suppression, emergency access, public right-of-way improvements, parking, water supply and water facilities, sewer facilities, trash reduction and recycling requirements, and National Pollutant Discharge Elimination System (NPDES) measures to the satisfaction of the Building Official, Fire Marshal, Public Works Services Director, and Deputy Development Services Director, or their respective designees. Compliance with these requirements is to be determined by having fully detailed construction plans submitted for plan check review and approval by the foregoing City officials and employees.
26. To the maximum extent permitted by law, Applicant must defend, indemnify, and hold the City, any departments, agencies, divisions, boards, and/or commissions of the City, and its elected officials, officers, contractors serving as City officials, agents, employees, and attorneys of the City ("Indemnitees") harmless from liability for damages and/or claims, actions, or proceedings for damages for personal injuries, including death, and claims for property damage, and with respect to all other actions and liabilities for damages caused or alleged to have been caused by reason of the Applicant's activities in connection with MFADR 23-03, TTM 23-05 (84291), TRH 23-04, TRE 23-10 ("Project") on the Project site, and which may arise from the direct or indirect operations of the Applicant or those of the Applicant's contractors, agents, tenants, employees or any other persons acting on Applicant's behalf, which relate to the development and/or construction of the Project. This indemnity provision applies to all damages and claims, actions, or proceedings for damages, as described above, regardless of whether the City prepared, supplied, or approved the plans, specifications, or other documents for the Project.

In the event of any legal action challenging the validity, applicability, or interpretation of any provision of this approval, or any other supporting document relating to the Project, the City will notify the Applicant of the claim, action, or proceedings and will cooperate in the defense of the matter. The Applicant must indemnify, defend and hold harmless the Indemnitees, and each of them, with respect to all liability, costs and expenses incurred by, and/or awarded against, the City or any of the Indemnitees in relation to such action. Within 15 days' notice from the City of any such action, the Applicant shall provide to the City a cash deposit to cover legal fees, costs, and expenses incurred by City in connection with defense of any legal action in an initial amount to be reasonably determined by the City Attorney. The City may draw funds from the deposit for such fees, costs, and expenses. Within 5 business days of each and every notice from the City that the deposit has fallen below the initial amount, Applicant/Property Owner shall replenish the deposit each and every time in order for City's legal team to continue working on the matter. The City shall only refund to the Applicant/Property Owner any unexpended funds from the deposit

within 30 days of: (i) a final, non-appealable decision by a court of competent jurisdiction resolving the legal action; or (ii) full and complete settlement of legal action. The City shall have the right to select legal counsel of its choice. The parties hereby agree to cooperate in defending such action. The City will not voluntarily assist in any such third-party challenge(s). In consideration for approval of the Project, this condition shall remain in effect if the entitlement(s) related to this Project is rescinded or revoked, at the request of the Applicant or not.

27. Approval of for Multiple Family Architectural Design Review No. MFADR 23-03, Tentative Tract Map No. TTM 23-05 (84291), Healthy Tree Removal No. TRH 23-04, and Protected Tree Encroachment No. TRE 23-10 shall not be in effect unless the Property Owner and Applicant have executed and filed the Acceptance Form with the City on or before 30 calendar days after the Planning Commission has adopted the Resolution. The executed Acceptance Form submitted to the Development Services Department is to indicate awareness and acceptance of the conditions of approval.

Attachment No. 3

March 12, 2024 Planning Commission
Approved Minutes



**ARCADIA PLANNING COMMISSION
REGULAR MEETING MINUTES
TUESDAY, MARCH 12, 2024**

CALL TO ORDER Chair Tsoi called the meeting to order at 7:00 p.m.

ROLL CALL

PRESENT: Chair Tsoi, Vice Chair Wilander, Arvizu, Hui (arrived at 7:19 p.m.), and Tallerico

ABSENT: None

SUPPLEMENTAL INFORMATION FROM STAFF REGARDING AGENDA ITEMS

There were no items to report.

PUBLIC COMMENTS (5 minute time limit per person)

There were none.

PUBLIC HEARING

1. **Resolution No. 2142**– Approving Multiple Family Architectural Design Review No. MFADR 23-03, Tentative Tract Map No. TTM 23-05 (84291), Healthy Tree Removal No. TRH 23-04, and Protected Tree Encroachment No. TRE 23-10 for 16-unit, Contemporary style, multi-family residential condominium development at 314-326 S. Second Avenue

CEQA: Exempt

Recommendation: Adopt

Applicant: Philip Chan

MOTION - PUBLIC HEARING

Chair Tsoi introduced the item and Assistant Planner, Alison MacCarley presented the staff report.

Vice Chair Wilander asked if one driveway was enough for 16 units. Ms. MacCarley said the Engineering Division had no comments or concerns about the one driveway.

Commissioner Arvizu asked about the square footage of the proposed units.

Deputy Development Services Director Lisa Flores confirmed the units' range in size between 2,300 and 3,200 square feet, and although the maximum density for this project site is 15 units, they are proposing 16 units so there is no net loss.

Commissioner Arvizu asked about the varying layouts of the proposed units and if there are other three-story buildings within a 500 ft radius.

Ms. MacCarley stated that there is one building in the neighborhood that is two stories with a semi-subterranean parking structure that is close to that height if measured from the garage grade.

Any writings or documents provided to a majority of the Planning Commission regarding any item on this agenda will be made available for public inspection in the City's Planning Services Office located at 240 W. Huntington Drive, Arcadia, California, during normal business hours.

Commissioner Arvizu asked why the proposed development does not have parking below grade like those other developments.

Ms. Flores stated semi- subterranean parking is no longer permitted by Code.

Ms. Flores added that the third floor is stepped back approximately fifteen feet from the bottom two floors to help reduce the massing.

Commissioner Arvizu asked if there were other developments in the area that are 30 feet or higher.

Ms. MacCarley said there is a building north of the subject size that is about 30 feet in height.

Commissioner Tallerico asked if the developers meet all the City's standards.

Ms. Flores and Ms. MacCarley confirmed that the proposed development meets all standards.

Chair Tsoi asked where the replacement tree will be planted.

Ms. MacCarley confirmed that the replacement tree will be planted on the northern edge of the property.

The public hearing was opened.

The Applicant, Philip Chan, introduced himself as the Architect of the project and answered the Commissioner's questions.

Mr. Chan answered Commissioner Arvizu's questions about mass and scale and explained the elements that they had incorporated into the design that helps reduce the overall mass and scale.

Mr. Chan distributed a study demonstrating the aerial view of the project and the surrounding neighborhood.

Commissioner Tallerico asked why the units have 5.5 bathrooms and 4 bedrooms.

Mr. Chan explained that all bedrooms on the second floor have one bathroom, but there is a half bathroom on the first floor, and one bathroom on the third floor for the multi-purpose room so that the residents do not have to go to the second floor to use the bathroom.

Commissioner Arvizu asked how they decided on the size and square footage of the units.

Mr. Chan stated that the developer decided on the size of the units.

Mr. Chan also circled back to the question about subterranean parking and explained that it is not as popular as it was in the past. Instead, developers are opting to have parking at ground level with a third floor of living space.

Chair Tsoi suggested making the replacement tree smaller in order to fit more trees.

Chair Tsoi asked if the trash enclosure could be relocated so that it is toward the rear of the property. Perhaps it can be swapped with one of the guest parking spaces.

Ms. MacCarley said due to the dimensions it was not possible to swap the guest parking with the trash enclosure.

Robert Ip introduced himself as the owner's representative and spoke in favor of the project.

Doris Arbour introduced herself as an Arcadia resident of more than 50 years and spoke in opposition to the project. She had concerns with the size of the development and potential traffic issues. She also submitted a letter to the Planning Commission that expressed her concerns.

Jeanie Tarj introduced herself as a neighbor and expressed some concerns about the height of the structures and the potential increase in traffic to the area.

Chair Tsoi invited the Applicant back up to the podium if he would like to address any of the comments or concerns before they closed the public hearing.

Mr. Chan spoke for the last time and reiterated that his project is in compliance and follows all the guidelines and requirements.

Commissioner Tallerico made a motion to close the public hearing. Vice Chair Wilander seconded the motion.

Without objection, the motion was approved.

DISCUSSION

Commissioner Arvizu thought the proposed development was a nice design and listed some of the elements that he thought were attractive, however, he believed the development was larger than the other developments in terms of scale of mass and was concerned this will set a precedent for other proposals. Commissioner Arvizu also stated that he could not make one of the findings pertaining to the General Plan Land Use Policy No. LU 4-1 that the new development will be consistent in scale, mass, and character with the other structures within the surrounding neighborhood.

Vice Chair Wilander agreed with Commissioner Arvizu and stated that the proposed development looks very large and that it is one of her concerns. Ms. Wilander also stated she agreed with the number of proposed replacement trees.

Commissioner Tallerico shared the same concerns but recognizes that all findings have been made.

Commissioner Hui said the proposal has a nice curb appeal and thought it was comparable to other projects. Ms. Hui had no objection and was in favor of the project.

Chair Tsoi stated he liked the architectural style of the project and that it adds character to the neighborhood. Mr. Tsoi added that he would like to see more additional landscaping on the property and that the trash enclosure be concealed more than it already is so that it is out of public view. He also asked if the front yard setback is larger than other properties, and Ms. MacCarley stated that Second Avenue has a larger setback than other streets due to a special setback but that this property has already dedicated that setback that is why the building is situated further back.

MOTION

It was moved by Commissioner Arvizu, seconded by Vice Chair Wilander to deny the project on the basis that he could not make Tentative Tract Map letter A, that the proposed map, subdivision design and improvements were not consistent with the General Plan, specifically to General Plan Land Use Policy No. LU 4-1 in that the new development will not visually and functionally integrated in terms of scale, mass, and character with the other structures in the surrounding neighborhood. Therefore, he recommended denial of Multiple Family Architectural Design Review No. MFADR 23-03, Tentative Tract Map No. TTM 23-05 (84291), Healthy Tree Removal No. TRH 23-04, and Protected Tree Encroachment No. TRE 23-10 for 16-unit Contemporary style, multi-family residential condominium development at 314-326 S. Second Avenue.

ROLL CALL

AYES: Vice Chair Wilander and Commissioner Arvizu
NOES: Chair Tsoi, Commissioners Hui, and Tallerico
ABSENT: None

The motion failed.

Chair Tsoi called for another motion.

It was moved by Commissioner Tallerico, seconded by Commissioner Hui to adopt Resolution No. 2142 approving Multiple Family Architectural Design Review No. MFADR 23-03, Tentative Tract Map No. TTM 23-05 (84291), Healthy Tree Removal No. TRH 23-04, and Protected Tree Encroachment No. TRE 23-10 for 16-unit Contemporary style, multi-family residential condominium development at 314-326 S. Second Avenue, and all the requisite findings were made and it is exempt from CEQA.

ROLL CALL

AYES: Chair Tsoi, Commissioners Hui, and Tallerico
NOES: Vice Chair Wilander and Commissioner Arvizu
ABSENT: None

The motion was approved.

There is a 10-day appeal period. Appeals are to be filed by 5:30 p.m. on Monday, March 25, 2024.

CONSENT CALENDAR

- 1. Minutes of the February 27, 2024, Regular Meeting of the Planning Commission

Recommendation: Approve

Vice Chair Wilander motioned to approve the minutes and seconded by Commissioner Hui.

ROLL CALL

AYES: Chair Tsoi, Vice Chair Wilander, Commissioners Arvizu, Hui, and Tallerico
NOES: None
ABSENT: None

The motion was approved.

MATTERS FROM CITY COUNCIL LIAISON

City Council Member Kwan had nothing to report.

MATTERS FROM THE PLANNING COMMISSIONERS

Vice Chair Wilander and Commission Hui asked for updates about several businesses. Ms. Flores provided an update to all their questions.

Commissioner Tallarico informed the Commissioners that he will be giving a presentation of hostile architecture at the next meeting along with an update about what he learned from the Planning Commission Academy.

MATTERS FROM CITY ATTORNEY

City Attorney Mike Maurer had nothing to report.

MATTERS FROM STAFF INCLUDING UPCOMING AGENDA ITEMS

Ms. Flores reported that there will be no items for the March 26 meeting, and it will be cancelled. The next meeting will be on April 9.

ADJOURNMENT

The Planning Commission adjourned the meeting at 8:13p.m., to Tuesday, April 9, 2024, at 7:00 p.m. in the City Council Chamber.

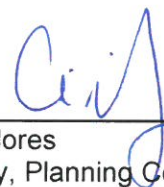

Chair Tsoi, Planning Commission

ATTEST: 

Lisa L. Flores
Secretary, Planning Commission

Attachment No. 4

Tentative Tract Map No. 84291

TENTATIVE TRACT NO. 84291

IN THE CITY OF ARCADIA, COUNTY OF LOS ANGELES
STATE OF CALIFORNIA

BEING A SUBDIVISION OF A PORTION OF BLOCK 59 OF THE SANTA ANITA TRACT, COUNTY OF LOS ANGELES, STATE OF CALIFORNIA, AS PER MAP RECORDED IN BOOK 34, PAGES 41 AND 42 OF MISCELLANEOUS RECORDS, IN THE OFFICE OF THE COUNTY RECORDER OF SAID COUNTY.

FOR CONDOMINIUM PURPOSES

NORTH

SCALE: 1"=20'-0"

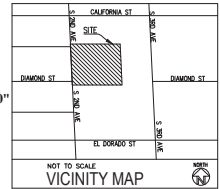

OWNER: SMART PROPERTY LA II LLC 713 W DUARTE RD #G, ARCADIA, CA 91007

PREPARED BY:
HANK JONG, PE
EG&A ASSOCIATES, INC.
1819 GOLDING ROAD, UNIT A
ARCADIA, CA 91008
PH: 909-283-3556
EMAIL: HJONG@EG&A.COM

UTILITY SERVICES:

- WATER - CITY OF ARCADIA PUBLIC WORK
- SEWER - CITY OF ARCADIA PUBLIC WORK
- GAS - SOUTHERN CALIFORNIA GAS CO.
- ELECTRICITY - SOUTHERN CALIFORNIA EDISON CO.
- TELEPHONE - AT&T
- SCHOOL - ARCADIA CITY UNIFIED SCHOOL DISTRICT
- FIRE - CITY OF ARCADIA FIRE DEPARTMENT
- POLICE - CITY OF ARCADIA SHERIFF DEPARTMENT

BENCH MARK

- CITY BENCHMARK 8066
SECOND AVE AND CALIFORNIA ST
- NORTHWEST CURBRETURN, S' NORTH
ELEV = 446.52'
- SURVEY WAS PROVIDED BY ALFRED J. THELMELL
LS 6999 ON JUNE 1, 2022, MANAGED BY HANK JONG

SPECIAL NOTES:

THE PROJECT SITE IS NOT IN A POTENTIAL HAZARDOUS AREA.

GENERAL NOTES:

- ZONE: R-2 (PRESENT)
- ZONE: R-2 (PROPOSED)
- NO. OF EX. UNITS: 16
- NO. OF PROP. UNIT: 16 UNITS
- NO. OF EX. LOT: 4
- NO. OF PROP. LOTS: 1
- AREA OF LOT: 59439.74 SQ. FT. (1.36 ACRES)
- NO. OF PROP. PARKING: 32 COVERED PARKING + 8 GUEST PARKING + 8 BICYCLE PARKING.
- SEWERAGE DISPOSAL: BY GRAVITY SEWER PIPES TO SEWER MAIN.
- APHN: 5779-004-025, 026, 027 & 028.

CONSTRUCTION NOTES:

- REMOVE EXISTING DRIVEWAY APPROACHES AND CONSTRUCT NEW DRIVEWAY APPROACH PER CITY STANDARDS.
- CONSTRUCT NEW CONC. PAVEMENT.
- REMOVE EX. DRIVEWAY APPROACH AND RECONSTRUCT NEW SIDEWALK, CURB AND GUTTER CONNECT TO EXISTING.
- REMOVE AND REPLACE CURB AND GUTTER WITH 2 ASPHALT SLOT CUT FROM PROPERTY LINE TO PROPERTY LINE.
- REMOVE AND REPLACE NEW SIDEWALK PROVIDING ADEQUATE PATH OF TRAVEL IN COMPLIANCE WITH AMERICANS WITH DISABILITIES ACT (ADA). ENSURE LOCATIONS AROUND OBSTRUCTIONS PROVIDE NECESSARY CLEARANCES.

EASEMENT NOTES:

- 6" SOCIAL EDISON POWER LINE EASEMENT RECORDED IN 1993-2943, OF OFFICIAL RECORDS.
- 6" SOCIAL EDISON POWER LINE EASEMENT RECORDED IN 1990-2909, OF OFFICIAL RECORDS.
- 6" SOCIAL EDISON PUBLIC UTILITY EASEMENT RECORDED IN 1994-2948, OF OFFICIAL RECORDS.
- 12" SOCIAL EDISON POWER LINE EASEMENT RECORDED IN 1999-3266, OF OFFICIAL RECORDS TO BE OBTAINED.

SEE THESE PROTECTIVE NOTES:
ALL CONSTRUCTION SHALL OCCUR THAT ALL NECESSARY MEASURES ARE IN PLACE TO PREVENT ANY OR ALL UTILITIES FROM BEING DAMAGED. FOR THE PROTECTED NOTES (HORIZONTAL) BEHIND PROTECTIVE PROPERTY OF THE NEW PROTECTIVE CURB WALL, MINIMUM 10" FROM THE OUTSIDE EDGE OF THE TRUCK, MUST BE IN PLACE AT ALL TIMES. EXCAVATION MAY BE REQUIRED TO ALLOW FOR NECESSARY NECESSARY CONSTRUCTION, GRADING, COMPACTOR OR REPAIRING, NO STORAGE OF MATERIALS, DEBRIS OR SOILS, AND NO REMOVAL OF OBSTRUCTIONS OR EQUIPMENT ARE ALLOWED WITHIN THE 10" ZONE. ANY DAMAGE TO ANY UTILITIES SHALL BE REPAIRED BY THE CONTRACTOR. ALL UTILITIES SHALL BE DEEPER THAN THE PROTECTIVE CURB WALL. ALL UTILITIES SHALL BE DEEPER THAN THE PROTECTIVE CURB WALL. ALL UTILITIES SHALL BE DEEPER THAN THE PROTECTIVE CURB WALL.

DEMOLITION NOTES:

- REMOVE EXISTING STRUCTURE.
- REMOVE EXISTING TREE.

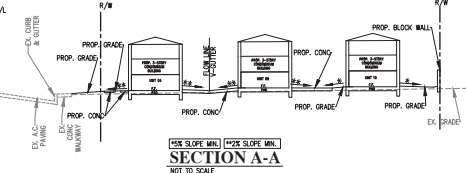

SECTION A-A
NOT TO SCALE

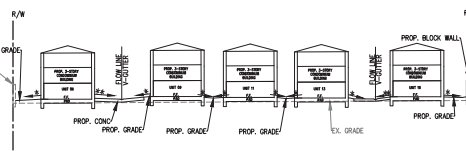

SECTION B-B
NOT TO SCALE

LEGEND:

- (182.63) - EXISTING ELEVATION
- (184.00) - PROPOSED ELEVATION
- (185) - EXISTING CONTOUR
- DRAINAGE PATTERN
- PROPOSED STRUCTURE
- BOUNDARY LINE
- PROPOSED WALL
- WM - WATER METER
- CB - CATCH BASIN
- TO - TOP GRADE
- FS - FINISH SURFACE
- F.F. - FINISH FLOOR
- H.P. - HIGH POINT
- T.C. - TOP OF CURB
- LANDSCAPE
- EXISTING BUILDING
- DECOMPOSED GRANITE

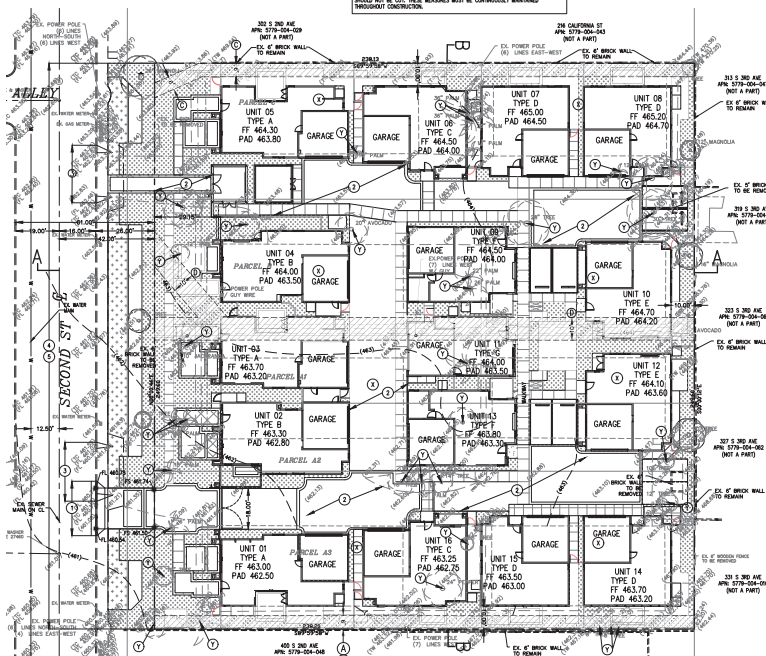

16 UNITS MULTIFAMILY
RESIDENTIAL
314-326 S. 2ND AVE.,
ARCADIA, CA 91008

REVISIONS BY

NO.	DATE	BY	DESCRIPTION

RELEASED DATE

SMART PROPERTY
LA L L L L C
713 W DUARTE RD #G,
ARCADIA, CA 91007

EG&A Associates, Inc.
1819 GOLDING ROAD, UNIT A
ARCADIA, CA 91008
TEL: (909) 283-3556
FAX: (909) 283-3557
WWW.EG&A.COM

DATE	REVISION
10/17/2023	
22-203-007	

DRAWING 1 of 1

T-1

Attachment No. 5

Architectural Plans



16 UNITS MULTIFAMILY RESIDENTIALS

314-326 2ND AVE ARCADIA, CA 91007

SHEET INDEX

0	COVER SHEET
0.1	MATERIAL BOARD
0.2	SETBACK ANALYSIS
0.3	FLOOR AREA ANALYSIS
0.4	SITE AREA ANALYSIS
1.0	SITE PLAN
1.1	TOPOGRAPHIC SURVEY
1.2	EXISTING TREE PLAN
1.3	TRASH ENCLOSURE/COMMON OPEN SPACE
2.1	FLOOR PLAN - TYPE A
2.2	FLOOR PLAN - TYPE B
2.3	FLOOR PLAN - TYPE C
2.4	FLOOR PLAN - TYPE D
2.5	FLOOR PLAN - TYPE E
2.6	FLOOR PLAN - TYPE F
2.7	FLOOR PLAN - TYPE G
3.1	ELEVATIONS - TYPE A
3.2	ELEVATIONS - TYPE B
3.3	ELEVATIONS - TYPE C
3.4	ELEVATIONS - TYPE D
3.5	ELEVATIONS - TYPE E
3.6	ELEVATIONS - TYPE F
3.7	ELEVATIONS - TYPE G
4.0	SCHEDULE / DETAILS
5.0	ISOMETRIC VIEWS
6.1	LANDSCAPE PLAN

ARCHITECTURAL PLANS
PREPARED BY: PDS STUDIO INC



PDS STUDIO, Inc. | ARCHITECTURE + DESIGN
711 S FIRST AVE., ARCADIA, CA 91006
WWW.PDS-STUDIO.COM
E: MAIL@PDS-STUDIO.COM
P: (626) 294-9402



EXTERIOR FINISH SCHEDULE

1. CEMENT PLASTER - CRYSTAL WHITE (LA HABRA STUCCO)
 - FINISH SAND STUCCO FINISH, COLOR: X-50
2. PRECAST/CONCRETE/PC/ART FAIRFAX (LA HABRA STUCCO)
 - STUCCOED, COLOR: CRYSTAL WHITE, X-50
3. EXTERIOR WINDOWS (MILGARD WINDOWS) (MILGARD)
 - COLLECTION: TUSCANY VINYL
 - COLOR: BLACK
4. WOODWORK / DECORATIVE VENT / DECORATIVE WOOD BRACKET
 - PAINTED, COLOR: DEW341 SWISS COFFEE (DUNN-EDWARDS)
5. COMPOSITE SLATE ROOF TILE (DAVING ROOFCAP)
 - SINGLE WIDTH SLATE, COLOR: EUROPEAN
6. FASCIA BOARD (MILWORK BY OTHERS)
 - 2x4 FASCIA BOARD, PAINTED
 - COLOR: DEW341 SWISS COFFEE (DUNN-EDWARDS)
7. CROWN MOULDING (LA HABRA STUCCO)
 - STUCCOED, COLOR: CRYSTAL WHITE, X-50
8. EXTERIOR LIGHTING
 - COLOR: BLACK
 - DOWNWARD FACING LIGHT AT SIDE FACING
9. BRICK VENEER (EL DORADO BRICKS, TUNDRA CHALK DUST)
 - COLLECTION: EL DORADO BRICKS, TUNDRA CHALK DUST
10. VERTICAL COMPOSITE CLADDING (NEWTECHWOOD)
 - ULTRABEAD CLADDING, 1/2" THICK, COLOR: BRAZILIAN IPE
11. GARAGE DOOR (AMARR GARAGE DOOR)
 - LINCOLN COLLECTION, COLOR: BLACK
12. DOWNSTROKE / LEAKPROOF / FAN GUTTER
 - COLOR COATED ALUMINUM, COLOR: BLACK
13. RAILING AT BALCONY
 - GLASS WITH BLACK IRON
14. VINYL FINISHING / GATE
 - PAINTED: DEW341 SWISS COFFEE
15. STANDING SEAM METAL ROOF
 - COLOR: BLACK
16. METAL AWNING
 - COLOR: BLACK



PDS STUDIO
ARCHITECTURE + DESIGN

771 S. FIRST AVE.
ARCHAON, CA 91504
TEL: 626-294-7422
WWW.PDS-STUDIO.COM

ARCHITECT SEAL:



PROJECT:
**14 UNITS MULTIFAMILY
RESIDENTIALS**

314 - 201 2nd AVE
ARCHAON, CA 91504

ISSUE DATE:
1/21/2024 4:15:57 PM

PROJECT NO.:
REVISION: DATE

NOTES:

CHECKED BY: Checker

DATE:

ISSUE NAME:

MATERIAL BOARD

ISSUE NO.:

0.1

 METAL ROOF W/ STANDING SEAM COLOR: BLACK	 EXTERIOR LIGHTING COLOR: BLACK	 WOODWORK VENT BRACKET (PAINTED) DEW341 SWISS COFFEE (DUNN EDWARDS PAINT)	 EUROPEAN STYLE COMPOSITE SIDING (NEWTECHWOOD) COLOR: BRAZILIAN IPE	 50 CRYSTAL WHITE BASE 100 CEMENT PLASTER 50 CRYSTAL WHITE
 LOUVRE SLAT AWNING COLOR: BLACK	 EXTERNAL GLASS RAILING COLOR: BLACK	 EXTERIOR WINDOWS (MILGARD) TUSCANY VINYL, COLOR: BLACK	 ELDERADO STONE, ELDERADO BRICK COLOR: TUNDRA CHALK DUST	 COMPOSITE SLATE ROOF COLOR: EUROPEAN

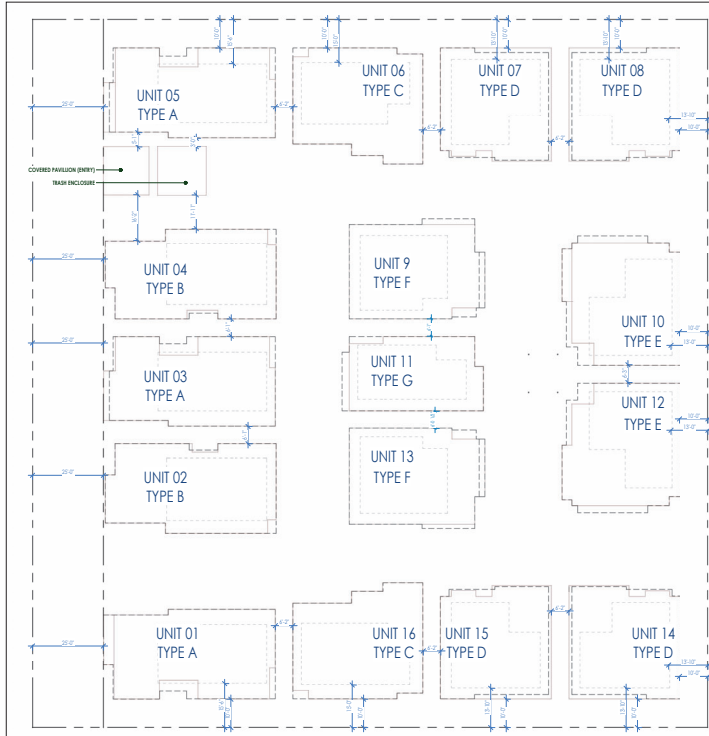

SITE PLAN SETBACK ANALYSIS
1/16" = 1'-0"

FLOOR LINE LEGEND	
	1st FLOOR LINE
	2nd FLOOR LINE
	3rd FLOOR LINE

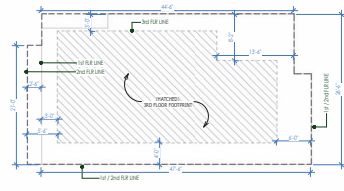

SETBACK - TYPE G
1/8" = 1'-0" (7)

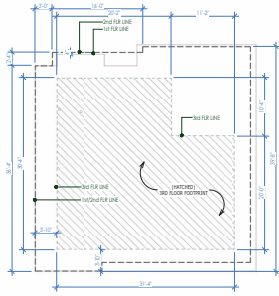

SETBACK - TYPE D
1/8" = 1'-0" (4)

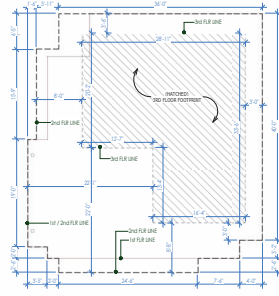

SETBACK - TYPE E
1/8" = 1'-0" (5)

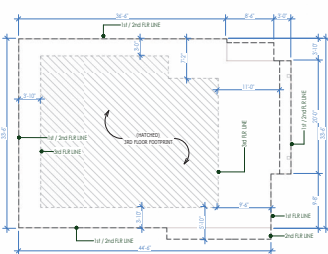

SETBACK - TYPE F
1/8" = 1'-0" (6)

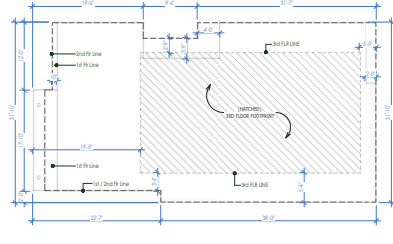

SETBACK - TYPE A
1/8" = 1'-0" (1)

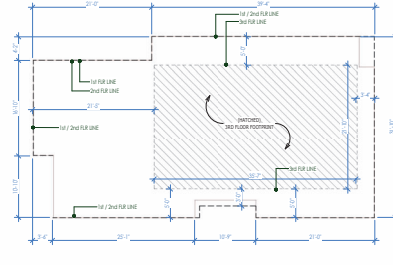

SETBACK - TYPE B
1/8" = 1'-0" (2)

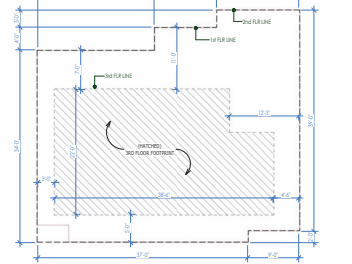

SETBACK - TYPE C
1/8" = 1'-0" (3)



ARCHITECTURE + DESIGN
771 S. FIRST AVE.
ARCHIBOL, CA 94524
TEL: 925-294-7422
WWW.PDS-STUDIO.COM



PROJECT: 14 UNITS MULTIFAMILY RESIDENTIALS

314 - 2nd St AVE
ARCHIBOL, CA 94524

PROJECT DATE: 1/23/2024 4:14:03 PM
PROJECT NO: C-38915
REVISION: DATE:

NOTES:

CHECKED BY: Checker
DESIGNED BY: Archibol
PROJECT NAME: SETBACK ANALYSIS

SHEET NO:

0.2

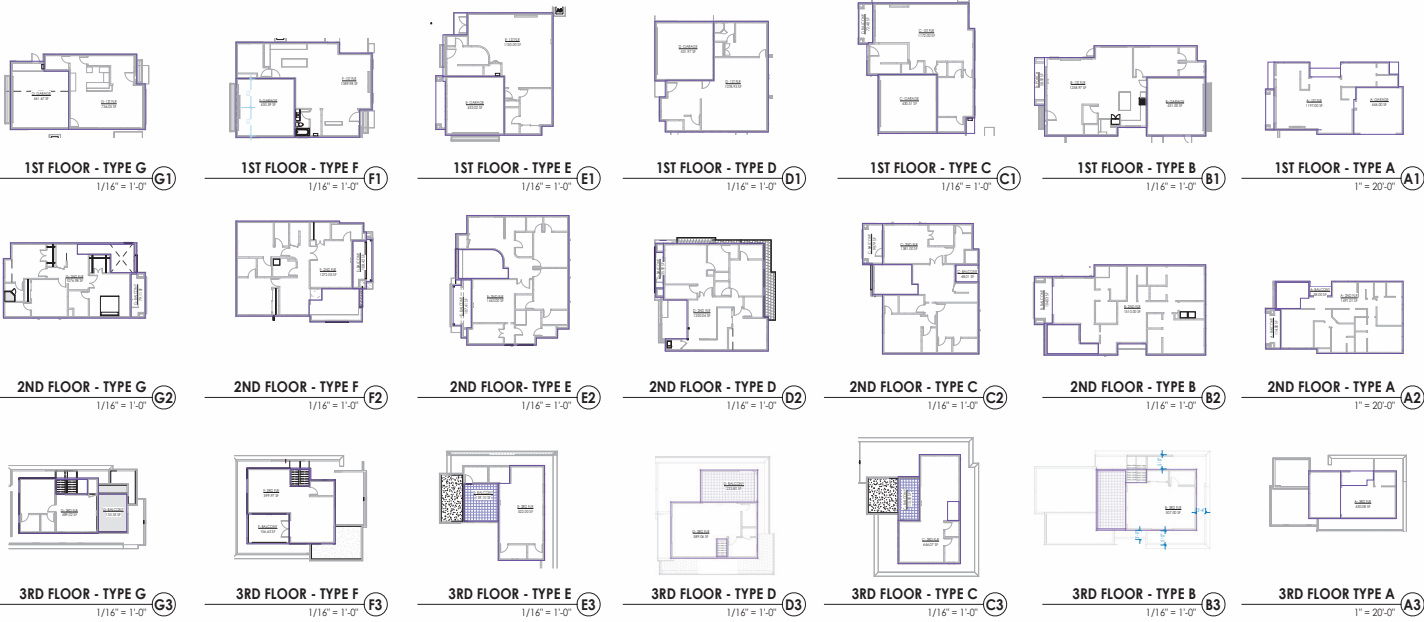

PROJECT: 14 UNITS MULTIFAMILY RESIDENTIALS

314 - 201 2nd AVE
ARCHANA, CA 95020

PROJECT DATE: 5/23/2024 4:18:13 PM
PROJECT NO.:
REVISION: DATE:

NOTES:

CHECKED BY: Checker
DATE: 5/23/2024
DRAWN BY: Arndt
DATE:

FLOOR AREA ANALYSIS

Sheet No.

0.3

GARAGE AREA	
A- GARAGE	446 SF
B- GARAGE	431 SF
C- GARAGE	431 SF
D- GARAGE	432 SF
E- GARAGE	431 SF
F- GARAGE	432 SF
G- GARAGE	432 SF
Total Living Area: 3,044 SF	

TYPE E LIVING AREA	
E- 1ST FLR	1,150 SF
A- 2ND FLR	1,463 SF
E- 3RD FLR	522 SF
Total Living Area: 3,135 SF	

TYPE A LIVING AREA	
A- 1ST FLR	1,977 SF
A- 2ND FLR	1,491 SF
A- 3RD FLR	430 SF
Total Living Area: 3,118 SF	

TYPE F LIVING AREA	
F- 1ST FLR	1,090 SF
F- 2ND FLR	1,272 SF
F- 3RD FLR	490 SF
Total Living Area: 2,942 SF	

TYPE B LIVING AREA	
B- 1ST FLR	1,259 SF
B- 2ND FLR	1,510 SF
B- 3RD FLR	507 SF
Total Living Area: 3,276 SF	

TYPE G LIVING AREA	
G- 1ST FLR	756 SF
G- 2ND FLR	1,077 SF
G- 3RD FLR	490 SF
Total Living Area: 2,303 SF	

TYPE C LIVING AREA	
C- 1ST FLR	1,172 SF
C- 2ND FLR	1,381 SF
C- 3RD FLR	444 SF
Total Living Area: 3,199 SF	

TYPE D LIVING AREA	
D- 1ST FLR	1,079 SF
D- 2ND FLR	1,220 SF
D- 3RD FLR	589 SF
Total Living Area: 2,918 SF	

BALCONY AREA	
A- BALCONY	151 SF
B- BALCONY	124 SF
C- BALCONY	336 SF
D- BALCONY	260 SF
E- BALCONY	260 SF
F- BALCONY	252 SF
G- BALCONY	212 SF
Total Living Area: 1,598 SF	

UNIT SUMMARY						
TYPE	COUNT	LIVING AREA	BED	BATH	PARKING	
TYPE A	3	3,118 SF	4	5.5	2 STANDARD	
TYPE B	2	3,276 SF	4	5.5	2 STANDARD	
TYPE C	2	3,199 SF	4	5.5	2 STANDARD	
TYPE D	4	2,918 SF	4	5.5	2 STANDARD	
TYPE E	2	3,135 SF	4	5.5	2 STANDARD	
TYPE F	2	2,942 SF	4	5.5	2 STANDARD	
TYPE G	1	2,303 SF	4	5.5	2 STANDARD	
14						

UNIT AREA SUMMARY				
UNIT	TYPE	LIVING AREA	GARAGE AREA	BALCONY AREA
1	TYPE A	3,118 SF	446 SF	152 SF
2	TYPE B	3,276 SF	431 SF	104 SF
3	TYPE A	3,118 SF	446 SF	152 SF
4	TYPE B	3,276 SF	431 SF	104 SF
5	TYPE A	3,118 SF	446 SF	152 SF
6	TYPE C	3,199 SF	431 SF	336 SF
7	TYPE D	2,918 SF	432 SF	260 SF
8	TYPE D	2,918 SF	432 SF	260 SF
9	TYPE F	2,942 SF	431 SF	265 SF
10	TYPE E	3,135 SF	432 SF	267 SF
11	TYPE G	2,303 SF	432 SF	212 SF
12	TYPE E	3,135 SF	432 SF	267 SF
13	TYPE F	2,942 SF	431 SF	265 SF
14	TYPE D	2,918 SF	432 SF	260 SF
15	TYPE D	2,918 SF	432 SF	260 SF
16	TYPE C	3,199 SF	431 SF	336 SF
48,472 SF				

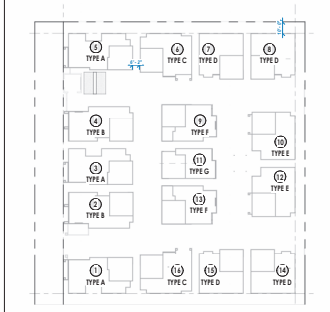

AREA SCHEDULE

UNIT AREA / TYPE SCHEDULE

KEY PLAN

COMMON OPEN SPACE	
COMMON OPEN SPACE	633.12 SF
	633.12 SF

OPEN SPACE PER UNIT	
UNIT 1 - PRIVATE OPEN SPACE	475.05 SF
UNIT 2 - PRIVATE OPEN SPACE	179.21 SF
UNIT 3 - PRIVATE OPEN SPACE	179.22 SF
UNIT 4 - PRIVATE OPEN SPACE	186.85 SF
UNIT 5 - PRIVATE OPEN SPACE	475.05 SF
UNIT 6 - PRIVATE OPEN SPACE	593.16 SF
UNIT 7 - PRIVATE OPEN SPACE	451.76 SF
UNIT 8 - PRIVATE OPEN SPACE	650.00 SF
UNIT 9 - PRIVATE OPEN SPACE	423.71 SF
UNIT 10 - PRIVATE OPEN SPACE	101.89 SF
UNIT 11 - PRIVATE OPEN SPACE AT BALCONY	132.72 SF
UNIT 12 - PRIVATE OPEN SPACE	439.13 SF
UNIT 13 - PRIVATE OPEN SPACE	101.89 SF
UNIT 14 - PRIVATE OPEN SPACE	650.00 SF
UNIT 15 - PRIVATE OPEN SPACE	451.76 SF
UNIT 16 - PRIVATE OPEN SPACE	639.21 SF

HARDSCAPE AT FRONT YARD CALCULATION
 MAX ALLOWABLE HARDSCAPE AREA = 12406.40 = 2.49% SF
 PROPOSED HARDSCAPE AREA = 2.447 SF (1.45% MAX)

PRIVATE OPEN SPACE / COMMON OPEN SPACE
 PRIVATE OPEN SPACE PER UNIT = 100 SF MINIMUM

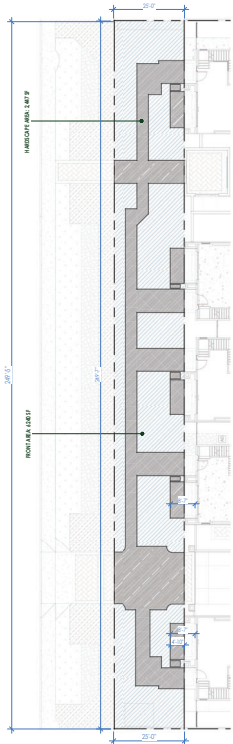

FRONT YARD AREA CALCULATION
 1/16" = 1'-0" ②

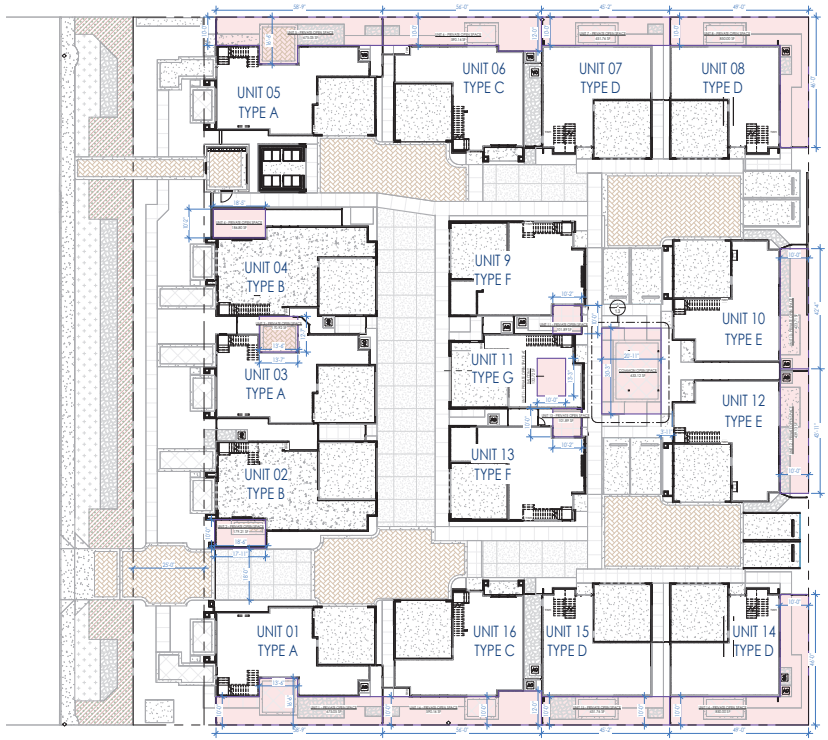

OPEN SPACE AREA PLAN
 1/16" = 1'-0" ①

PDS STUDIO
 ARCHITECTURE + DESIGN
 771 S. FIRST AVE.
 ANCHORAGE, AL 99501
 TEL: 408-294-7402
 WWW.PDS-STUDIO.COM



PROJECT: 14 UNITS MULTIFAMILY RESIDENTIALS

304 - 202 2nd AVE ANCHORAGE, AL 99501

PROJECT DATE: 1/28/2024 4:14:30 PM

PROJECT NO.: _____

REVISION: _____ DATE: _____

NOTES:

CHECKED BY: Checker

SCALE: 1/16" = 1'-0"

SHEET NAME: SITE AREA ANALYSIS

SHEET NO.:

0.4

ADDITIONAL NOTES

- LANDING:**
- A. THIS PROJECT MUST COMPLY WITH THE CITY'S WATER SPECIFIC LANDSCAPING ORDINANCE (WLSO).
 - B. CONSIDERATIONS SHOULD BE MADE IN THE LANDSCAPE DESIGN CONCEPT PLANS TO COMPLY WITH THE ORDINANCE.
- PUBLIC WORKS:**
- A. SINCE THE PROPOSED PROJECT EXCEEDS 1 ACRE OF DEVELOPED LAND, APPLICANTS MUST FILE A NOTICE OF INTENT (NOI) WITH THE STATE WATER RESOURCES CONTROL BOARD FOR A GENERAL CONSTRUCTION PERMIT AND AN APPLICABLE FEE TO THE STATE WATER RESOURCES CONTROL BOARD.
 - B. THE PROPOSED PROJECT IS SUBJECT TO LD REQUIREMENTS. THESE REQUIREMENTS INCLUDE USING NEW BRONZE BRUSHED ALUMINUM FINISH FOR ROOF DRAIN CONNECTED TO A LANDSCAPE AREA, FURNISH CONCRETE PAVEMENT, ETC.
 - C. DEVELOPER SHALL PROVIDE A SWIRE AREA STUDY TO DETERMINE WHETHER OR NOT THE CITY SEWER LINE ON SECOND AVE. IS CAPABLE OF HANDLING ALL ANTICIPATED PEAK FLOW DEMANDS OF THE PROPOSED IMPROVEMENTS.
- USE:**
- A. A NEW PUBLIC HYDRANT SHALL BE PROVIDED ON THE STREET FRONTAGE AT AN APPROVED LOCATION.
- REGULATIONS:**
- A. COORDINATE WITH UTILITY COMPANIES TO UNDERGROUND ALL UTILITIES (INCLUDING BUT NOT LIMITED TO CABLE TELEVISION, TELEPHONE, AND ELECTRICAL SYSTEMS). NEW POWER POLES ARE PERMITTED BY CITY OF ARCADIA STANDARD CONDITIONS OF APPROVAL.
 - B. RECOMMENDATIONS REQUIRED BY SOUTHERN CALIFORNIA Edison TO UPGRADE THE SYSTEM, IF IT IS TO BE PLACED CROSSING OF THE PUBLIC HIGHWAY OR ANY OTHER PRIVATE PROPERTY.
 - C. THE DEVELOPER SHALL MAKE THE FOLLOWING PUBLIC IMPROVEMENTS:
 - 1. REMOVE AND REPLACE EXISTING SEWER, CURB AND GUTTER ALONG THE PROPERTY FRONTAGE OF SECOND AVENUE.
 - 2. CONSTRUCT NEW DRIVEWAY APPROACH PER CITY STANDARD B011.

APPLICABLE CODES

- 2022 CALIFORNIA BUILDING CODE
- 2022 CALIFORNIA MECHANICAL CODE
- 2022 CALIFORNIA ELECTRICAL CODE
- 2022 CALIFORNIA PLUMBING CODE
- 2022 CALIFORNIA FIRE CODE
- 2022 CALIFORNIA ENERGY CODE
- 2022 CALIFORNIA GREEN BUILDING STANDARD CODE
- 2022 CALIFORNIA LOCAL ORDINANCES

SITE PLAN NOTES

- A. APPROVED BUILDING ADDRESS NUMBERS, BUILDING NUMBER, OR APPROVED BUILDING IDENTIFICATION SHALL BE PROVIDED AND MARKED SO AS TO BE PLAINLY VISIBLE AND LEGIBLE FROM THE STREET FRONTING THE PROPERTY. THE NUMBERS SHALL CONTRAST WITH THEIR BACKGROUND, BE ARABIC NUMBERS OR ALPHABET LETTERS, AND BE A MINIMUM OF FOUR FEET HIGH WITH A MINIMUM STROKE WIDTH OF 0.5 INCH. (SEE CODE SECTION 1).
- B. ALL ROOF COVERINGS SHALL BE CLASS 'A' AS SPECIFIED IN BUILDING CODE SECTION 11. RECOMMEND CODE R022.2 AND PROJ. SEE SHEET A-29.
- C. ROOF VALLEY FLASHING SHALL BE NOT LESS THAN 0.01 INCH (NO. 26 CHAINWIRE) FREE CAGES CORROSION RESISTANT METAL INSTALLED OVER A MIN. 3/8 INCH WIDE UNDERLAMENT CONSISTING OF ONE LAYER OF NO. 17 ALUMINUM PEEB METING BARRING THE FULL LENGTH OF THE VALLEY. RESIDENTIAL CODE R027.5.3 AND BUILDING CODE T024.3.

- D. RAIN GUTTERS SHALL BE PROVIDED WITH A HEARD TO PREVENT ACCUMULATION OF LEAVES AND DEBRIS IN THE GUTTER (R027.5.3, CEC 25A.4).
- E. VENTS SHALL RESIST THE INTRODUCTION OF FLAME AND EMBERS AND FLAME THROUGH THE VENTILATION OPENING. VENT OPENINGS SHALL BE PROTECTED BY CORROSION RESISTANT, NONCOMBUSTIBLE WIRE MESH WITH A MIN. 1/8 INCH OPENINGS AND SHALL NOT EXCEED 1/4 INCH. VENTS SHALL NOT BE INSTALLED IN LAIVES OR CORNICES.
- F. EMERGENCY ESCAPE LIGHTING TO BE PROVIDED PER 2019 CALIFORNIA FIRE SECTION 109.
- G. CURB, GUTTERS AND SIDEWALKS MAY BE REQUIRED TO BE REMOVED AND REPLACED PER CITY STANDARD.

GENERAL NOTES

- A. ROOF-MOUNTED VENTS SHALL BE PAINTED TO MATCH ROOFING MATERIAL.
- B. VERIFY DRAINAGE 2% AWAY FROM FOUNDATION.
- C. VERIFY THAT THE CONSTRUCTION WILL NOT BUILD OVER ON EXISTING SEWER.
- D. ALL WORK SHALL COMPLY WITH THE FOLLOWING CODES INCLUDING LOCAL ORDINANCES.
- E. UTILITIES SHALL BE UNDERGROUND.
- F. BUILDING ADDRESS SHALL BE PROVIDED ON THE BUILDING IN SUCH A POSITION AS TO BE PLAINLY VISIBLE AND LEGIBLE FROM THE STREET.
- G. ADDRESS NUMBERS ARE TO BE 4" TALL WITH 1/2" STROKE PER CEC R019.
- H. EACH PROJECT WILL BE RESPONSIBLE OF THE OTHER, WITH UTILITIES SERVING THE UNITS THROUGH THE COMMON AREA, WITH NO UTILITIES OR DRAINAGE CROSSING INDIVIDUAL LOTS.

SCOPE OF WORK

CONSTRUCT SIXTEEN (16), THREE-STORY, DETACHED RESIDENTIAL UNITS IN (RESIDENTIAL MEDIUM DENSITY) R-2 ZONE, ALL EXISTING TO BE DEMOLISHED

PROJECT DATA

ADDRESS / APN: 3143 2ND AVE, ARCADIA CA 91006 APN: 3791704028
 320 S 2ND AVE, ARCADIA CA 91006 APN: 3791704027
 324 S 2ND AVE, ARCADIA CA 91006 APN: 3791704026
 328 S 2ND AVE, ARCADIA CA 91006 APN: 3791704025

ZONE: R-2
 CONSTRUCTION TYPE: V-4 FRR SPRINKLER NFA 130
 LOT AREA: 86,000 SQ. FT.
 NUMBER OF STORY: 3
 EXISTING DENSITY: 14 UNITS
 MAX DENSITY: 12 UNITS (9429.744 / 3750 = 15.8)
 PROPOSED DENSITY: 12 UNITS
 14 UNITS (TO MATCH EXISTING)

SEWERAGE: 20" DI.
 FRONT YARD: 20' DI. x 10'
 REAR YARD: 20' DI. x 10'
 REAR BUILDING SEPARATION: 10' DI. x 6' 0" 2ND FLOOR 6' 0"

GUEST PARKING: 8 (14 UNITS / 1.75)
 PROVIDED: 8 GUEST PARKING PROVIDED
 8 STANDARDS

COVERED PARKING: 32 COVERED (2 x 14 UNITS)
 PROVIDED: 32 COVERED PARKING

TOTAL PARKING: 40 TOTAL PARKING SPACES

BIKE PARKING: 4 MIN 10' PER UNIT, 2 x 14 = 28
 PROVIDED: 8 PROVIDED

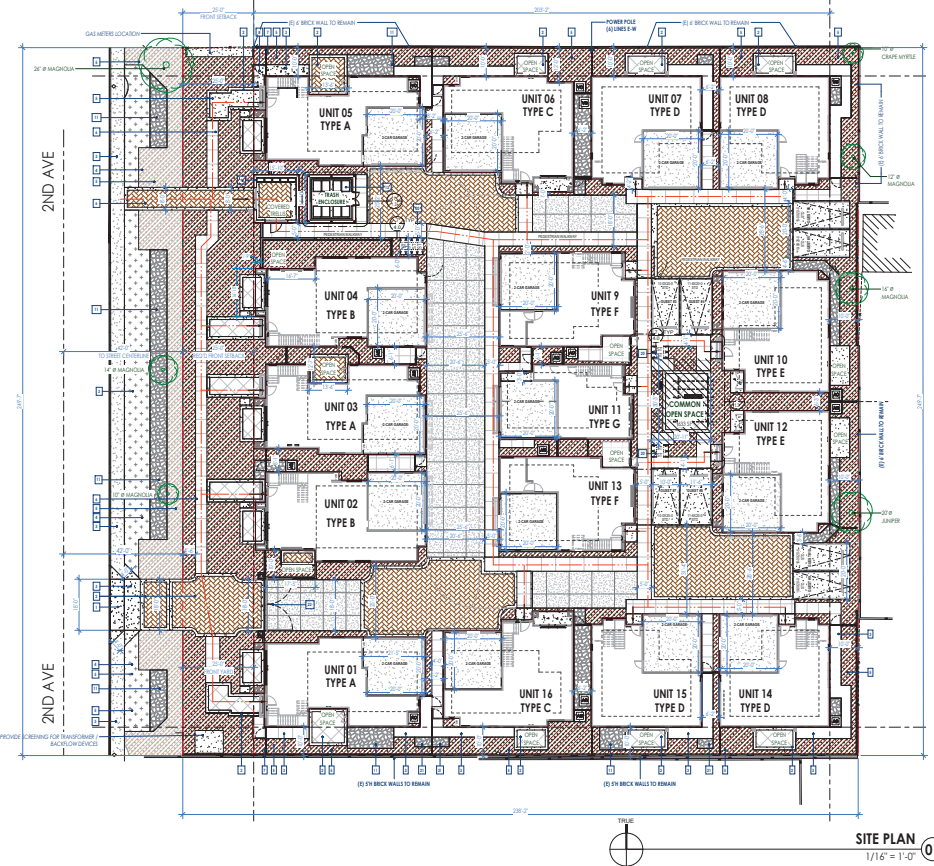

SITE PLAN KEYNOTE	
#	KEY DESCRIPTION
1	NEW DRIVEWAY APPROACH PER CITY STANDARDS
2	CONCRETE (C-CURED) W/ 10' BORDERS
3	CONCRETE WALKWAY
4	LAWN / TURF AREA
5	LANDSCAPED AREA
6	RESTRICTION WALKWAY W/ INTERLOCKING PAVERS
7	SH VINYL FENCING, COLOR: WHITE
8	SH VINYL GATE, COLOR: WHITE
9	IN 4" 6" CMU WALL 30" HIGH ON NEIGHBOR SIDE & STUCCO FIN. ON PROJECT SIDE
10	BUILDING OVERHANG
11	DECOMPOSED GRANITE / GRAVEL AREA
12	CONCRETE LANDSCAPING
13	TRASH ENCLOSURE
14	20' MIN. MIN ELECTRICAL PANEL
15	LOCATION OF GUEST PARKING STALLS (PROVIDE MIN 11" WIDTH FOR STALL ADJACENT TO WALLS)
16	30" MIN MAX GARDEN WALL
17	AC / MECHANICAL UNIT
18	SCORED CONCRETE WALKWAY DARKER COLOR
19	LANDSCAPE HEDGE
20	BMS STALL WITH 2" MIN SPACING
21	PRIVATE BIN STORAGE AREA
22	DECORATIVE W/ DRIVEWAY GATE, 4" HT MAX, COLOR: BLACK
23	OUTDOOR LIGHTING TO BE SHIELDED FROM ADJOINING PROPERTIES AND STREETS

UNIT TYPE SUMMARY					
TYPE	COUNT	LIVING AREA	BED	BATH	PARKING
TYPE A	3	3,118 SF	4	5.5	2 STANDARD
TYPE B	2	3,276 SF	4	5.5	2 STANDARD
TYPE C	2	3,199 SF	4	5.5	2 STANDARD
TYPE D	4	2,918 SF	4	5.5	2 STANDARD
TYPE E	2	3,158 SF	4	5.5	2 STANDARD
TYPE F	2	2,842 SF	4	5.5	2 STANDARD
TYPE G	1	2,302 SF	4	5.5	2 STANDARD



ARCHITECTURE + DESIGN
 771 S. FIRST AVE.
 ARCADIA, CA 91006
 TEL: 626-294-9422
 WWW.PDS-STUDIO.COM



14 UNITS MULTIFAMILY
 RESIDENTIALS
 314 - 328 2nd Ave
 ARCADIA CA 91006

PROJECT NO.: 1
 PROJECT DATE: 5/23/2024 4:18:23 PM
 PREPARED BY: [Name]
 CHECKED BY: [Name]

DATE: [Blank]
 SCALE: 1/16" = 1'-0"

DATE: [Blank]
 SCALE: 1/16" = 1'-0"

DATE: [Blank]
 SCALE: 1/16" = 1'-0"

DATE: [Blank]
 SCALE: 1/16" = 1'-0"

DATE: [Blank]
 SCALE: 1/16" = 1'-0"

DATE: [Blank]
 SCALE: 1/16" = 1'-0"



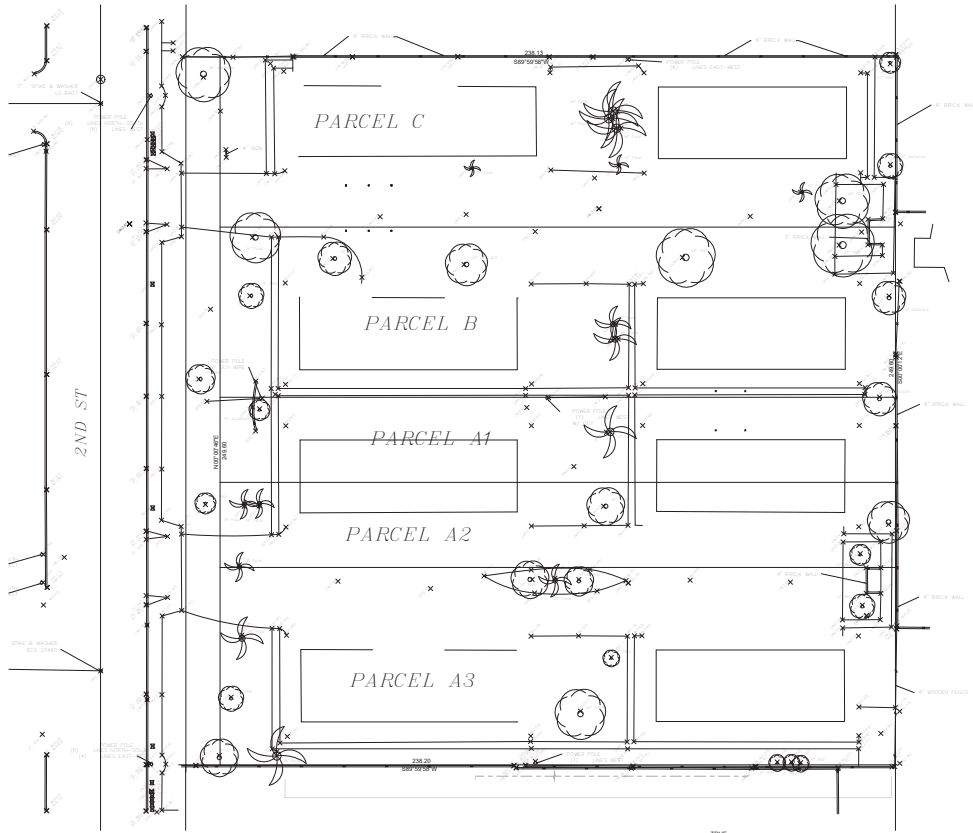

TRUE
TOPOGRAPHIC SURVEY
1/16" = 1'-0" ①



PDS STUDIO
ARCHITECTURE + DESIGN
771 S. FIRST AVE.
ARCHAUL, CA 97524
TEL: 531-214-1422
WWW.PDS-STUDIO.COM



PROJECT:
14 UNITS MULTIFAMILY
RESIDENTIALS

214 - 2nd St
ARCHAUL, CA 97524

PROJECT DATE:
1/21/2024 4:14:26 PM

PROJECT NO.:
REVISION: DATE:

NOTES:

CHECKED BY: Checker

SCALE: 1/16" = 1'-0"

SHEET NAME:
TOPOGRAPHIC SURVEY

SHEET NO.:
1.1

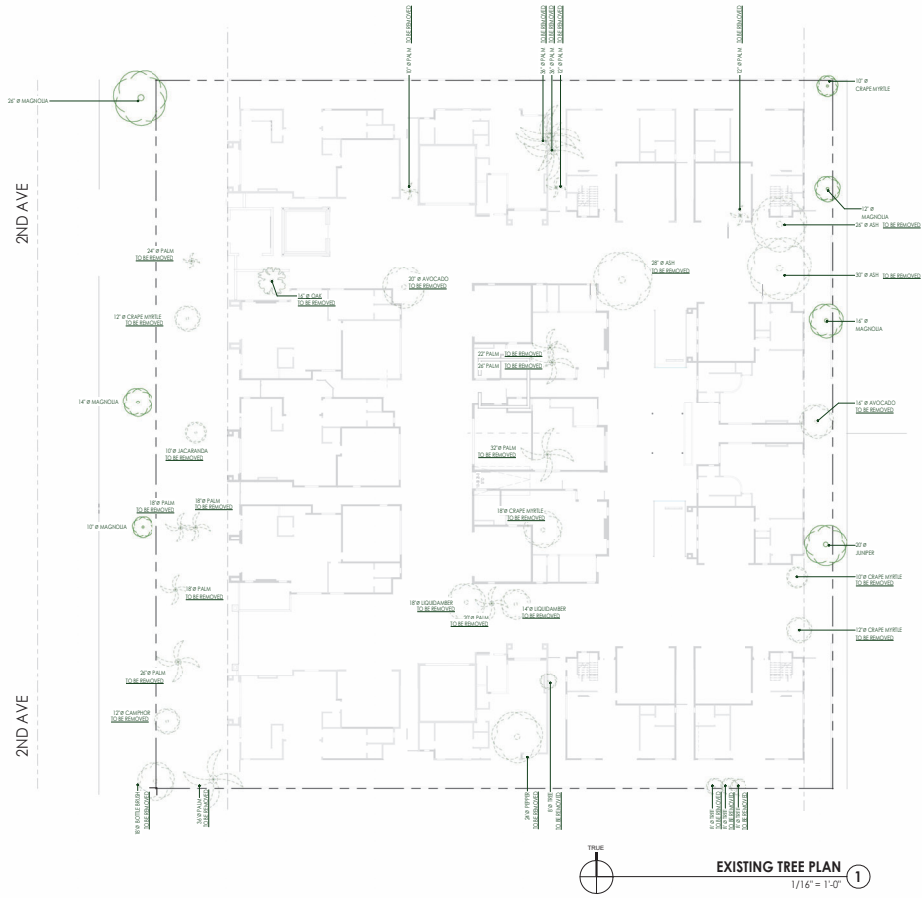

TREE LEGEND

TREE TO REMAIN	TREE TO BE REMOVED
OAK TREE	PALM TREE

EXISTING TREE PLAN
1/16" = 1'-0"

PDS STUDIO
ARCHITECTURE + DESIGN
771 S. FIRST AVE.
ARCHAULA, CA 95524
TEL: 408-294-7422
WWW.PDS-STUDIO.COM

ARCHITECT SEAL:

PROJECT:
14 UNITS MULTIFAMILY
RESIDENTIALS

214 - 201 2ND AVE
ARCHAULA, CA 95524

PROJECT DATE:
1/21/2024 4:14:30 PM

PROJECT NO.:
REVISION: DATE:

NOTES:

CHECKED BY:
DATE: 01/21/24
DRAWN BY:
DATE: 01/21/24
EXISTING TREE PLAN

SHEET NO.:
1.2

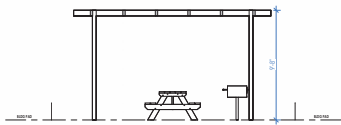

COMMON OPEN SPACE EAST ELEVATION
1/4" = 1'-0" (E)

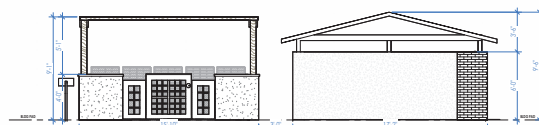

SOUTH ELEVATION
1/4" = 1'-0" (C)

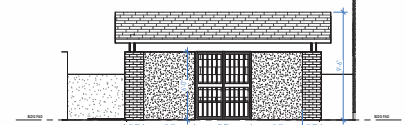

EAST ELEVATION
1/4" = 1'-0" (A)

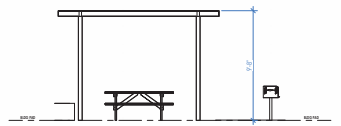

COMMON OPEN SPACE NORTH ELEVATION
1/4" = 1'-0" (F)

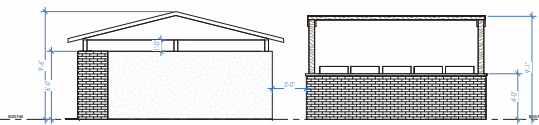

NORTH ELEVATION
1/4" = 1'-0" (D)

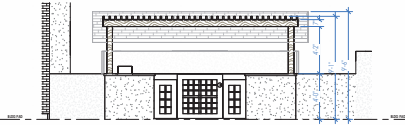

WEST ELEVATION
1/4" = 1'-0" (B)

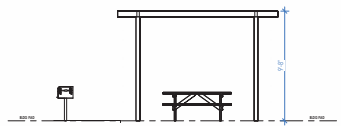

COMMON OPEN SPACE SOUTH ELEVATION
1/4" = 1'-0" (G)

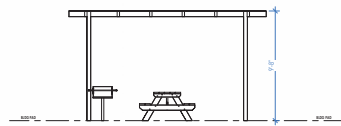

COMMON OPEN SPACE WEST ELEVATION
1/4" = 1'-0" (H)

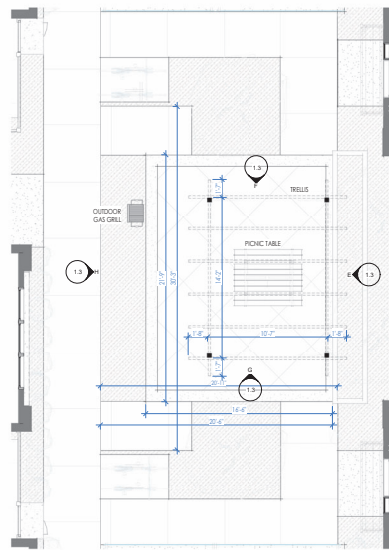

COMMON OPEN SPACE
1/4" = 1'-0" (3)

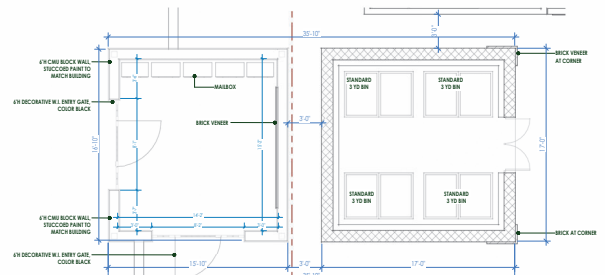

TRASH ENCLOSURE / PAVILLION PLAN
1/4" = 1'-0" (1)

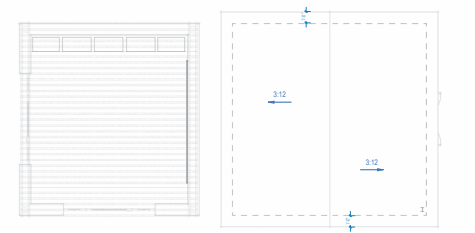

TRASH ENCLOSURE / PAVILLION ROOF PLAN
1/4" = 1'-0" (2)



PROJECT:
14 UNITS MULTIFAMILY
RESIDENTIALS

314 - 201 2nd AVE
ARCHON, CA 91501

PROJECT DATE:
5/23/2024 4:18:36 PM

PROJECT NO.:

REVISION DATE:

REVISION DATE:

REVISION DATE:

REVISION DATE:

REVISION DATE:

REVISION DATE:

REVISION DATE:

REVISION DATE:

REVISION DATE:

REVISION DATE:

REVISION DATE:

REVISION DATE:

REVISION DATE:

REVISION DATE:

REVISION DATE:

REVISION DATE:

REVISION DATE:

REVISION DATE:

REVISION DATE:

REVISION DATE:

REVISION DATE:

REVISION DATE:

REVISION DATE:

REVISION DATE:

REVISION DATE:

REVISION DATE:

REVISION DATE:

REVISION DATE:

REVISION DATE:

REVISION DATE:

REVISION DATE:

REVISION DATE:

REVISION DATE:

REVISION DATE:

REVISION DATE:

REVISION DATE:

REVISION DATE:

REVISION DATE:

REVISION DATE:

REVISION DATE:

REVISION DATE:

REVISION DATE:

REVISION DATE:

REVISION DATE:

REVISION DATE:

REVISION DATE:

REVISION DATE:

REVISION DATE:

REVISION DATE:

REVISION DATE:

REVISION DATE:

REVISION DATE:

REVISION DATE:

REVISION DATE:

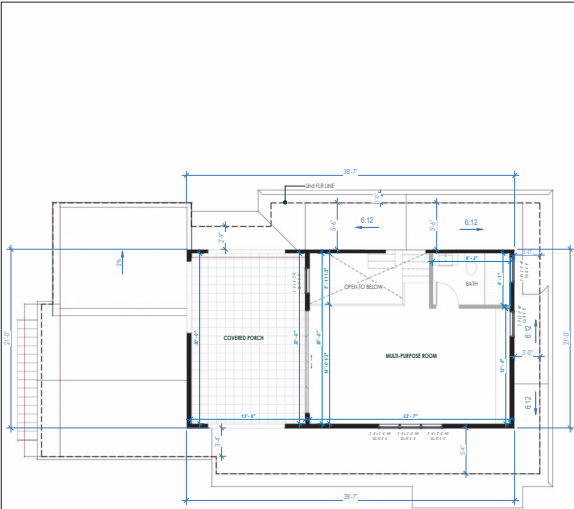

3RD FLOOR - TYPE A
3/16" = 1'-0" ③

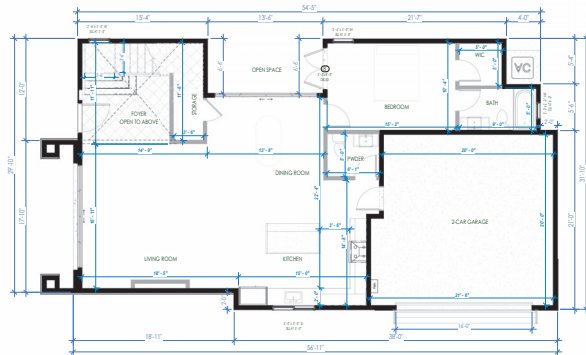

1ST FLOOR PLAN - TYPE A (UNIT 1, UNIT 5)
3/16" = 1'-0" ①

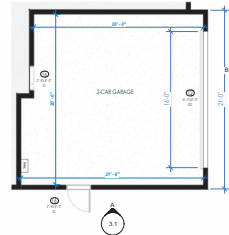

GARAGE AT TYPE A (UNIT 3)
3/16" = 1'-0" ③

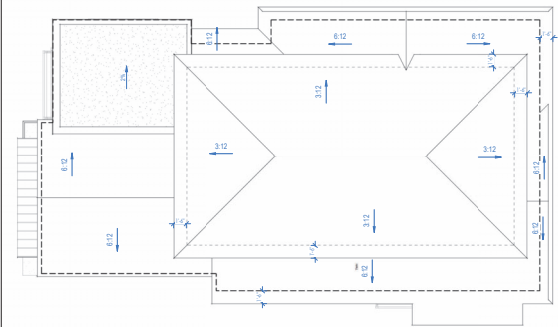

ROOF PLAN - TYPE A
3/16" = 1'-0" ④

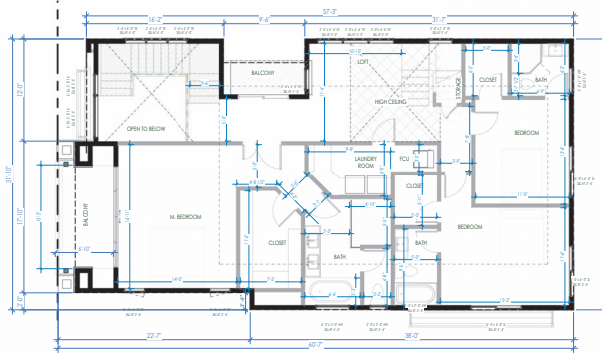

2ND FLOOR - TYPE A
3/16" = 1'-0" ②

TYPE A LIVING AREA	
A- 1ST FLR	1,197 SF
A- 2ND FLR	1,491 SF
A- 3RD FLR	430 SF
Total Living Area:	3,118 SF

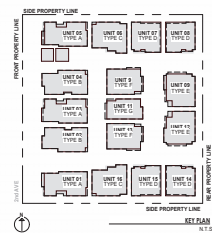

PDS STUDIO

ARCHITECTURE + DESIGN
771 S. FIRST AVE.
ARCHAON, CA 97524
TEL: 530-214-7402
WWW.PDS-STUDIO.COM

ARCHITECT SEAL:



PROJECT:
**14 UNITS MULTIFAMILY
RESIDENTIALS**

314 - 202 2nd AVE
ARCHAON, CA 97524

PROJECT DATE:
1/28/2024 4:23:57 PM

PROJECT NO.:

REVISION: _____ DATE: _____

NOTES:

CHECKED BY: Checker

DESIGNED BY: ArchiChecker

FLOOR PLAN - TYPE A

SHEET NO.:

2.1

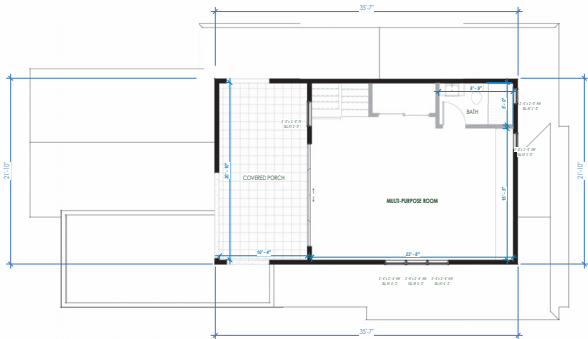

3RD FLOOR - TYPE B
3/16" = 1'-0"

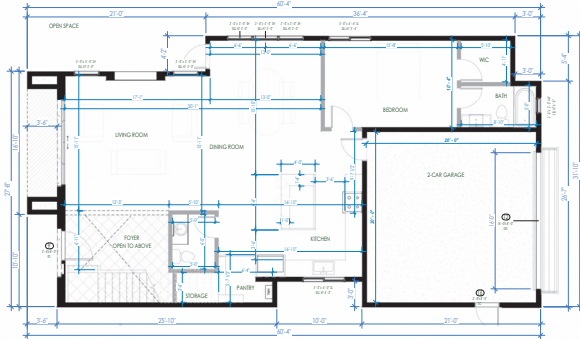

1ST FLOOR - TYPE B
3/16" = 1'-0"

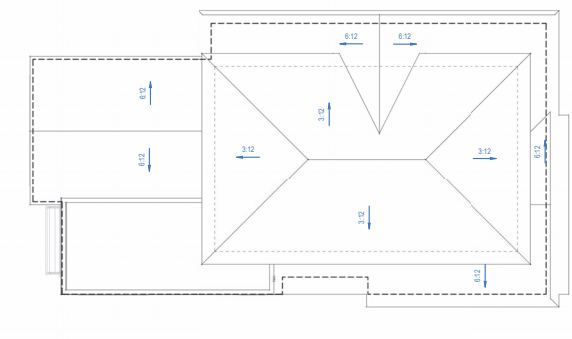

ROOF PLAN - TYPE B
3/16" = 1'-0"

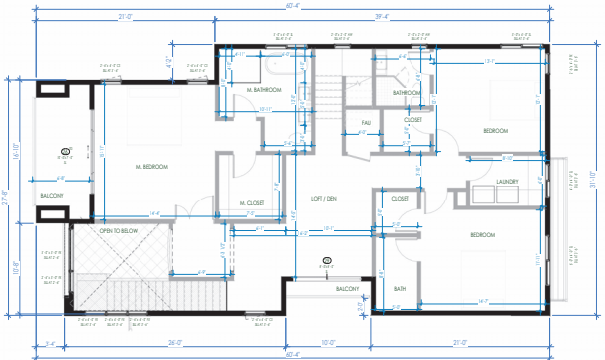

2ND FLOOR - TYPE B
3/16" = 1'-0"

TYPE B LIVING AREA	
B-1ST FLR	1,259 SF
B-2ND FLR	1,510 SF
B-3RD FLR	507 SF
Total Living Area: 3,276 SF	

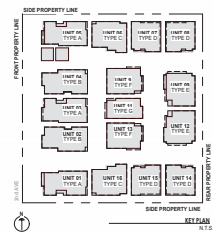

PDS STUDIO
ARCHITECTURE + DESIGN
771 S. FIRST AVE.
ARCHAUL, CA 95524
TEL: 408-294-9402
WWW.PDS-STUDIO.COM

ARCHITECT SEAL:



PROJECT:
**14 UNITS MULTIFAMILY
RESIDENTIALS**

214 - 201 2nd AVE
ARCHAUL, CA 95524

ISSUE DATE:
1/31/2024 4:24:01 PM

PROJECT NO.:

REVISION DATE:

NOTES:

CHECKED BY: Checker

ISSUED: ArchiChecker

FLOOR PLAN - TYPE B

ISSUE NO.:

2.2

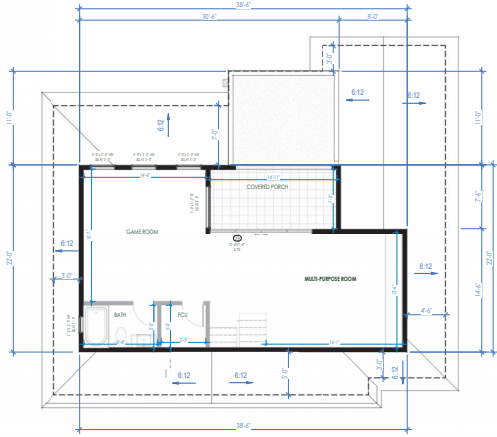

3RD FLOOR - TYPE C
3/16" = 1'-0"

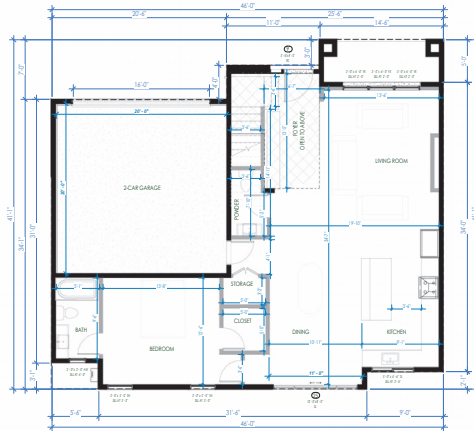

1ST FLOOR - TYPE C
3/16" = 1'-0"

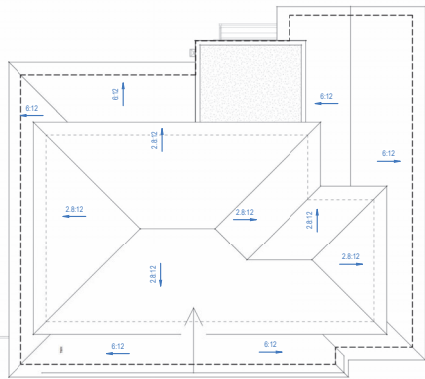

ROOF PLAN - TYPE C
3/16" = 1'-0"

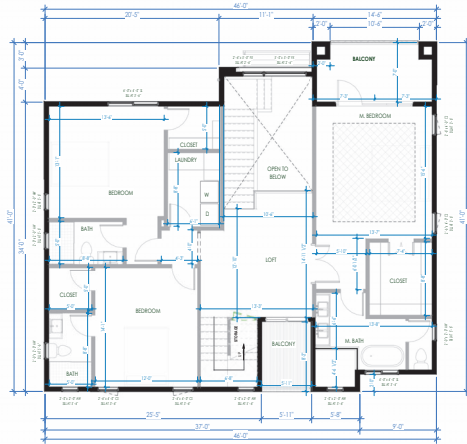

2ND FLOOR - TYPE C
3/16" = 1'-0"

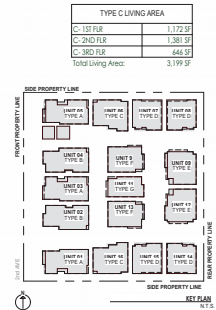

PDS STUDIO

ARCHITECTURE + DESIGN
771 S. FIRST AVE.
MICHIGAN, CA 91554
TEL: 651-214-1402
WWW.PDS-STUDIO.COM

ARCHITECT SCALE:



PROJECT:
**14 UNITS MULTIFAMILY
RESIDENTIALS**

314 - 201 2nd AVE
MICHIGAN CA 91554

PROJECT DATE:
1/21/2024 4:24:04 PM

PROJECT NO.:

REVISION DATE:

NOTES:

CHECKED BY: Checker

DESIGNED BY: Architect

FLOOR PLAN - TYPE C

SHEET NO.:

2.3

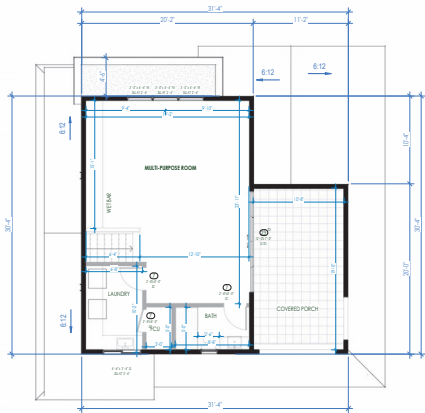

3RD FLOOR - TYPE D
3/16" = 1'-0" ③

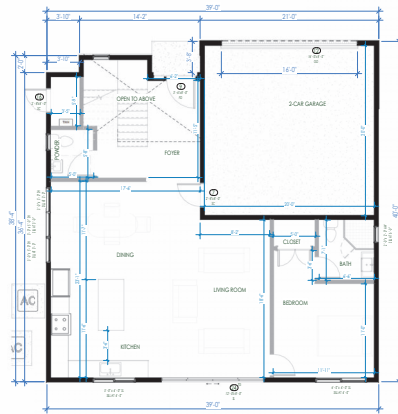

1ST FLOOR - TYPE D
3/16" = 1'-0" ①

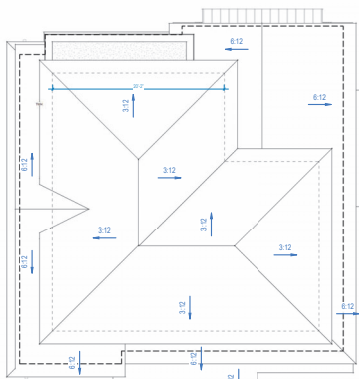

ROOF PLAN - TYPE D
3/16" = 1'-0" ④

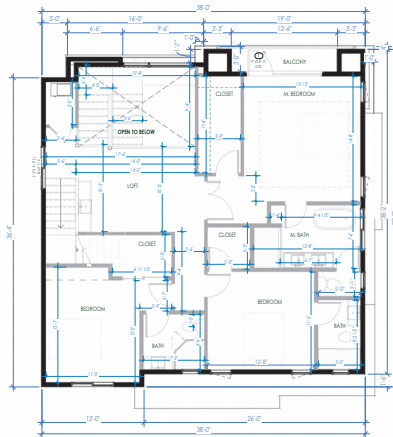

2ND FLOOR - TYPE D
3/16" = 1'-0" ②

TYPE D LIVING AREA	
1ST FLOOR	1,079 SF
2ND FLOOR	1,250 SF
3RD FLOOR	889 SF
Total Living Area:	2,718 SF



PDS STUDIO

ARCHITECTURE + DESIGN
771 S. FIRST AVE.
ARCHAON, CA 91504
TEL: 651-214-1402
WWW.PDS-STUDIO.COM

ARCHITECT SEAL:



PROJECT:
**14 UNITS MULTIFAMILY
RESIDENTIALS**

314 - 202 2nd AVE
ARCHAON, CA 91504

ISSUE DATE:
1/28/2024 4:24:07 PM

PROJECT NO.:

REVISION DATE:

NOTES:

CHECKED BY: Checker

DESIGNED BY: Architect

FLOOR PLAN - TYPE D

ISSUE NO.:

2.4

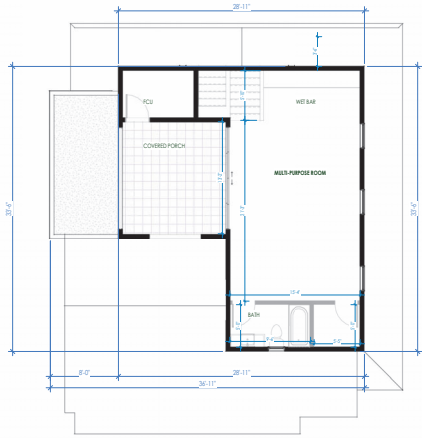

3RD FLOOR - TYPE E
3/16" = 1'-0" ③

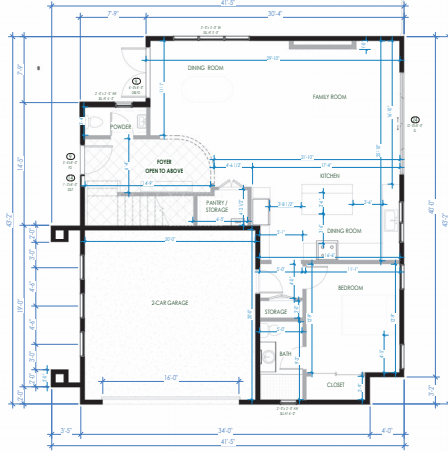

1ST FLOOR PLAN - TYPE E
3/16" = 1'-0" ①

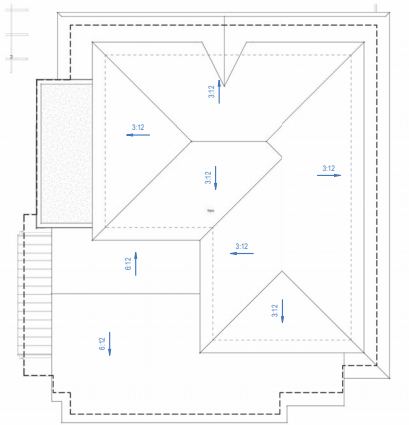

ROOF PLAN - TYPE E
3/16" = 1'-0" ④



2ND FLOOR - TYPE E
3/16" = 1'-0" ②

TYPE E LIVING AREA	
E-1ST FLR	1,150 SF
E-2ND FLR	1,463 SF
E-3RD FLR	522 SF
Total Living Area:	3,135 SF

KEY PLAN
N.T.S.



PDS STUDIO

ARCHITECTURE + DESIGN
771 S. FIRST AVE.
ARCHAUL, CA 91504
TEL: 626-214-1402
WWW.PDS-STUDIO.COM

ARCHITECT SEAL:



PROJECT:
**14 UNITS MULTIFAMILY
RESIDENTIALS**

314 - 201 2nd AVE
ARCHAUL, CA 91504

PROJECT DATE:
1/21/2024 4:24:10 PM

PROJECT NO.:

REVISION DATE:

NOTES:

CHECKED BY: Checker

DESIGNED BY: Architect

FLOOR PLAN - TYPE E

SHEET NO.:

2.5

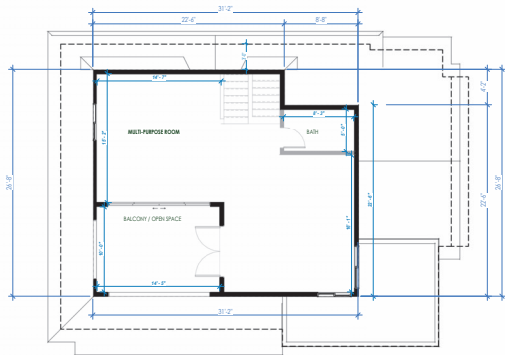

3RD FLOOR - TYPE F
3/16" = 1'-0" ③

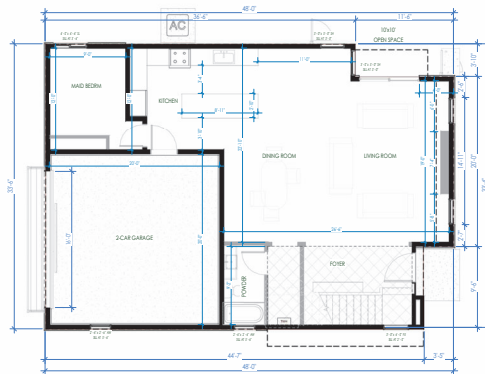

1ST FLOOR - TYPE F
3/16" = 1'-0" ①

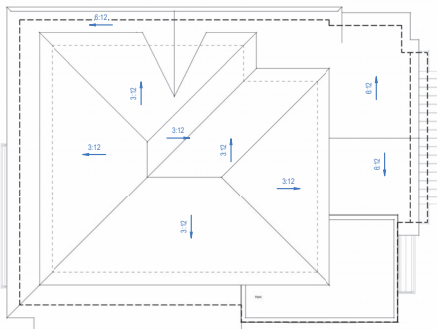

ROOF PLAN - TYPE F
3/16" = 1'-0" ④

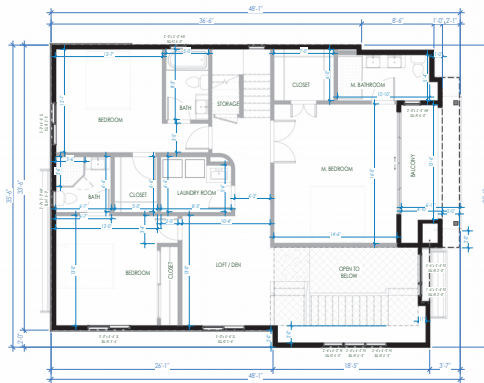

2ND FLOOR - TYPE F
3/16" = 1'-0" ②

TYPE F LIVING AREA	
F-1ST FLR	1,090 SF
F-2ND FLR	1,272 SF
F-3RD FLR	603 SF
Total Living Area: 2,965 SF	

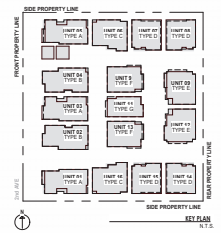

PDS STUDIO

ARCHITECTURE + DESIGN

771 S. FIRST AVE.
MICHIGAN, CA 91554

TEL: 651-214-1402
WWW.PDS-DESIGN.COM

ARCHITECT ID: 1410



PROJECT:

14 UNITS MULTIFAMILY
RESIDENTIALS

314 - 201 2nd AVE
MICHIGAN CA 91554

PROJECT DATE:
1/31/2024 4:24:13 PM

PROJECT NO.:

REVISION: DATE:

NOTES:

CHECKED BY: Checker

DESIGNED BY: Architect

FLOOR PLAN - TYPE F

SHEET NO.:

2.6



PDS STUDIO

ARCHITECTURE + DESIGN

771 S. FIRST AVE.

ARCHAULA, CA 95524

TEL: 435-214-1422

WWW.PDS-STUDIO.COM

ARCHITECT SEAL:



PROJECT:

14 UNITS MULTIFAMILY

RESIDENTIALS

314 - 324 2nd AVE

ARCHAULA, CA 95524

PROJECT DATE:

1/23/2024 4:24:15 PM

PROJECT NO.:

736-21

REVISION DATE:

NOTES:

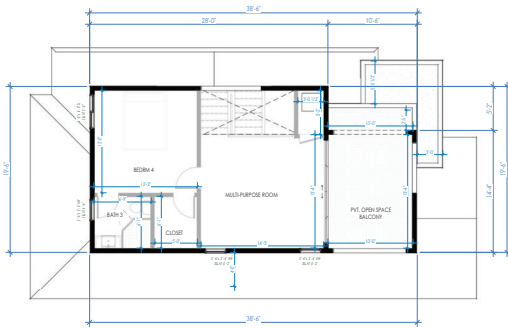

3RD FLOOR - TYPE G
3/16" = 1'-0" ③

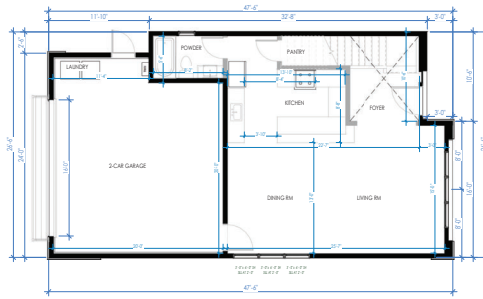

1ST FLOOR - TYPE G
3/16" = 1'-0" ①

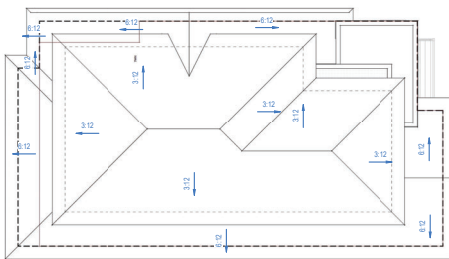

ROOF PLAN - TYPE G
3/16" = 1'-0" ⑧

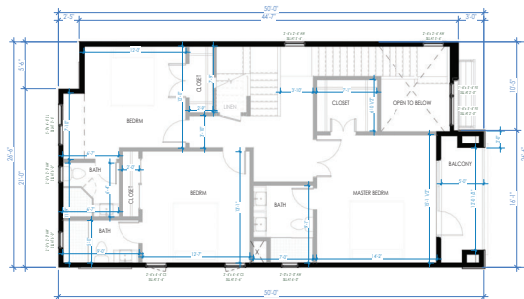

2ND FLOOR - TYPE G
3/16" = 1'-0" ②

TYPE G LIVING AREA	
G-1ST FLS	736 SF
G-2ND FLS	1,077 SF
G-3RD FLS	489 SF
Total Living Area: 2,302 SF	



CHECKED BY: Checker

DATE: 1/23/2024

DESIGNER: Arndt/Chen

FLOOR PLAN - TYPE G

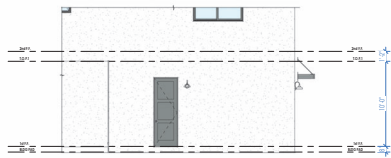

TYPE A - UNIT 3 PARTIAL SIDE 2 ELEVATION
3/16" = 1'-0" (A)



TYPE A - UNIT 3 PARTIAL REAR ELEVATION
3/16" = 1'-0" (B)

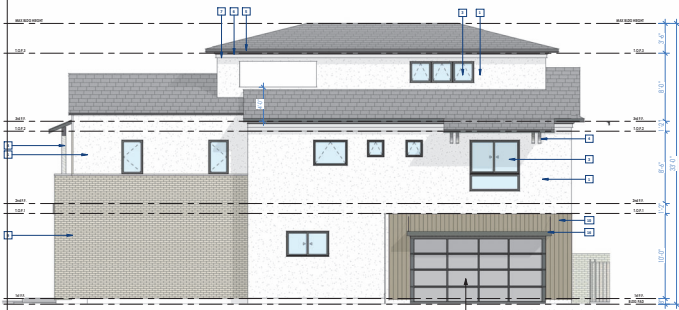

TYPE A - UNIT 1, 5 SIDE 2 ELEVATION
3/16" = 1'-0" (3)

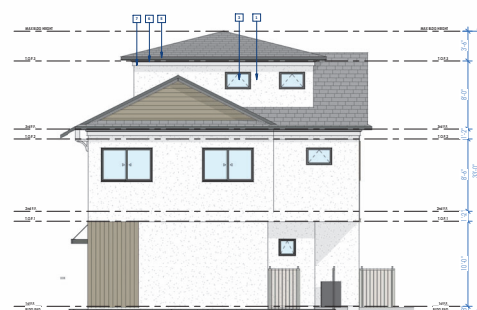

TYPE A - UNIT 1, 5 REAR ELEVATION
3/16" = 1'-0" (1)



TYPE A - SIDE 1 ELEVATION
3/16" = 1'-0" (4)

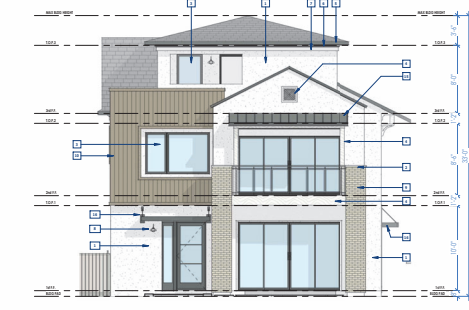

TYPE A - FRONT ELEVATION
3/16" = 1'-0" (2)

EXTERIOR FINISH SCHEDULE

- CEMENT PLASTER - CRYSTAL WHITE (LA HABRA STUCCO)
 - FINISH SAND STUCCO FINISH, COLOR: X-50
- PRECAST IRON / PRECAST CONCRETE PANELS (LA HABRA STUCCO)
 - STUCCOED, COLOR: CRYSTAL WHITE, X-50
- EXTERIOR WINDOWS (MIGARD WINDOWS) (SICCS100-Z)
 - COLLECTION: TUSCANY WHITE
 - COLOR: BLACK
- WOODWORK / DECORATIVE VENT / DECORATIVE WOOD BRACKET
 - PAINTED, COLOR: DEW341 SWISS COFFEE (DUNN-EDWARDS)
- COMPOSITE SLATE ROOF TILE (DAWING ROOFCAPE)
 - SINGLE WIND SLATE, COLOR: EUROPEAN
- FASCIA BOARD (MILWORK BY OTHERS)
 - 2x4 FASCIA BOARD, PAINTED
 - COLOR: DEW341 SWISS COFFEE (DUNN-EDWARDS)
- CROWN MOULDING (LA HABRA STUCCO)
 - STUCCOED, COLOR: CRYSTAL WHITE, X-50
- EXTERIOR LIGHTING
 - COLOR: BLACK
 - DOWNWARD FACING LIGHT AT SIDE FACING
- BRICK VENEER (EL DORADO 310NE)
 - COLLECTION: EL DORADO BRICKS, TUNDRA CHALK DUST
- VERTICAL COMPOSITE CLADDING (NEWTECHWOOD)
 - UNFINISHED CLADDING, BIRCH COLOR BRALIANI PE
- GARAGE DOOR (AMARR GARAGE DOOR)
 - UNICOPY COLLECTION, COLOR: BLACK
- DOWNROOST (LEADHEAD) FAN OUTLET
 - COLOR COATED ALUMINUM, COLOR: BLACK
- RAILING AT BALCONY
 - GLASS WITH BLACK IRON
- VINEY FENCING / GATE
 - PAINTED: DEW341 SWISS COFFEE
- STANDING SEAM METAL ROOF
 - COLOR: BLACK
- METAL AWNING
 - COLOR: BLACK



ARCHITECTURE + DESIGN
771 S. FIRST AVE.
ARCHAIC, CA 91504
TEL: 626-294-7422
WWW.PDS-STUDIO.COM

ARCHITECT SCALE:



PROJECT:
**14 UNITS MULTIFAMILY
RESIDENTIALS**

314 - 202 2nd AVE
ARCHAIC CA 91504

PROJECT DATE:
1/21/2024 4:24:18 PM

PROJECT NO.:

REVISION DATE:

REVISION DATE:

REVISION DATE:

REVISION DATE:

REVISION DATE:

REVISION DATE:

REVISION DATE:

REVISION DATE:

REVISION DATE:

REVISION DATE:

REVISION DATE:

REVISION DATE:

REVISION DATE:

REVISION DATE:

REVISION DATE:

REVISION DATE:

REVISION DATE:

REVISION DATE:

REVISION DATE:

REVISION DATE:

REVISION DATE:

REVISION DATE:

REVISION DATE:

REVISION DATE:

REVISION DATE:

REVISION DATE:

REVISION DATE:

REVISION DATE:

REVISION DATE:

REVISION DATE:

REVISION DATE:

REVISION DATE:

REVISION DATE:

REVISION DATE:

REVISION DATE:

REVISION DATE:

REVISION DATE:

REVISION DATE:

REVISION DATE:

REVISION DATE:

REVISION DATE:

REVISION DATE:

REVISION DATE:

REVISION DATE:

REVISION DATE:

REVISION DATE:

REVISION DATE:

REVISION DATE:

REVISION DATE:

REVISION DATE:

REVISION DATE:

REVISION DATE:

REVISION DATE:

REVISION DATE:

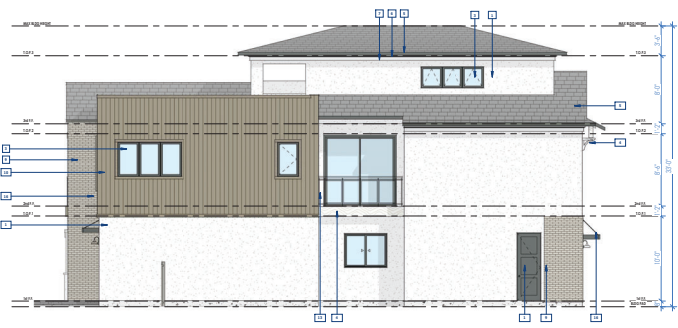

TYPE B - SIDE 2 ELEVATION
3/16" = 1'-0" ③

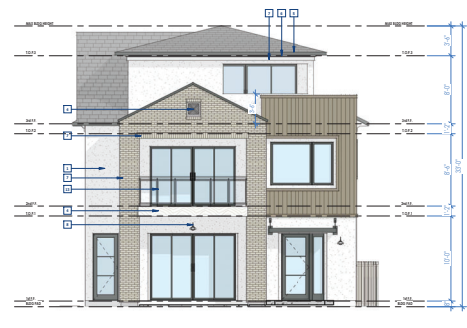

TYPE B - FRONT ELEVATION
3/16" = 1'-0" ①



TYPE B - SIDE 1 ELEVATION
3/16" = 1'-0" ④

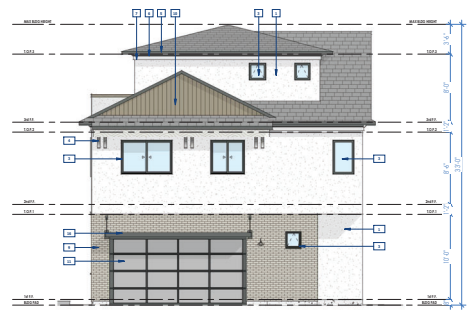

TYPE B - REAR ELEVATION
3/16" = 1'-0" ②

EXTERIOR FINISH SCHEDULE

1. CEMENT PLASTER - CRYSTAL WHITE (LA HABRA STUCCO)
 - FINISH SAND STUCCO FINISH, COLOR: X-50
2. PRECAST TRIM / PRECAST CAP / FANTASIE (LA HABRA STUCCO)
 - STUCCOED, COLOR: CRYSTAL WHITE, X-50
3. EXTERIOR WINDOWS (MIGARD WINDOWS) (SICCS180-Z)
 - COLLECTION: TUSCANY WHITE
 - COLOR: BLACK
4. WOODWORK / DECORATIVE VENT / DECORATIVE WOOD BRACKET
 - PAINTED, COLOR: DEW341 SWISS COFFEE (DUNN-EDWARDS)
5. COMPOSITE SLATE ROOF TILE (DAWING ROOFCAPE)
 - SINGLE WIND SLATE, COLOR: EUROPEAN
6. FASCIA BOARD (MILWORK BY OTHERS)
 - 2x4 FASCIA BOARD, PAINTED
 - COLOR: DEW341 SWISS COFFEE (DUNN-EDWARDS)
7. CROWN MOULDING (LA HABRA STUCCO)
 - STUCCOED, COLOR: CRYSTAL WHITE, X-50
8. EXTERIOR LIGHTING
 - COLOR: BLACK
 - DOWNWARD FACING LIGHT AT SIDE FACING
9. BRICK VENEER (EL DORADO 3D)
 - COLLECTION: EL DORADO BRICKS, TUNDRA CHALK DUST
10. VERTICAL COMPOSITE CLADDING (NEWTECHWOOD)
 - UNFINISHED CLADDING, BRICK COLOR: BRASLANI PE
11. GARAGE DOOR (AMARR GARAGE DOOR)
 - LINCOLN COLLECTION, COLOR: BLACK
12. DOWNSPOUT (LEAKHEAD) FAN GUTTER
 - COLOR COATED ALUMINUM, COLOR: BLACK
13. RAILING AT BALCONY
 - GLASS WITH BLACK IRON
14. VINYL FENCING / GATE
 - PAINTED, DEW341 SWISS COFFEE
15. STANDING SEAM METAL ROOF
 - COLOR: BLACK
16. METAL AWNING
 - COLOR: BLACK



ARCHITECTURE + DESIGN
771 S. PASEO AVE.
ARCHANA, CA 91504
TEL: 951-294-7402
WWW.PDS-STUDIO.COM



PROJECT:
**14 UNITS MULTIFAMILY
RESIDENTIALS**

304 - 202 2nd AVE
ARCHANA CA 91504

PROJECT DATE:
1/21/2024 4:24:31 PM

PROJECT NO.:
REVISION: DATE

NOTES:



CHECKED BY: Checker

DESIGNED BY: Architect

PROJECT NAME:
ELEVATIONS - TYPE B

SHEET NO.:
3.2

EXTERIOR FINISH SCHEDULE

1. CEMENT PLASTER - CRYSTAL WHITE (LA HABRA STUCCO)
 - FINISH SAND STUCCO FINISH, COLOR: X-50
2. PRECAST/CON / PRECAST CONCRETE (LA HABRA STUCCO)
 - STUCCOED, COLOR: CRYSTAL WHITE, X-50
3. EXTERIOR WINDOWS (MIGARD WINDOWS) **(SICCS180-Z)**
 - COLLECTION: TOSCANY WHITE
 - COLOR: BLACK
4. WOODWORK / DECORATIVE VENT / DECORATIVE WOOD BRACKET
 - PAINTED, COLOR: DEW341 SWISS COFFEE (DUNN-EDWARDS)
5. COMPOSITE SLATE ROOF TILE (DAVING ROOFCAPE)
 - SINGLE WINDSHIELD, COLOR: EUROPEAN
6. FASCIA BOARD (MILWORK BY OTHERS)
 - 2x4 FASCIA BOARD, PAINTED
 - COLOR: DEW341 SWISS COFFEE (DUNN-EDWARDS)
7. CROWN MOULDING (LA HABRA STUCCO)
 - STUCCOED, COLOR: CRYSTAL WHITE, X-50
8. EXTERIOR LIGHTING
 - COLOR: BLACK
 - DOWNWARD FACING LIGHT AT SIDE FACING
9. BRICK VENEER (EL DORADO 3D)
 - COLLECTION: EL DORADO BRICKS, TINDRA CHALK DUST
10. VERTICAL COMPOSITE CLADDING (NEWTECHWOOD)
 - LEARNERD CLADDING, 1/8" BRICK COLOR BRANLANI PE
11. GARAGE DOOR (AMARR GARAGE DOOR)
 - LINCOLN COLLECTION, COLOR: BLACK
12. DOWNSPOUT (LEAKHEAD) RAIN GUTTER
 - COLOR COATED ALUMINUM, COLOR: BLACK
13. RAILING AT BALCONY
 - GLASS WITH BLACK IRON
14. VINYL FENCING / GATE
 - PAINTED, DEW341 SWISS COFFEE
15. STANDING SEAM METAL ROOF
 - COLOR: BLACK
16. METAL AWNING
 - COLOR: BLACK



ARCHITECTURE + DESIGN
 771 S. FIRST AVE.
 ANCHORAGE, AL 99501
 TEL: 407-294-7422
 WWW.PDS-STUDIO.COM



PROJECT:
 14 UNITS MULTIFAMILY
 RESIDENTIALS
 314 - 201 2nd AVE
 ANCHORAGE, AL 99501

ISSUE DATE:
 1/23/2024 4:24:34 PM
 PROJECT NO.:
 REVISION: DATE

NOTES:

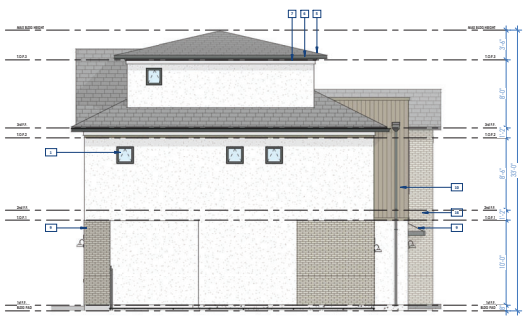

TYPE C - SIDE 1 ELEVATION
 3/16" = 1'-0" **5**



TYPE C - FRONT ELEVATION
 3/16" = 1'-0" **2**

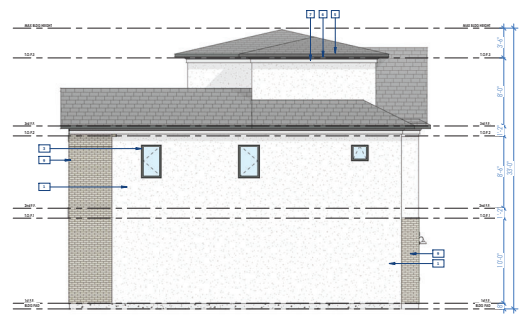

TYPE C - SIDE 2 ELEVATION
 3/16" = 1'-0" **4**



TYPE C - REAR ELEVATION
 3/16" = 1'-0" **3**

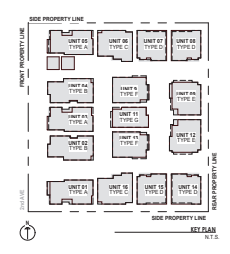

CHECKED BY: Checker
 DRAWN: Architect
 ELEVATIONS - TYPE C
 SHEET NO.:
3.3

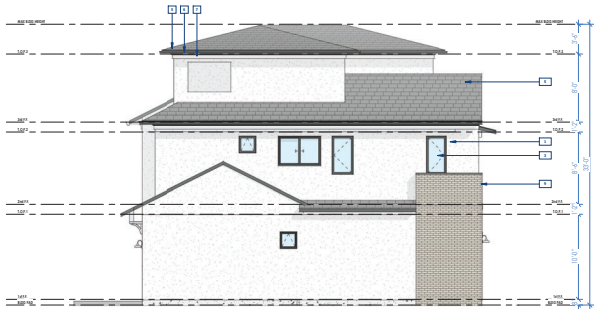

TYPE D - SIDE 2 ELEVATION
3/16" = 1'-0" ③

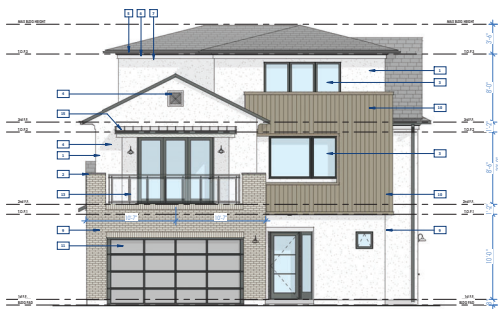

TYPE D - FRONT ELEVATION
3/16" = 1'-0" ①

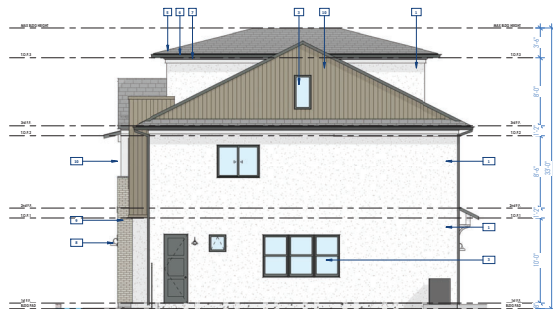

TYPE D - SIDE 1 ELEVATION
3/16" = 1'-0" ④



TYPE D - REAR ELEVATION
3/16" = 1'-0" ②

EXTERIOR FINISH SCHEDULE

1. CEMENT PLASTER - CRYSTAL WHITE (LA HABRA STUCCO)
 - FINISH SAND STUCCO FINISH, COLOR: X-50
2. PRECAST IRON / PRECAST CONCRETE (LA HABRA STUCCO)
 - STUCCOED, COLOR: CRYSTAL WHITE, X-50
3. EXTERIOR WINDOWS (MIGARD WINDOWS) (SICCS180-Z)
 - COLLECTION TOSCANI WHITE
 - COLOR: BLACK
4. WOODWORK / DECORATIVE VENT / DECORATIVE WOOD BRACKET
 - PAINTED, COLOR: DEW341 SWISS COFFEE (DUNN-EDWARDS)
5. COMPOSITE SLATE ROOF TILE (DAVING ROOFCAPE)
 - SINGLE WIND SHIELD, COLOR: EUROPEAN
6. FASCIA BOARD (MILWORK BY OTHERS)
 - 2x4 FASCIA BOARD, PAINTED
 - COLOR: DEW341 SWISS COFFEE (DUNN-EDWARDS)
7. CROWN MOULDING (LA HABRA STUCCO)
 - STUCCOED, COLOR: CRYSTAL WHITE, X-50
8. EXTERIOR LIGHTING
 - COLOR: BLACK
 - DOWNWARD FACING LIGHT AT SIDE FACING
9. BRICK VENEER (EL DORADO STONE)
 - COLLECTION EL DORADO BRICKS, TUNDRA CHALK DUST
10. VERTICAL COMPOSITE CLADDING (NEWTECHWOOD)
 - LEARNERD CLADDING, 1/8"X8" COLOR: BRALIANI PE
11. GARAGE DOOR (AMARR GARAGE DOOR)
 - UNICOPY COLLECTION, COLOR: BLACK
12. DOWNPOUT / LEAKBOARD / FAN GUTTER
 - COLOR COATED ALUMINUM, COLOR: BLACK
13. RAILING AT BALCONY
 - GLASS WITH BLACK IRON
14. VINYL FINISHING / GATE
 - PAINTED: DEW341 SWISS COFFEE
15. STANDING SEAM METAL ROOF
 - COLOR: BLACK
16. METAL AWNING
 - COLOR: BLACK



ARCHITECTURE + DESIGN

771 S. FIRST AVE.
ARCHERDALE, CA 91754
TEL: 951-214-7422
WWW.PDS-STUDIO.COM

ARCHITECT SCALE:



PROJECT:

14 UNITS MULTIFAMILY
RESIDENTIALS

314 - 201 2nd AVE
ARCHERDALE, CA 91754

PROJECT DATE:
1/21/2024 4:24:28 PM

PROJECT NO.:

REVISION: DATE:

NOTES:

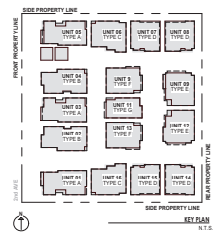

CHECKED BY: Checker

DESIGNED BY: Architect

ELEVATIONS - TYPE D

ISSUED NO.:

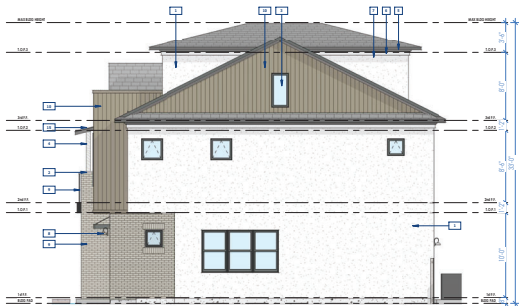

TYPE E - SIDE 2 ELEVATION
3/16" = 1'-0" 3

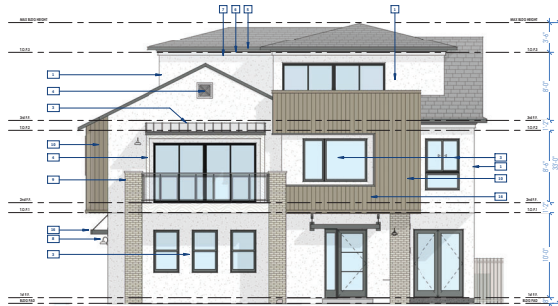

TYPE E - FRONT ELEVATION
3/16" = 1'-0" 1

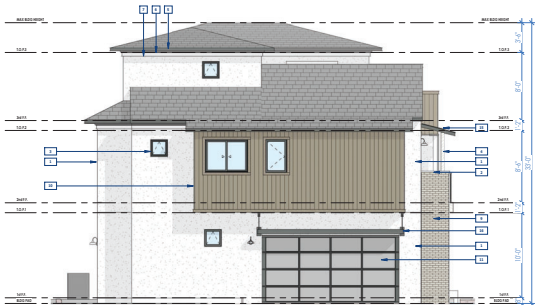

TYPE E - SIDE 1 ELEVATION
3/16" = 1'-0" 4

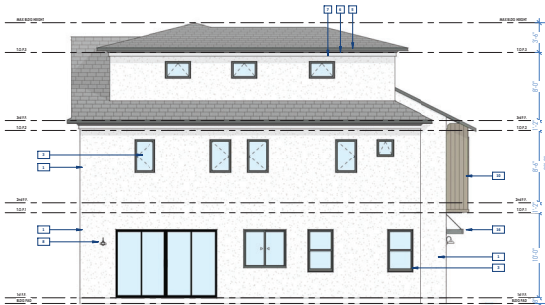

TYPE E - REAR ELEVATION
3/16" = 1'-0" 2

EXTERIOR FINISH SCHEDULE

1. CEMENT PLASTER - CRYSTAL WHITE (LA HABRA STUCCO)
 - FINISH SAND STUCCO FINISH, COLOR: X-50
2. PRECAST IRON / PRECAST CONCRETE (LA HABRA STUCCO)
 - STUCCOED, COLOR: CRYSTAL WHITE, X-50
3. EXTERIOR WINDOWS (MIGARD WINDOWS) [SICCS180-Z]
 - COLLECTION: TOSCANY WHITE
 - COLOR: BLACK
4. WOODWORK / DECORATIVE VENT / DECORATIVE WOOD BRACKET
 - PAINTED, COLOR: DEW341 SWISS COFFEE (DUNN-EDWARDS)
5. COMPOSITE SLATE ROOF TILE (DAVING ROOFCAPE)
 - SINGLE WIND SHIELD, COLOR: EUROPEAN
6. FASCIA BOARD (MILWORK BY OTHERS)
 - 2x4 FASCIA BOARD, PAINTED
 - COLOR: DEW341 SWISS COFFEE (DUNN-EDWARDS)
7. CROWN MOULDING (LA HABRA STUCCO)
 - STUCCOED, COLOR: CRYSTAL WHITE, X-50
8. EXTERIOR LIGHTING
 - COLOR: BLACK
 - DOWNWARD FACING LIGHT AT SIDE FACING
9. BRICK VENEER (EL DORADO STONE)
 - COLLECTION: EL DORADO BRICKS, TUNDRA CHALK DUST
10. VERTICAL COMPOSITE CLADDING (NEWTECHWOOD)
 - LEARNERED CLADDING, BIRCH COLOR BRALIANI PE
11. GARAGE DOOR (AMARR GARAGE DOOR)
 - LINCOLN COLLECTION, COLOR: BLACK
12. DOWNPOUT / LEAKPROOF FAN GUTTER
 - COLOR COATED ALUMINUM, COLOR: BLACK
13. RAILING AT BALCONY
 - GLASS WITH BLACK IRON
14. VINYL FENCING / GATE
 - PAINTED, DEW341 SWISS COFFEE
15. STANDING SEAM METAL ROOF
 - COLOR: BLACK
16. METAL AWNING
 - COLOR: BLACK



PDS STUDIO

ARCHITECTURE + DESIGN
771 S. FIRST AVE.
ARCHAIC, CA 94524
TEL: 925-294-7422
WWW.PDS-STUDIO.COM

ARCHITECT: ASL



PROJECT:
14 UNITS MULTIFAMILY
RESIDENTIALS

314 - 202 2nd AVE
ARCHAIC, CA 94524

PROJECT DATE:
5/23/2024 4:24:31 PM

PROJECT NO.:

REVISION: DATE:

NOTES:

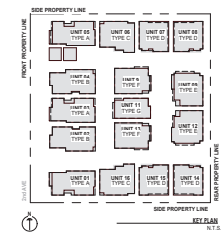

CHECKED BY: Checker

DESIGNED BY: Architect

ELEVATIONS - TYPE E

SHEET NO.:

3.5

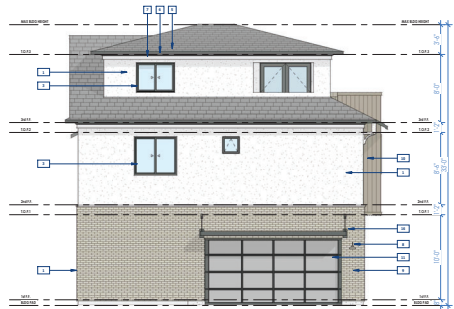

TYPE F - REAR ELEVATION
3/16" = 1'-0" ③

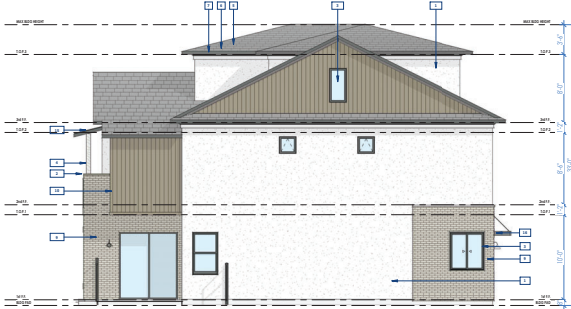

TYPE F - SIDE 2 ELEVATION
3/16" = 1'-0" ①

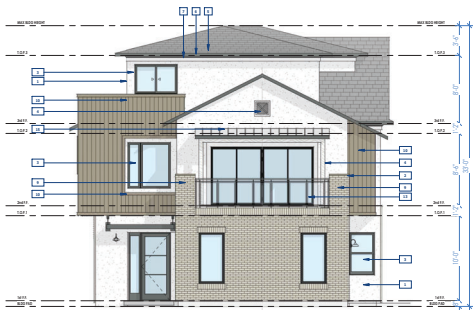

TYPE F - FRONT ELEVATION
3/16" = 1'-0" ④

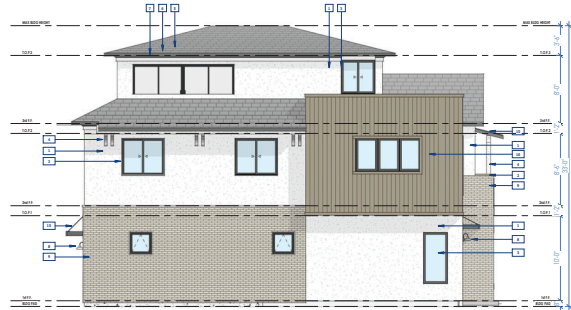

TYPE F - SIDE 1 ELEVATION
3/16" = 1'-0" ②

EXTERIOR FINISH SCHEDULE

1. CEMENT PLASTER - CRYSTAL WHITE (LA HABRA STUCCO)
 - FINISH SAND STUCCO FINISH, COLOR: X-50
2. PRECAST IRON / PRECAST CONCRETE (LA HABRA STUCCO)
 - STUCCOED, COLOR: CRYSTAL WHITE, X-50
3. EXTERIOR WINDOWS (MIGARD WINDOWS) [SICCS180-Z]
 - COLLECTION: TOSCANY WHITE
 - COLOR: BLACK
4. WOODWORK / DECORATIVE VENT / DECORATIVE WOOD BRACKET
 - PAINTED, COLOR: DEW341 SWISS COFFEE (DUNN-EDWARDS)
5. COMPOSITE SLATE ROOF TILE (DAVING ROOFCAPE)
 - SINGLE WIND-SLATE, COLOR: EUROPEAN
6. FASCIA BOARD (MILWORK BY OTHERS)
 - 2x4 FASCIA BOARD, PAINTED
 - COLOR: DEW341 SWISS COFFEE (DUNN-EDWARDS)
7. CROWN MOULDING (LA HABRA STUCCO)
 - STUCCOED, COLOR: CRYSTAL WHITE, X-50
8. EXTERIOR LIGHTING
 - COLOR: BLACK
 - DOWNWARD FACING LIGHT AT SIDE FACING
9. BRICK VENEER (EL DORADO 3D)
 - COLLECTION: EL DORADO BRICKS, TINDRA CHALK DUST
10. VERTICAL COMPOSITE CLADDING (NEWTECHWOOD)
 - UNPAINTED CLADDING, BIRCH COLOR, BRASLANI PE
11. GARAGE DOOR (AMARR GARAGE DOOR)
 - UNICOBY COLLECTION, COLOR: BLACK
12. DOWNPOUT (LEAKGUARD) FAN OUTLET
 - COLOR: COATED ALUMINUM, COLOR: BLACK
13. RAILING AT BALCONY
 - GLASS WITH BLACK IRON
14. VINYL FENCING / GATE
 - PAINTED: DEW341 SWISS COFFEE
15. STANDING SEAM METAL ROOF
 - COLOR: BLACK
16. METAL AWNING
 - COLOR: BLACK

PDS STUDIO
ARCHITECTURE + DESIGN
771 S. PASEO AVE.
ARCHANA, CA 94504
TEL: 925-294-7422
WWW.PDS-STUDIO.COM

ARCHITECT SEAL:

PROJECT:
**14 UNITS MULTIFAMILY
RESIDENTIALS**

304 - 300 2nd AVE
ARCHANA CA 94504

PROJECT DATE:
1/23/2024 4:24:34 PM

PROJECT NO. _____
REVISION _____ DATE _____

NOTES:

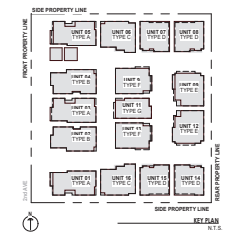

CHECKED BY: Checker
DRAWN: Architect
ELEVATIONS - TYPE F

3.6



TYPE G - SIDE 2 ELEVATION 3
3/16" = 1'-0"

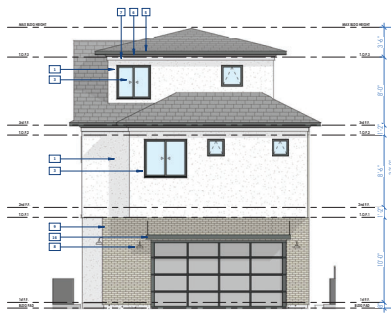

TYPE G - REAR ELEVATION 1
3/16" = 1'-0"

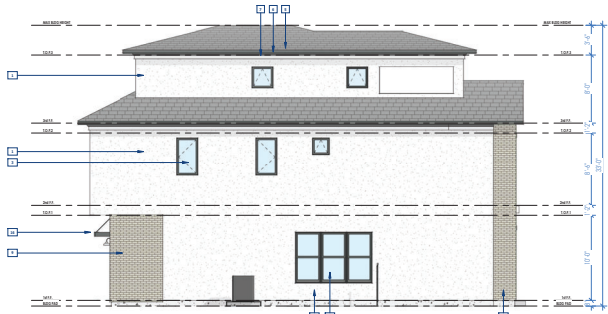

TYPE G - SIDE 1 ELEVATION 4
3/16" = 1'-0"

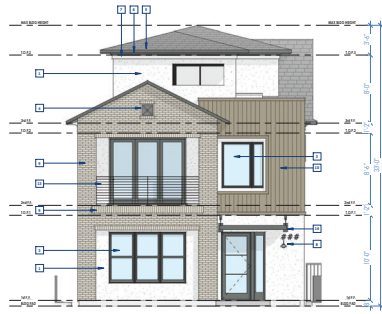

TYPE G - FRONT ELEVATION 2
3/16" = 1'-0"

EXTERIOR FINISH SCHEDULE

1. CEMENT PLASTER - CRYSTAL WHITE (LA HABRA STUCCO)
 - FINISH SAND STUCCO FINISH, COLOR: X-50
2. PRECAST CON / PRECAST CON AT PARAPET (LA HABRA STUCCO)
 - STUCCOED, COLOR: CRYSTAL WHITE, X-50
3. EXTERIOR WINDOWS (MIGARD WINDOW) [SICCS180-Z]
 - COLLECTION: TUSCANY WHITE
 - COLOR: BLACK
4. WOODWORK / DECORATIVE VENT / DECORATIVE WOOD BRACKET
 - PAINTED, COLOR: DEW341 SWISS COFFEE (DUNN-EDWARDS)
5. COMPOSITE SLATE ROOF TILE (DAWING ROOFCAPE)
 - SINGLE WIND SLATE, COLOR: EUROPEAN
6. FASCIA BOARD (MILWORK BY OTHERS)
 - 2x4 FASCIA BOARD, PAINTED
 - COLOR: DEW341 SWISS COFFEE (DUNN-EDWARDS)
7. CROWN MOULDING (LA HABRA STUCCO)
 - STUCCOED, COLOR: CRYSTAL WHITE, X-50
8. EXTERIOR LIGHTING
 - COLOR: BLACK
 - DOWNWARD FACING LIGHT AT SIDE FACING
9. BRICK VENEER (EL DORADO STONE)
 - COLLECTION: EL DORADO BRICKS, TUNDRA CHALK DUST
10. VERTICAL COMPOSITE CLADDING (NEWTECHWOOD)
 - UNFINISHED CLADDING, 1/8" x 8" COLOR: BRASLANI PE
11. GARAGE DOOR (AMARR GARAGE DOOR)
 - UNICOPY COLLECTION, COLOR: BLACK
12. DOWNROOST (LEAKSHIELD) FAN GUTTER
 - COLOR COATED ALUMINUM, COLOR: BLACK
13. RAILING AT BALCONY
 - GLASS WITH BLACK IRON
14. VINYL FENCING (GATE)
 - PAINTED, DEW341 SWISS COFFEE
15. STANDING SEAM METAL ROOF
 - COLOR: BLACK
16. METAL AWNING
 - COLOR: BLACK



PROJECT:
14 UNITS MULTIFAMILY
RESIDENTIALS
314 - 202 2nd AVE
ANCHORAGE, AL 99501

ISSUE DATE:
1/23/2024 4:24:37 PM
PROJECT NO.:
REVISION: DATE

NOTES:

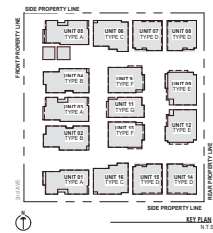

CHECKED BY: Checker
DRAWN: ArchStudio
ELEVATIONS - TYPE G
ISSUE NO.:

3.7

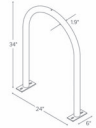

Submittal Sheet

CAPACITY: 2 Bikes

MATERIALS: 18\"/>

7 BICYCLE RACK SPECIFICATION
N.T.S.

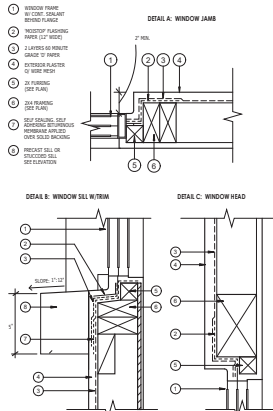

5 RECESSED WINDOW AT STUCCO WALL
N.T.S.

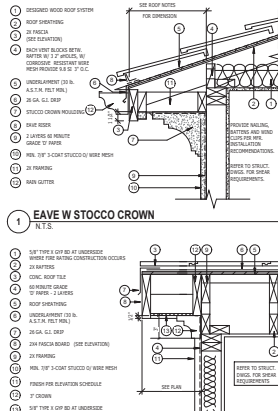

2 RAKE
N.T.S.

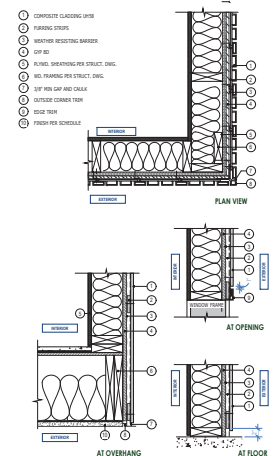

6 COMPOSITE CLADDING APPLICATION
N.T.S.

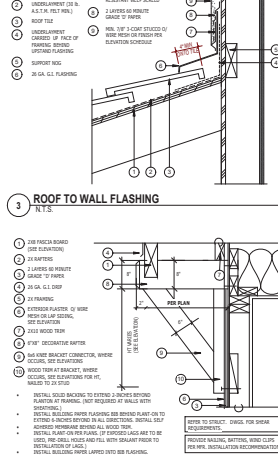

4 KNEE BRACKET SUPPORT
N.T.S.

WINDOW SCHEDULE

MARK	NO.	ABB.	WINDOW TYPE	WIDTH	HEIGHT	TG. F.T.
01	8P	AW	AWNING	2'-0"	2'-0"	
02	28	AW	AWNING	2'-6"	2'-6"	
03	3	AW	AWNING	4'-0"	3'-0"	
04	21	AW	AWNING	3'-0"	2'-0"	
05	30	CS	CASEMENT	2'-6"	4'-0"	
33	18	CS	CASEMENT	2'-6"	4'-6"	
06	6	FX	FIXED	3'-0"	5'-0"	
07	12	FX	FIXED	3'-0"	6'-0"	
08	21	FX	FIXED	3'-0"	4'-6"	
09	23	FX	FIXED	2'-6"	4'-0"	
10	3	FX	FIXED	3'-0"	2'-0"	
12	15	FX	FIXED	2'-6"	5'-0"	
13	4	FX	FIXED	4'-0"	2'-0"	
14	3	FX	FIXED	3'-0"	4'-0"	
15	16	FX	FIXED	2'-0"	4'-0"	
16	3	FX	FIXED	4'-0"	2'-0"	
19	15	FX	FIXED	3'-0"	3'-0"	
36	3	FX	FIXED	3'-6"	5'-6"	
37	3	FX	FIXED	1'-6"	3'-6"	
14	2	SH	SINGLE HUNG	2'-6"	5'-0"	
21	24	SH	SINGLE HUNG	3'-0"	5'-0"	
23	22	SH	SINGLE HUNG	3'-0"	5'-0"	
32	6	SH	SINGLE HUNG	3'-0"	8'-0"	
22	19	SL	SLIDING	5'-0"	7'-0"	
23	17	SL	SLIDING	3'-0"	4'-6"	
24	6	SL	SLIDING	4'-6"	3'-6"	
26	17	SL	SLIDING	4'-6"	7'-0"	
27	9	SL	SLIDING	4'-0"	4'-0"	
29	2	SL	SLIDING	4'-0"	4'-6"	
38	6	SL	SLIDING	5'-0"	3'-6"	

DOOR SCHEDULE

MARK	NO.	ABB.	DOOR TYPE	WIDTH	HEIGHT	NOTES
1	7	SLTG	BIFOLD PATIO	9'-0"	8'-0"	
2	1	DBL	DOUBLE DOOR	4'-0"	7'-0"	
3	13	DBL	DOUBLE DOOR	3'-0"	7'-0"	
45	2	DBL	DOUBLE DOOR	5'-0"	8'-0"	
03	4	DBL SC	DOUBLE PANEL	4'-0"	6'-8"	
6	6	DBL	DOUBLE UNVEN	4'-6"	6'-6"	
5	8	DBL	DOUBLE UNVEN	4'-6"	7'-0"	
6	12	SC	ENTRY DOOR	2'-8"	7'-0"	
6	2	ENTRY	ENTRY DOOR	3'-0"	8'-0"	
7	19	SC	ENTRY DOOR	2'-8"	8'-0"	
8	3	DBL FD	FRENCH (DBL)	5'-0"	8'-0"	
9	2	DBL FD	FRENCH (DBL)	6'-0"	8'-0"	
14	2	DBL FD	FRENCH (DBL)	8'-0"	7'-0"	
9	16	FD	FRENCH (FULL GLASS)	3'-6"	8'-0"	
11	2	FD	FRENCH (FULL GLASS)	3'-0"	8'-0"	
12	18	GD	GARAGE DR	18'-0"	8'-0"	
13	2	MEL	MEDIA CASE	2'-6"	8'-0"	
23	21	SLTG	PATIO DOORS	12'-0"	7'-0"	
24	12	SL	PATIO DOORS	12'-0"	8'-0"	
25	4	SL	PATIO DOORS	10'-0"	7'-0"	
31	2	SLTG	PATIO DOORS	12'-0"	6'-8"	
14	16	SDAT	SCREENED	1'-8"	8'-0"	
15	5	SC	SINGLE DOOR	3'-0"	7'-0"	
16	39	SC	SINGLE DOOR	2'-8"	8'-0"	
17	79	SC	SINGLE DOOR	2'-6"	7'-0"	
18	88	SC	SINGLE DOOR	2'-8"	7'-0"	
19	8	SC	SINGLE DOOR	2'-6"	8'-0"	
20	3	SC	SINGLE DOOR	2'-0"	6'-8"	
21	6	SL	SLIDING DOORS	3'-0"	7'-0"	
22	2	SL	SLIDING DOORS	8'-0"	7'-0"	
29	2	SL	SLIDING DOORS	8'-0"	8'-0"	
32	2	SL	SLIDING DOORS	7'-0"	8'-0"	

ABBREVIATIONS

AW	AWNING	DBL	DOUBLE
BD	BARN DOOR	FD	FRENCH DOOR
CLST	CLOSET	SC	SOLID CORE
CS	CASEMENT	SH	SINGLE HUNG
DBL	DOUBLE	SL	SLIDING
E	EGRESS	SLR	SLIDER
F	FRENCH DOOR	TD	TEMPERED GLASS
FD	FRENCH DOOR	TRFL	TRIPLE

DETAILS

WINDOW / DOOR SCHEDULES

PDS STUDIO
ARCHITECTURE + DESIGN
771 S. FIRST AVE.
ARCHAULA, CA 94554
TEL: 925-294-7400
WWW.PDS-STUDIO.COM

PROJECT NO. 14 UNITS MULTIFAMILY RESIDENTIALS
DATE: 1/21/2024 4:18:08 PM

DESIGNED BY: Checker
CHECKED BY: ArnieChen
SCHEDULE / DETAILS

99



3D ISOMETRIC VIEW ①



PDS STUDIO

ARCHITECTURE + DESIGN

371 S. FIRST AVE.

ARCHON, CA 91504

TEL: 651-216-1422

WWW.PDS-STUDIO.COM

ARCHITECT SEAL:



PROJECT:

14 UNITS MULTIFAMILY
RESIDENTIALS

314 - 320 2nd AVE

ARCHON, CA 91504

ISSUE DATE:

1/21/2024 4:18:30 PM

PROJECT NO.:

REVISION DATE:

NOTES:

CHECKED BY: Checker

DATE:

ISSUE NAME:

3D ISOMETRIC VIEWS

SHEET NO.:

5.0

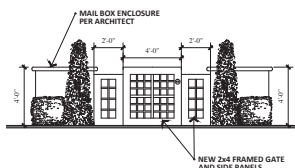

PEDESTRIAN GATE ELEVATION
SCALE: 3/8"=1'-0"

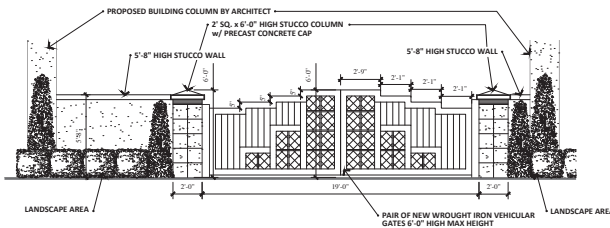

VEHICULAR GATE ELEVATION
SCALE: 3/8"=1'-0"

LEGEND:

1. NEW OR EXISTING CONCRETE DRIVEWAY ENTRY.
2. GRAY / TAN COLORED STAMPED CONCRETE OR INTERLOCKING PAVERS, PER OWNER'S CHOICE. (TYPICAL)
3. TAN COLORED WASH FINISH CONCRETE w/ 6" WIDE BANDS, SCORE AS SHOWN. (TYPICAL)
4. INDICATES IRRIGATED GROUND COVER AND MULCH; SEE PLANTING PLAN (TYPICAL)
5. UTILITY VAULT.
6. 2-3" DECORATIVE RIVER STONE OR INORGANIC GROUND COVER.
7. REAL OR SYNTHETIC TURF, PER CITY STANDARDS.
8. BOXWOOD OR PRIVET HEDGE MAINTAINED AT 3' HIGH MAX. (TYPICAL)
9. NATURAL GRAY WASH FINISHED CONCRETE, SCORE AS SHOWN. (TYPICAL)
10. MAILBOX ENCLOSURE AND PEDESTRIAN GATE PER ARCHITECT, SEE GATE ELEVATION ABOVE.
11. LIGHT COLORED (WHITE OR LIGHT GRAY) 5'-6" VINYL FENCE. (TYPICAL)
12. VINYL GATE TO MATCH FENCING (#11). (TYPICAL)
13. ENTRY GATES & PILASTERS, SEE GATE ELEVATION ABOVE.
14. 3" THICK NON-COMPACTED 3/4" CRUSHED ROCK OR PEA GRAVEL PER OWNER'S CHOICE OVER GEOFABRIC WEED BARRIER. (TYPICAL)
15. TRASH ENCLOSURE PER ARCHITECT.
16. EUGENIA COMPACTA HEDGE/SCREEN AT PERIMETER FENCEWALL.
17. NEW 6' HIGH C.M.U WALL PER ARCHITECT.
18. EXISTING 6' HIGH BRICK WALL TO REMAIN.

FRONT YARD HARDSCAPE:

TOTAL FRONT YARD SETBACK: 6,450 SQ.FT.
TOTAL FRONT YARD HARDSCAPE: 2,447 SQ.FT (37.9%)

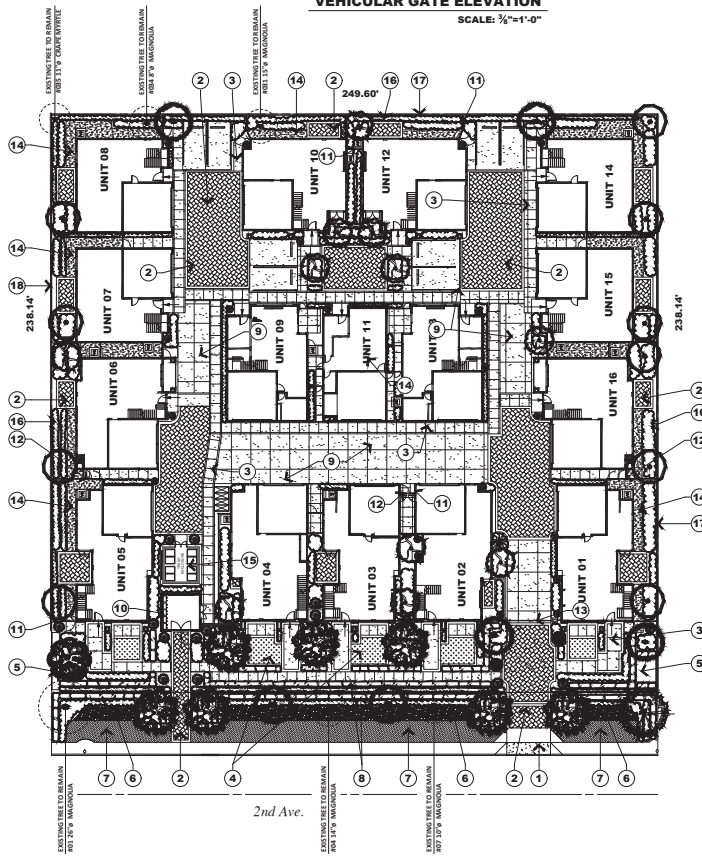

TOTAL SITE AREA: 40,869 SQ. FT.
TOTAL LANDSCAPE AREA: 13,352 SQ. FT.

ARCHITECTURE NOTE:

FOR SITE PLAN NOTES AND LOT SQ. FOOTAGE CALCULATIONS, SEE SEPARATE PLAN BY ARCHITECT:
PDS STUDIO
626-294-9402
WWW.PDS-STUDIO.COM

NOTE:

UPON APPROVAL OF THE CONCEPTUAL LANDSCAPE PLAN LAYOUT THE LANDSCAPE ARCHITECT SHALL PREPARE PLANTING AND IRRIGATION PLANS IN ACCORDANCE WITH THE WATER EFFICIENT LANDSCAPE ORDINANCE (WELO) STATE AND CITY REQUIREMENTS.

TREE PALETTE

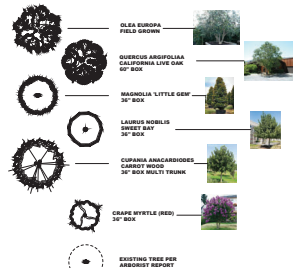

Total existing Trees on Site (includes 1 Oak Tree):	36
Total existing Trees to remain:	6
Proposed new Trees to replace existing (24\"/>	
Proposed new 15 Gal. screen Trees at rear and sides of Property:	150
Existing Oak Trees onsite to be removed:	1
Proposed new Oak Trees to replace existing to be removed:	1

SHRUB PALETTE



PROJECT: **15 UNIT RESIDENTIAL COMPLEX**
SITE: **ARCADIA, CA 91007**

LANDSHAPE, INC.
LANDSCAPE ARCHITECTURE
PLANNING
MARK A. CERAMACHI, LICENSE # 47185
04/18/21

SHEET TITLE: **CONCEPTUAL LANDSCAPE PLAN**

TITLE	DATE	BY	CHKD
DESIGNED			
DRAWN			
CHECKED			
DATE	BY	CHKD	

JOB NO. **02223**
SHEET **L1**

Attachment No. 6

Arborist Reported Dated December 9, 2023

314-326 2nd Ave Arcadia, CA 91006

Prepared for:

**Philip Chan c/o PDS Studio
711 First Ave Arcadia, CA 91006
Arcadia, CA 91006**

December 9, 2023

Prepared by:

Javier Cabral Consulting Arborist
International Society of Arborists # WE- 8116A

1390 El Sereno Ave
Pasadena, California 91103
(626)818-8704
jtcabral@sbcglobal.net

Table of contents

Arborist Certificate----- pg. 3

Background and assignment Summary ----- pg. 4

Site Conditions & Google Earth Image ----- pg. 5

List Inventory ----- pg. 6 & 7

Survey & Site Plan With Trees ----- pg. 8 & 9

Tree Pictures ----- pg. 10 thru 30

Protection Guidelines ----- pg. 31 thru 36

Certificate of performance & Disclosure Statement ----- pg. 37

Arborist Signature Page ----- Pg. 38

The International Society of Arboriculture

Hereby Announces That

Javier Cabral

Has Earned the Credential

ISA Certified Arborist ®

By successfully meeting ISA Certified Arborist certification requirements through demonstrated attainment of relevant competencies as supported by the ISA Credentialing Council



Cathy Pollihan
CEO & Executive Director

15 September 2007

Issue Date

31 December 2025

Expiration Date

WE-8116A

Certification Number



Summary

Mr. Chan,

You have retained my consulting arborist services to provide a tree inventory and protection plan for the property described as 324 – 356 2nd Ave Arcadia, CA 91006. You are in the planning and permitting process of demolishing the existing multi-family 8 units and redeveloping the property with a new multi-family 15 units.

The proposed demolition and construction is expected to have minimal impact to the protected trees that will remain due to the distance of excavations, trenches, and footings to the tree trunks. A complete tree protection plan will be included to protect above and below ground tree parts from physical damage, soil compaction, and chemical damage.

Background and assignment

Mr. Chan has requested that I provide the following arboricultural services.

- 1) Identify all significant trees and protected trees on the property and label them on the architectural drawings as provided to the arborist by Mr. Philip Chan.
- 2) Evaluate the current health of the trees and possible impacts of the proposed construction based on the provided site plan and make recommendations.
- 3) Provide a tree protection plan that will help ensure the short and long term health of the protected trees that will remain during and after construction activities are completed.

The following report is based on my site visit on December 8, 2023 and my analysis of the trees, topo, site plan, and surrounding landscape. For the purpose of this report I will address these trees as **Trees # 1 thru 36**.

Site conditions

An 8 multi-family units currently exist on this property located 324 – 356 2nd Ave Arcadia, CA 91006.

- 1) There are **(36)** total trees on the subject property of which **(4)** trees are protected by the City of Arcadia Tree Protection Ordinance due to their location and species.
- 2) There is **(1)** protected tree proposed to be removed. No off-site trees shall be impacted.

Google Earth Image



General Tree Condition Rating Guidelines (one or more of the below mentioned defects may not be present but one or more may be so extensive that it may downgrade a tree that would otherwise qualify for example, a (C) grade to a (D) grade due to the severity of the defect. As the consulting arborist I will make any annotation when the aforementioned conditions are the case so that the grade is better understood. Each tree will be rated as an individual tree with its structure, canopy, and root system.

- A)** - Healthy, vigorous tree, reasonably free of disease, with good structure and form typical of the species.
- B)** - A tree with slight decline in vigor, small amount of twig dieback, minor structural defects that could be corrected.
- C)** - A tree with moderate vigor, moderate twig and small branch dieback, thinning crown, poor leaf color, moderate structural defects that might be mitigated.
- D)** - A tree in decline, epicormics growth, extensive dieback of medium to large branches, significant structural defects that cannot be abated.
- F)** - A tree in severe decline, dieback of scaffold branches and or trunk, mostly epicormics growth, extensive structural defects that cannot be abated.

List Inventory pg. 1

Tree #	Common Name	Botanical Name	Diameter at 4 feet In inches	Height (in feet)	Spread (in feet)	Health condition rating	Protection status	REMOVE or Preserve	Comments
1	Southern magnolia	Magnolia grandiflora	30	43	37	A	YES	Preserve	
2	Mexican fan palm	Washingtonia robusta	na	na	na	na	No	Remove	
3	Crape myrtle	Laferstroemia indica	3+7+9	20	20	A	No	Remove	
4	Southern magnolia	Magnolia grandiflora	15	30	24	B	YES	Preserve	
5	Jacaranda	Jacaranda mimosifolia	2+3+7	25	18	B	No	Remove	
6	Mexican fan palm	Washingtonia robusta	na	na	na	na	No	Remove	
7	Southern magnolia	Magnolia grandiflora	4+6+6+6	18	18	D	No	Remove	Severely stressed
8	Canary island palm	Phoenix canariensis	na	na	na	na	No	Remove	
9	Canary island palm	Phoenix canariensis	na	na	na	na	No	Remove	
10	Camphor	Cinnamomum camphora	10	25	25	A	No	Remove	
11	Bottlebrush	Callistemon citrinis	2+2+3+4+4+5+5	18	16	B	No	Remove	
12	Canary island palm	Phoenix canariensis	na	na	na	na	No	Remove	
13	American sweetgum	Liquidambar styraciflua	18	60	21	B	No	Remove	
14	Mexican fan palm	Washingtonia robusta	na	na	na	na	No	Remove	

List Inventory pg. 2

Tree #	Common Name	Botanical Name	Diameter at 4 feet In inches	Height (in feet)	Spread (in feet)	Health condition rating	Protection status	REMOVE or Preserve	Comments
15	American sweetgum	Liquidambar styraciflua	15	45	21	B	No	Remove	
16	Crape myrtle	Lagerstroemia indica	17	14	13	A	No	Remove	
17	California pepper	Schinus molle	25	50	41	B	No	Remove	
18	Crape myrtle	Lagerstroemia indica	11	35	27	A	No	Remove	
19	Crape myrtle	Lagerstroemia indica	8	25	23	A	No	Remove	
20	Hollywood juniper	Juniperus chinensis	9+20	35	18	B	No	Remove	
21	Crape myrtle	Lagerstroemia indica	1+2+2+3+3+3+3+3+3+3+3+3+4+4+4	18	18	A	No	Remove	
22	California fan palm	Washingtonia filifera	na	na	na	na	No	Remove	
23	California fan palm	Washingtonia filifera	na	na	na	na	No	Remove	
24	Pecan	Carya illioinensis	20	50	33	C	No	Remove	severely topped
25	California fan palm	Washingtonia filifera	na	na	na	na	No	Remove	
26	California fan palm	Washingtonia filifera	na	na	na	na	No	Remove	
27	Queen palm	Syagrus romanzoffiana	na	na	na	na	No	Remove	
28	Avocado	Persea americana	18	18	16	D	No	Remove	Dying
29	Coast live oak	Quercus agrifolia	16	16	30	B	YES	Remove	
30	Avocado	Persea americana	14	14	18	B	No	Remove	
31	Southern magnolia	Magnolia grandiflora	15	15	16	B	YES	PRESERVE	
32	Pecan	Carya illioinensis	29	29	30	C	No	Remove	Severely topped
33	Pecan	Carya illioinensis	25	25	30	C	No	Remove	Severely topped
34	Southern magnolia	Magnolia grandiflora	8	8	16	B	No	PRESERVE	
35	Crape myrtle	Lagerstroemia indica	11	11	16	A	No	PRESERVE	
36	Mexican fan palm	Washingtonia robusta	na	na	na	na	No	Remove	

Site Survey With Trees (Full scale)

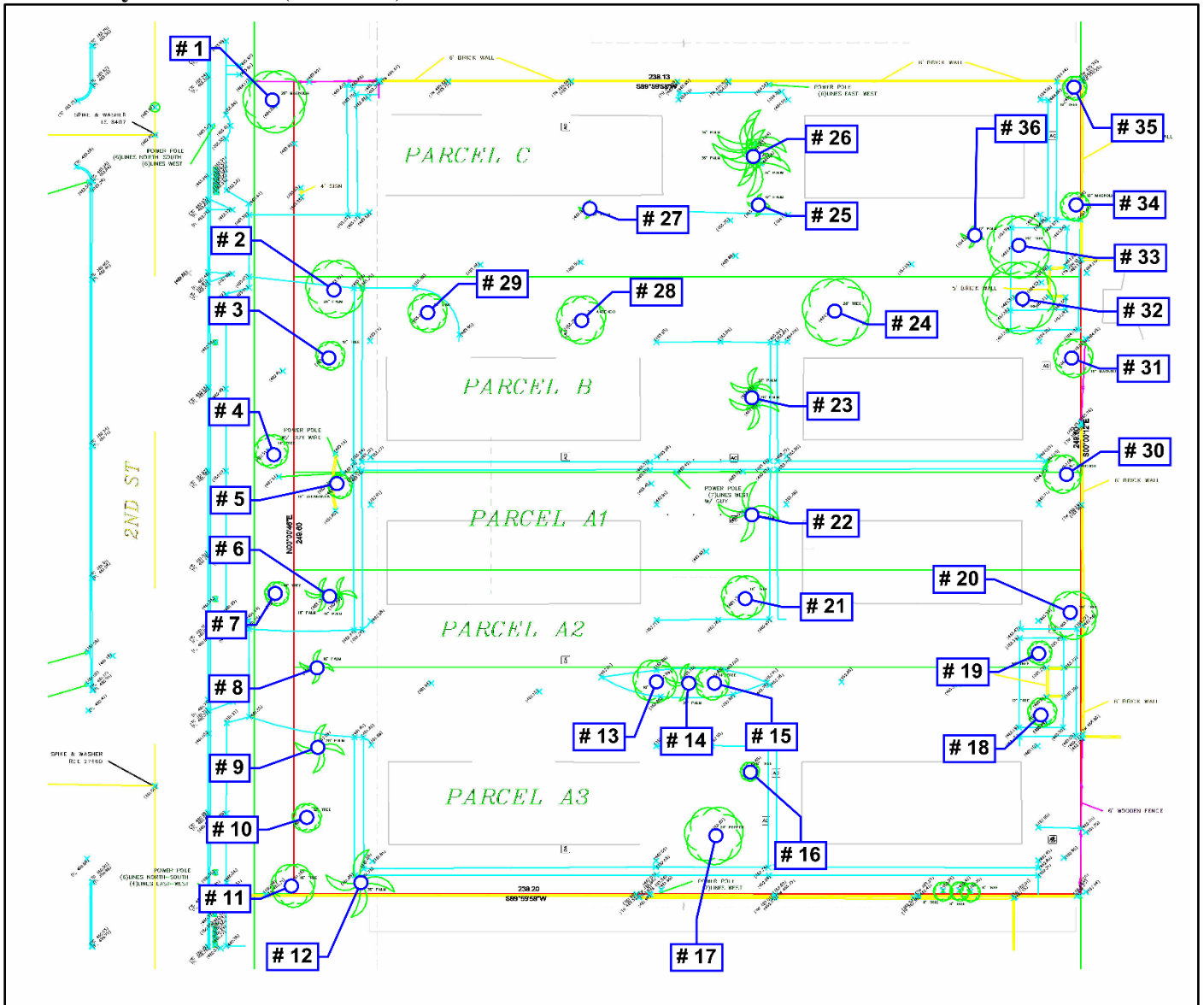

Site Plan With Protected Trees (cropped)

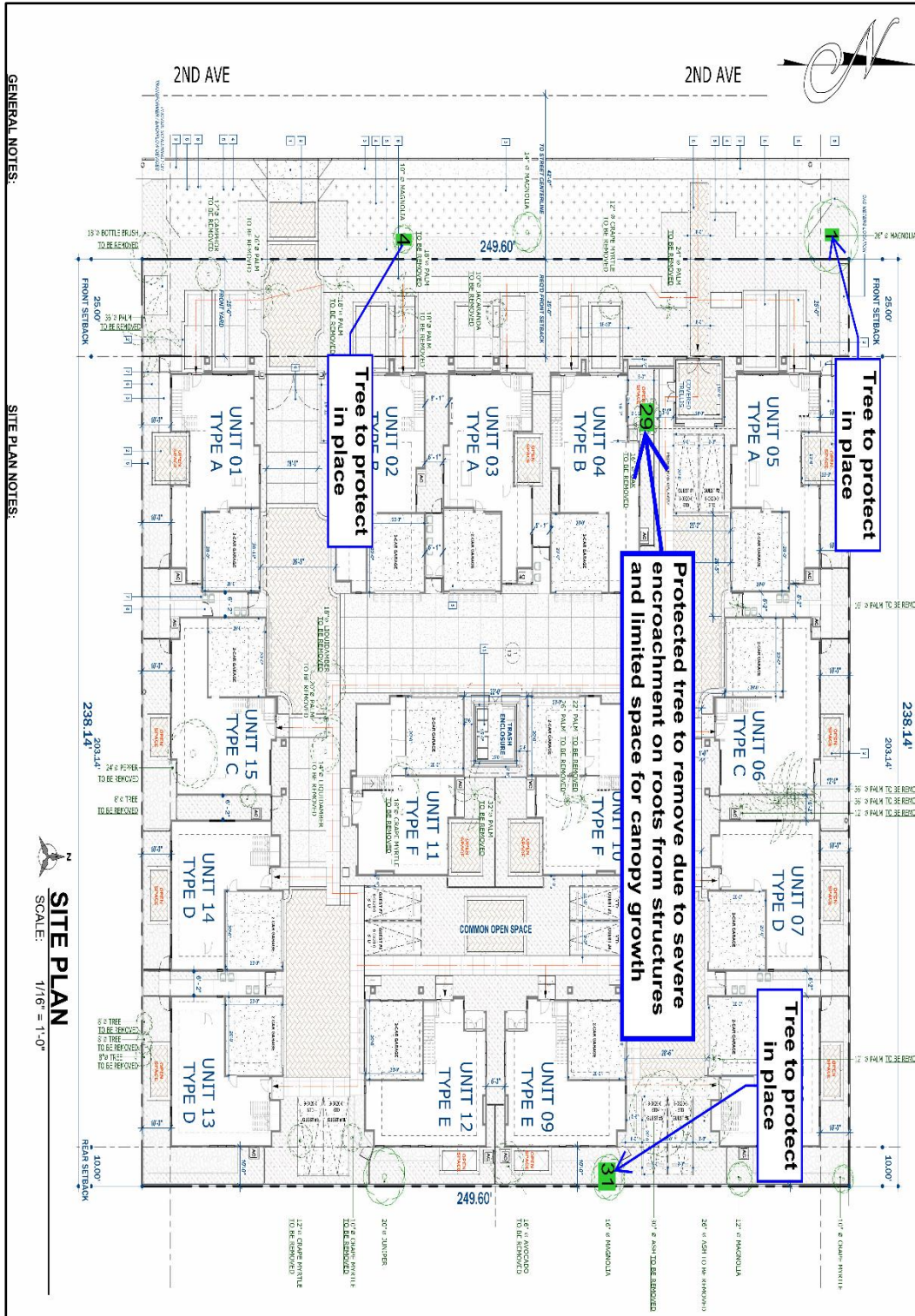

GENERAL NOTES:

SITE PLAN NOTES:

SITE PLAN
SCALE: 1/16" = 1'-0"

Trees # 1 (facing north)



Trees # 2 & 3 (facing east)



Trees # 4 & 5 (facing south)



Trees # 6 & 7 (facing south)

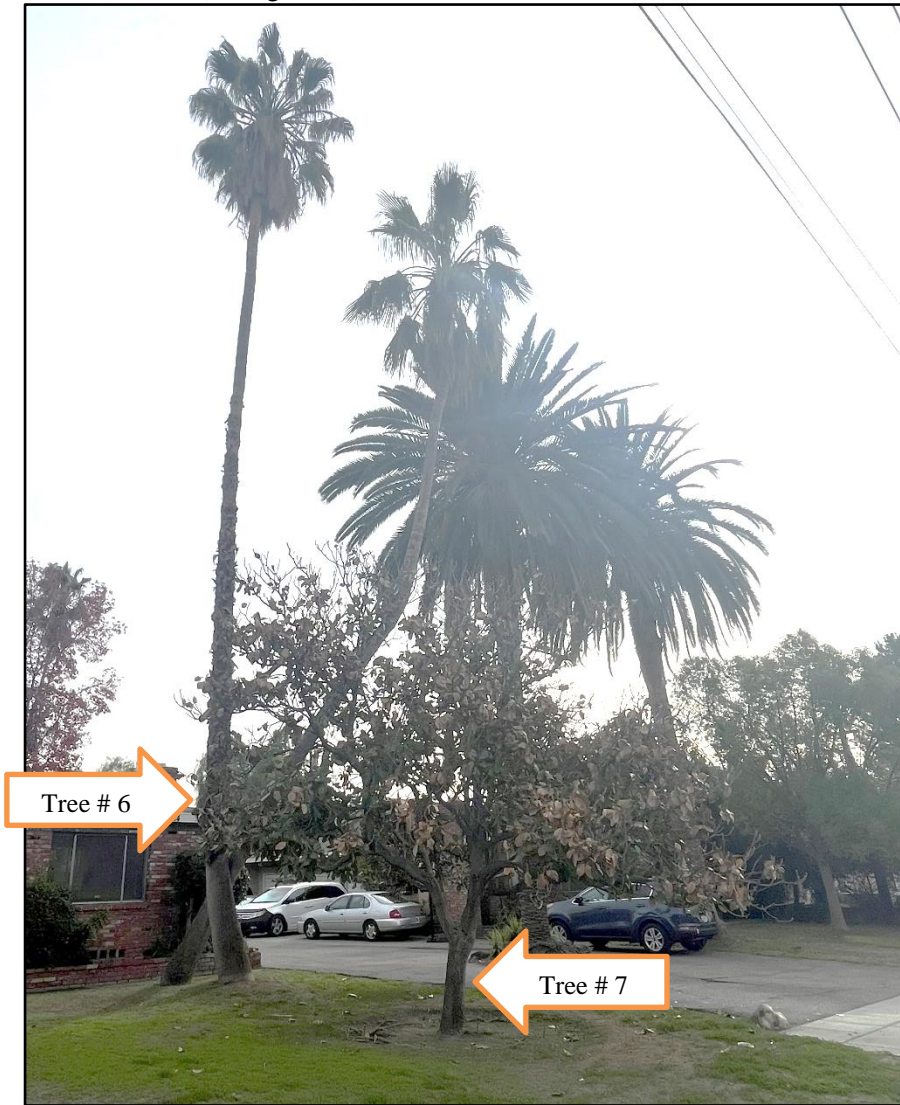

Trees # 8 & 9 (facing east)



Trees # 10 thru 12 (facing southeast)



Trees # 13 thru 15 (facing south)



Trees # 16 & 17 (facing south)



Trees # 18 thru 20 (facing east)



Trees 21 thru 23 (facing north)



Tree # 24 (facing east)



Trees # 25 & 26 (facing north)



Tree 27 (facing northeast)



Tree 28 (facing southeast)



Tree 29 (facing southwest)



Tree 30 (facing south)



Tree 31 (facing southeast)



Trees 32 & 33 (facing east)



Tree 34 (facing north)



Tree 35 (facing south)



Tree 36 (facing east)



General Tree Protection Plan

- 1) **Avoid damaging the roots, stem, and branches** with mechanical and manual equipment. No roots shall be severed within the Tree Protection Zone “TPZ” which is the same as the area within the Tree Protection Fencing “TPF.” Roots greater than two inches in diameter outside of the TPZ shall be cleanly severed with a sharp tool such as a hand saw or manual pruners.
- 2) **Avoid soil compaction** by prohibiting the use of heavy equipment such as backhoes and bobcats under the tree drip line. If access within the TPZ is required during the construction process, the route shall be covered in a 6 inch layer of mulch in the TPZ and the area shall be aerated and fertilized at the conclusion of construction.
- 3) **Do not store or park tools**, equipment, vehicles, or chemicals under the tree drip line. No equipment or debris of any kind shall be placed within the TPZ. No fuel, paint, solvent oil, thinner, asphalt, cement, grout, or any other construction chemical shall be stored or allowed in any manner to enter within the TPZ.
- 4) **Avoid washing of equipment** and tools such as wheel barrels, shovels, and mechanical motors under the tree drip line.
- 5) **Prevent flooding and pooling** of service water under the drip line. Grade changes that will flood the TPZ are prohibited unless a drainage plan is implemented. No grade changes within the TPZ shall be allowed.
- 6) **Avoid cutting tree roots whenever possible**. This can sometimes be accomplished by bridging roots, tunneling, or radial trenching. If roots must be cut use a sharp tool that will make a clean flush cut and not tear the roots. If possible all digging under the tree drip line should be done manually to avoid tearing out of roots. Roots outside of the TPZ may be cleanly severed vertically with a sharp garden tool.
- 7) **Do not raise or lower the grade** within the tree protection zone of any protected trees unless approved by the project arborist. Roots greater than 1 inch in diameter that are exposed or damaged shall be cut with a sharp tool such as a hand saw, pruners, or loppers and covered with soil in conformance to industry standards as soon as possible. If any work is required within the TPZ the Arborist shall be consulted previous to beginning. The Arborist shall be contacted as soon as possible to arrange for a timely inspection and prevent delays.

- 8) Protection fencing shall be 5 to 6 ft. high chain link freestanding panels or secured to posts driven into the ground. There shall be no entry gates into the protected zones. **The protection fencing shall be in place before demolition begins and shall only be removed or reduced when all heavy equipment such as back-hoes, bobcats, loaders, and other heavy equipment with tires and tracks will not be required.** Fencing can be adjusted or sections reduced or removed as the project advances into the landscaping phases of the project. The consulting arborist shall be contacted if there are doubts about the placement or removal of fencing.

- 9) **Landscape preparation & excavation within the TPZ** shall be limited to the use of hand tools and small hand-held power tools and shall not be of a depth that could cause root damage. No attachments or wires other than those of a protective or non-damaging method shall be attached to a protected tree.

- 10) **Construction personnel should be briefed** on the importance of the guidelines before construction begins and reminded of it during tailgate meetings and as necessary. A printed copy should be posted where employees can be reminded of it.

Survey With Protection Fencing (cropped)

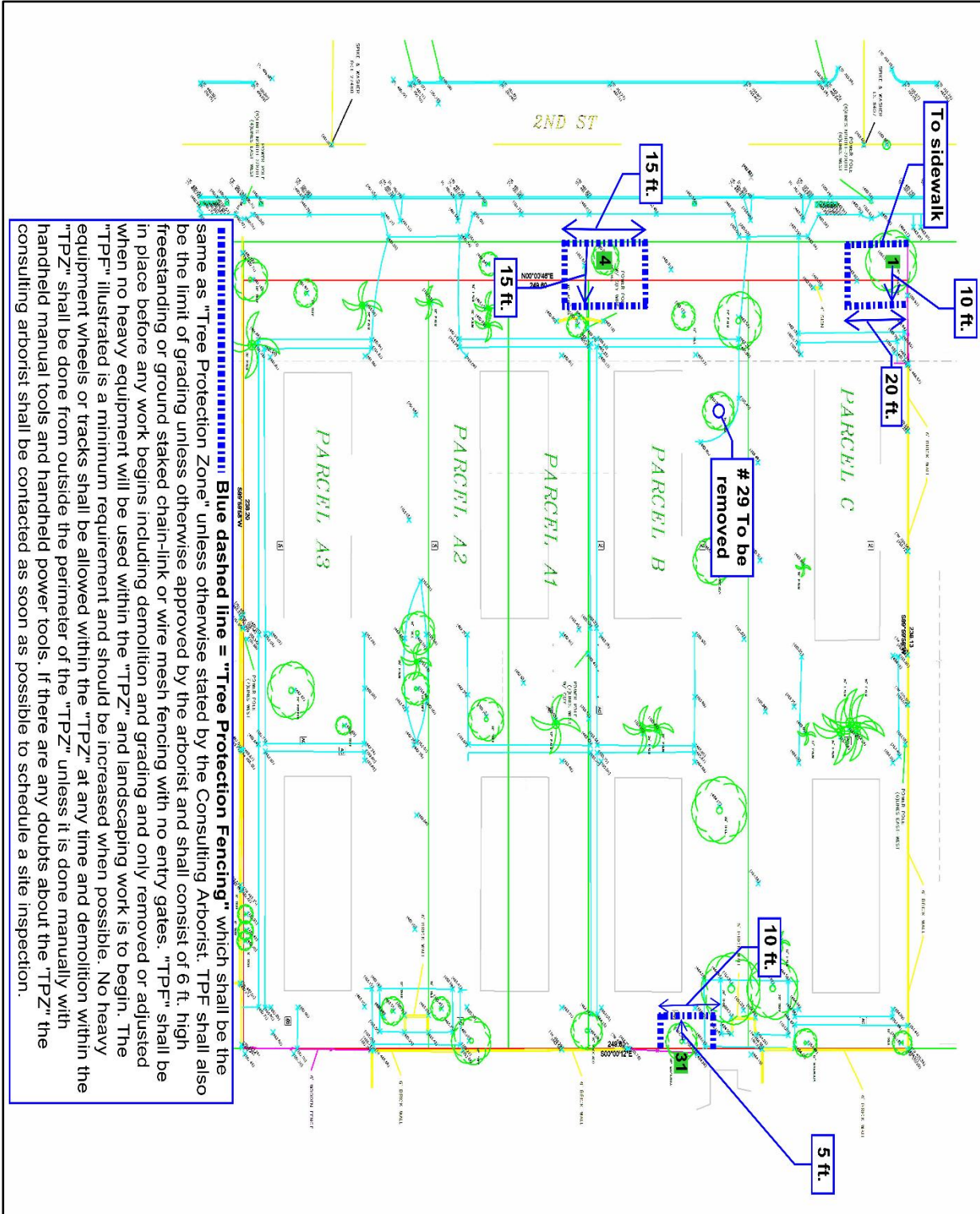

Tree # 1 Southern magnolia (Protection Details)

- a) **Structural excavation and over-excavation:** No structural excavations are proposed within the drip line of this tree . Impact is expected to be zero.
- b) **New driveway:** The new driveway is proposed on the opposite side of the property. Impact is expected to be zero.
- c) **New Landscaping:** The removal of the existing grass and under the drip line of this tree shall be done manually with manual tools to a maximum depth of 3 inches to prevent severe root disturbance and damage.
- d) **New Sprinklers:** No broadcast trenching for sprinklers shall be performed within 5 ft. of the edge of the tree trunk on all sides of this tree. The sprinkler water shall not wet the trunk of this tree to prevent fungal infection from persistent trunk moisture.
- e) **Canopy pruning:** No pruning of this tree will be required to complete the proposed construction project.
- f) **Root pruning:** Roots within 10 ft. from the trunk that are encountered for plantings shall be relocated if a root greater than 2 inches is encountered.
- g) **Protection Fencing:** shall consist of 6 ft. high chain link free standing panels and shall be in place before any works begins including demolition. All protection fencing may be removed or reduced when all heavy equipment and major construction is completed and landscaping is ready to be installed.
- h) **Maintenance:** During the hot summer months this tree shall be watered as needed until the sprinkler system is installed and working.
- i) **Encroachment impacts:** *This project is expected to have a minimal to zero impact* on the short- or long-term health of this tree and it is expected to survive in good health if the protection recommendations are followed and adhered to. minimal impact means that no roots greater than two inches are expected to be impacted and no interruption to water uptake or nutrient production, transportation, or storage is expected. Tree stability, anchorage, trunk, branch, and leaves are not expected to be impacted.

Tree # 4 Southern magnolia (Protection Details)

- a) **Structural excavation and over-excavation:** No structural excavations are proposed within the drip line of this tree . Impact is expected to be zero.
- b) **New driveway:** The new driveway is proposed on the opposite side of the property. Impact is expected to be zero.
- c) **New Landscaping:** The removal of the existing plants and ground cover under the drip line of this tree shall be done manually with manual tools only to prevent severe root disturbance and damage.
- d) **New Sprinklers:** No broadcast trenching for sprinklers shall be performed within 5 ft. of the edge of the tree trunk on all sides of this tree. The sprinkler water shall not wet the trunk of this tree to prevent fungal infection from persistent trunk moisture.
- e) **Canopy pruning:** No pruning of this tree will be required to complete the proposed construction project.
- f) **Root pruning:** Roots within 10 ft. from the trunk that are encountered for plantings shall be relocated if a root greater than 2 inches is encountered.
- g) **Protection Fencing:** shall consist of 6 ft. high chain-link free-standing panels and shall be in place before any works begins including demolition. All protection fencing may be removed or reduced when all heavy equipment and major construction is completed, and landscaping is ready to be installed.
- h) **Maintenance:** During the hot summer months this tree shall be watered as needed until the sprinkler system is installed and working.
- i) **Encroachment impacts:** *This project is expected to have a minimal to zero impact* on the short- or long-term health of this tree and it is expected to survive in good health if the protection recommendations are followed and adhered to. *minimal impact means* that no roots greater than two inches are expected to be impacted and no interruption to water uptake or nutrient production, transportation, or storage is expected. Tree stability, anchorage, trunk, branch, and leaves are not expected to be impacted.

Tree # 31 Southern magnolia (Protection Details)

- a) **Structural excavation and over-excavation:** No structural excavations are proposed within the drip line of this tree . Impact is expected to be zero.
- b) **New driveway:** The new driveway is proposed on the opposite side of the property. Impact is expected to be zero.
- c) **New Landscaping:** The removal of the existing plants and ground cover under the drip line of this tree shall be done manually with manual tools only to prevent severe root disturbance and damage.
- d) **New Sprinklers:** No broadcast trenching for sprinklers shall be performed within 5 ft. of the edge of the tree trunk on all sides of this tree. The sprinkler water shall not wet the trunk of this tree to prevent fungal infection from persistent trunk moisture.
- e) **Canopy pruning:** No pruning of this tree will be required to complete the proposed construction project.
- f) **Root pruning:** Roots within 10 ft. from the trunk that are encountered for plantings shall be relocated if a root greater than 2 inches is encountered.
- g) **Protection Fencing:** shall consist of 6 ft. high chain-link free-standing panels and shall be in place before any works begins including demolition. All protection fencing may be removed or reduced when all heavy equipment and major construction is completed, and landscaping is ready to be installed.
- h) **Maintenance:** During the hot summer months this tree shall be watered as needed until the sprinkler system is installed and working.
- i) **Encroachment impacts:** *This project is expected to have a minimal to zero impact* on the short- or long-term health of this tree and it is expected to survive in good health if the protection recommendations are followed and adhered to. *minimal impact means* that no roots greater than two inches are expected to be impacted and no interruption to water uptake or nutrient production, transportation, or storage is expected. Tree stability, anchorage, trunk, branch, and leaves are not expected to be impacted.

Certificate of Performance & Limiting Conditions

I Javier Cabral certify the following:

- No warranty is made, expressed or implied, that problems or deficiencies of the trees or the property will not occur in the future, from any cause. The Arborist shall not be responsible for damages or injuries caused by any tree defects, and assume no responsibility for the correction of defects or tree related problems.
- The owner and client of the trees may choose to accept or disregard the recommendations of the Arborist or seek additional advice if the owner decides not to accept the Arborists findings or recommendations.
- The Arborist has no past, present or future interest in the removal or preservation of any tree. The opinions contained in the Arborist report are independent and objective judgements of the Arborist.
- The findings, opinions, and recommendations of the Arborist are based on based on the physical inspection of said property. The opinions are based on knowledge, experience, and education.
- The Arborist shall not be required to provide testimony, provide site monitoring, provide further documentation for changes beyond the control of the Arborist, be deposed, or to attend any meeting without contractual arrangements for additional fees to the Arborist.
- The Arborist assumes no responsibility for verification of ownership or location of property lines, or for any recommendations based on inaccurate information.
- This Arborist report may not be reproduced without the expressed written permission of the Arborist and the client to whom the report was provided to. Any changes or alteration of this report invalidates the entire report.
- Arborists are tree specialists who use their education, knowledge, training and experience to examine trees, recommend measures to enhance the beauty and health of trees, make recommendations to prevent or minimize damage to trees during and after construction projects, and attempt to reduce the risk of living near trees. Clients may choose to accept or disregard the recommendations of the arborist, or to seek additional advice.
- Arborists cannot detect every condition that could possibly lead to the structural failure of a tree. Trees are living organisms that fail in ways we do not fully understand. Conditions are often hidden within trees and below ground. Arborists cannot guarantee that a tree will be healthy or safe under all circumstances, or for a specified period of time. Likewise, remedial treatments, like any medicine, cannot be guaranteed.
- Treatment, pruning and removal of trees may involve considerations beyond the scope of the arborist's services such as property boundaries, property ownership, site lines, disputes between neighbors, and other issues. Arborists cannot take such considerations into account unless complete and accurate information is disclosed to the arborist. An arborist should then be expected to reasonably rely upon the completeness and accuracy of the information provided.
- Trees can be managed, but they cannot be controlled. To live near trees is to accept some degree of risk. The only way to eliminate all risk associated with trees is to eliminate all trees.

Thank you and feel free to contact me if you have any questions or concerns.

Yours truly,

Javier Cabral / Consulting arborist
1390 El Sereno Ave Pasadena, Ca 91103
International Society of Arboriculture # WE 8116A

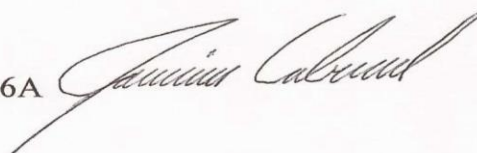
A handwritten signature in black ink that reads "Javier Cabral". The signature is written in a cursive style with a long, sweeping underline that extends to the right.

Attachment No. 7

Letter from Property Owner at 319 S.
Second Avenue

to whom it may concern:

3/12/24

We don't approve on the multi-family residential development, we think they are destroying our good neighbor by building skyscraper (that's what it would look like) It will also bring more traffic on Second which we don't need more. We will have a harder time to get out of our driveway on 319 and that is this only way to back up out of our driveway.

Do you think you want to buy a house with that much traffic?? I don't think so. So the price will go down no matter when we decide to sell. It's a shame they want to remove some protected trees that been there for years (ever). It's beautiful to look at them, should not be destroyed. Arcadia should stay a beautiful city.

Think about all the inconvenience for all of us. Hope you hear us and think of people of Second Avenue

Thank you, 319 E. Second Avenue

Doris & Jon Arbour

Attachment No. 8

Preliminary Exemption Assessment



CITY OF
ARCADIA

PRELIMINARY EXEMPTION ASSESSMENT

1. Name or description of project:	Multiple Family Architectural Design Review No. MFADR 23-03, Tentative Tract Map No. TTM 23-05 (84291), Healthy Tree Removal No. TRH 23-04, and Protected Tree Encroachment No. TRE 23-10 – A tentative tract map for a 16-unit residential condominium detached townhome development	
2. Project Location – Identify street address and cross streets or attach a map showing project site (preferably a USGS 15' or 7 1/2' topographical map identified by quadrangle name):	314-326 S. 2 nd Avenue (between California Street and El Dorado Avenue)	
3. Entity or person undertaking project:	A.	
	B. Other (Private)	
	(1) Name	Philip Chan on behalf of Smart Property II LLC, property owner
	(2) Address	711 S. First Avenue
4. Staff Determination:	<p>The Lead Agency's Staff, having undertaken and completed a preliminary review of this project in accordance with the Lead Agency's "Local Guidelines for Implementing the California Environmental Quality Act (CEQA)" has concluded that this project does not require further environmental assessment because:</p>	
a. <input type="checkbox"/>	The proposed action does not constitute a project under CEQA.	
b. <input type="checkbox"/>	The project is a Ministerial Project.	
c. <input type="checkbox"/>	The project is an Emergency Project.	
d. <input type="checkbox"/>	The project constitutes a feasibility or planning study.	
e. <input checked="" type="checkbox"/>	The project is categorically exempt.	
	Applicable Exemption Class:	15332 – Class 32 (Infill Development)
f. <input type="checkbox"/>	The project is statutorily exempt.	
	Applicable Exemption:	
g. <input type="checkbox"/>	The project is otherwise exempt on the following basis:	
h. <input type="checkbox"/>	The project involves another public agency which constitutes the Lead Agency.	
	Name of Lead Agency:	

Date: January 20, 2024

Staff: Alison MacCarley, Assistant Planner



STAFF REPORT

Police Department

DATE: May 7, 2024

TO: Honorable Mayor and City Council

FROM: Roy Nakamura, Chief of Police
By: Amber Abeyta, Management Analyst

SUBJECT: ANNUAL MILITARY EQUIPMENT REPORT PER ASSEMBLY BILL NO. 481
CEQA: Not a Project
Recommendation: Approve

SUMMARY

On April 19, 2022, the City Council adopted Ordinance No. 2387 approving a Military Equipment Use Policy (“Policy”) pursuant to Assembly Bill 481 (“AB 481”). In accordance with AB 481 and the Policy, an annual report must be submitted to the City Council for any approved military equipment. The report must be submitted within one year of equipment acquisition, and annually thereafter, for as long as the military equipment is available for use. In compliance with AB 481, outlined below is the 2023 Annual Military Equipment Report and attached is the Policy.

It is recommended that the City Council approve the Annual Military Equipment Report per Assembly Bill No. 481.

BACKGROUND

On September 30, 2021, Assembly Bill 481 (“AB 481”) required law enforcement agencies to adopt a military equipment use policy (“Policy”), by ordinance, no later than May 1, 2022. The Police Department complied with AB 481 and adopted Ordinance No. 2387, approving the Policy.

AB 481 also requires law enforcement agencies to submit to the City Council an annual military equipment report (“Report”) on the use of the equipment, any complaint(s) or concern(s) regarding the use of the equipment, results of any internal audits on the use of the equipment, the annual costs for the equipment, the quantity possessed by the agency and the intent to purchase additional equipment in the following year. In addition, within 30-days of submitting and publicly releasing the Report, a well-publicized community meeting must be held to allow for public comments.

DISCUSSION

To meet the requirements of the Report pursuant to AB 481, a review was conducted of the Police Department’s military equipment with the findings reported below:

Military Equipment Use, Amount of Usage, and Annual Cost

Item	Military Equipment Use	Amount of Usage	Annual Cost
Robot	Field deployment	2	\$1,000
40MM Launcher	Training	65	\$2,750 (rounds and maintenance)
Launching Cup	Training	5	\$500 (munitions)
Distraction Device	a) Training b) Field deployment	a) 30 b) 0	\$1,200
Rifles	Training	40	\$500
Chemical Agent/Smoke	Training	15	\$1,500
Explosive Breaching Tools	N/A	0	\$0
Pepperball	Training	25	\$1,000 (round/co2)
Mobile Command Post	Field deployment	15	\$11,000 (maintenance/fuel)
Rescue Vehicle	a) Training b) Field deployment	a) 10 b) 15	\$4,000 (maintenance/fuel)
Kinetic Breaching Tool	a) Training b) Field deployment	a) 10 b) 2	\$2,500
Handgun Ammunition	Training	70,000 rounds	\$65,000
Rifle Ammunition (.223)	Training	15,000 rounds	\$25,000
Rifle Ammunition (.308)	Training	4,000 rounds	\$10,000

No new military equipment acquisitions occurred in the 2023 calendar year, resulting in no alterations in the Policy.

Complaints or Concerns

Staff reviewed department records and determined there were no complaints or concerns reported on the use of the equipment in 2023.

Internal Audit

The Department conducted an internal audit and determined that there were no violations of the military equipment use policy.

Intention to Purchase Additional Equipment

In the Fiscal Year 2024-25 Budget, the Department is seeking approval to procure an Unmanned Aerial Vehicle (“UAV”) system, commonly known as a “drone.” Drones are instrumental in enhancing response times to calls, aiding in the investigation of criminal activities, and providing aerial perspectives that can assist in protecting life and property. Additionally, drones enable personnel to assess and address issues effectively by determining suitable tools, tactics, and resources even before officers reach the scene. If the budget request to acquire a drone is approved as part of the Fiscal Year 2024-25 budget, it will undergo review by the City Council and will be documented in the annual report for that fiscal year.

In compliance with the requirements of AB 481, this staff report, which includes the Annual Report and the updated Policy, were published on the Department’s website as of April 1, 2024, which meets the required 30-day publishing period. In addition, a Public Hearing Notice was posted ten days prior to this meeting per Resolution No. 7483.

ENVIRONMENTAL ANALYSIS

The proposed action does not constitute a project under the California Environmental Quality Act (“CEQA”), and it can be seen with certainty that it will have no impact on the environment.

FISCAL IMPACT

There is no fiscal impact related to approving this annual report.

RECOMMENDATION

It is recommended that the City Council determine that this action does not constitute a project under California Environmental Quality Act (“CEQA”); and approve the Annual Military Equipment Report per Assembly Bill 481.

Approved:



Dominic Lazzaretto
City Manager

Attachment: Military Equipment Use Policy

Arcadia Police Department

Arcadia PD Policy Manual

Military Equipment

MILITARY EQUIPMENT

708.1 PURPOSE AND SCOPE

The purpose of this policy (“Policy”) is to provide guidelines for the approval, acquisition, and reporting requirements of military equipment pursuant to Assembly Bill 481 (“AB 481”). (California Government Code section 7070 et seq.)

708.1.1 DEFINITIONS

Definitions related to this Policy include those provided in Government Code Section 7070, and as follows:

Governing body — City of Arcadia City Council (“City Council”).

Military equipment — Includes but is not limited to the following:

- Unmanned, remotely piloted, powered aerial or ground vehicles.
- Mine-resistant ambush-protected (“MRAP”) vehicles or armored personnel carriers.
- High mobility multipurpose wheeled vehicles (“HMMWV”), two-and-one-half-ton trucks, five-ton trucks, or wheeled vehicles that have a breaching or entry apparatus attached.
- Tracked armored vehicles that provide ballistic protection to their occupants.
- Command and control vehicles that are either built or modified to facilitate the operational control and direction of public safety units.
- Weaponized aircraft, vessels, or vehicles of any kind.
- Battering rams, slugs, and breaching apparatuses that are explosive in nature. This does not include a handheld, one-person ram.
- Firearms and ammunition of .50 caliber or greater, excluding standard-issue shotguns and standard-issue shotgun ammunition.
- Specialized firearms and ammunition of less than .50 caliber, including firearms and accessories identified as assault weapons in Penal Code Section 30510 and Penal Code Section 30515, with the exception of standard-issue firearms.
- Any firearm or firearm accessory that is designed to launch explosive projectiles.
- Noise-flash diversionary devices and explosive breaching tools.
- Munitions containing tear gas or OC, excluding standard, service-issued handheld pepper spray.
- TASER® Shockwave, microwave weapons, water cannons, and long-range acoustic devices (“LRADs”).

- Kinetic energy weapons and munitions.
- Any other equipment as determined by City Council or a state agency to require additional oversight.

708.2 POLICY

It is the Policy of the City of Arcadia (“City”) that members of the Arcadia Police Department (“Department”) comply with the provisions of AB 481 with respect to the funding, acquisition and use of military equipment.

708.3 MILITARY EQUIPMENT COORDINATOR

The Chief of Police shall designate a member of the Department to act as the Military Equipment Coordinator. The responsibilities of the Military Equipment Coordinator include but are not limited to:

- (a) Acting as liaison to the City Council for matters related to the requirements of this Policy.
- (b) Identifying Department equipment that qualifies as military equipment in the current possession of the Department, or the equipment the Department intends to acquire that requires approval by City Council.
- (c) Conducting an inventory of all military equipment at least annually.
- (d) Collaborating with any allied agency that may use military equipment within the jurisdiction of the Department.
- (e) Preparing for, scheduling, and coordinating the annual community engagement meeting to include:
 - 1. Publicizing the details of the meeting; and
 - 2. Preparing for public questions regarding the Department’s funding, acquisition, and use of military equipment.
- (f) Preparing the annual military equipment report for submission to the Chief of Police and City Council and ensuring that the report is made available on the Department website.
- (g) Establishing the procedure for a person to register a complaint or concern, or how that person may submit a question about the use of a type of military equipment, and how the Department will respond in a timely manner.

708.4 MILITARY EQUIPMENT INVENTORY

The following constitutes a list of qualifying equipment for the Department:

708.4.1 ROBOT

An unmanned machine operating on the ground utilized to enhance the safety of the community and officers.

- (a) Description, quantity, capabilities, and purchase cost:

Item No. 1

1. Description: The Robotex Avatar III (“Avatar III”) is a remote controlled, tracked, unmanned device used to surveil an area or building before officers enter it.
 2. Quantity: One (1).
 3. Capabilities: The Avatar III is equipped with a camera that provides a real time view of its surroundings, it has a two-way communication system that allows officers to communicate with subjects/suspects remotely, and an articulating arm that allows it to open doors and move objects.
 4. Purchase Cost: The Avatar III was purchased in 2019 for \$46,000.
- (b) Purpose: The Avatar III enhances the capabilities of officers in tactical situations by allowing them to inspect dangerous situations and communicate with the subjects/ suspects from a safe distance quickly and safely.
- (c) Authorized Use: Only officers who have completed training shall be permitted to operate the robot. Deployment of the robot will be authorized by the Incident or Tactical Commander.
- (d) Expected Life Span: 8-10 years.
- (e) Fiscal Impact: Annual maintenance and battery replacement cost is approximately \$200.
- (f) Training: All robot operators must complete three (3) hours of training provided by the S.W.A.T. team.
- (g) Legal and Procedural Rules: The Avatar III will only be deployed with the authorization of the Incident or Tactical Commander and will only be deployed for official law enforcement purposes. in a manner that respects the privacy of our community and complies with State and Federal Law.

708.4.2 MM LAUNCHERS AND ROUNDS

40MM Launchers are utilized by Department personnel as a less lethal tool to launch impact rounds.

- (a) Description, quantity, capabilities, and purchase cost:

Item No. 1

1. Description: Defense Technology. 40MM Exact Impact Sponge.

2. Quantity: 520.
3. Capabilities: A less lethal 40MM lightweight plastic and foam projectile fired from a single shot 40MM launcher with a rifled barrel at 325 FPS. The 30-gram foam projectile delivers 120 ft/lbs of energy upon impact. The 40MM Exact Impact Sponge Round provides accurate and effective performance when fired from the approved distance of not less than five (5) feet and as far as 125 feet from the target.
4. Purchase Cost: \$18 each.

Item No. 2

1. Description: Defense Technology, 40MM Direct Impact OC.
2. Quantity: 140.
3. Capabilities: A less lethal 40MM lightweight plastic foam projectile fired from a single shot 40MM launcher with a rifled barrel at 295 FPS. The 39-gram foam projectile delivers 120 ft/lbs of energy upon impact in addition to the dispersion of 5 grams of OC irritant. The 40MM Direct Impact OC Round provides accurate and effective performance when deployed from the approved distance of not less than five (5) feet and as far as 120 feet from the target.
4. Purchase Cost: \$30 each.

Item No. 3

1. Description: Defense Technology, Ferret 40MM Liquid Barricade Penetrator Round.
2. Quantity: 76.
3. Capabilities: A less lethal 40MM round used to penetrate barriers, such as windows, hollow core doors, wallboard, and thin plywood. Upon impacting the barrier, the nose cone ruptures and instantaneously delivers a small amount of chemical agent inside of a structure or vehicle. In a tactical deployment situation, the 40MM Ferret is primarily used to dislodge barricaded subjects from confined areas. Its purpose is to minimize the risks to all parties through temporary discomfort and/or incapacitation of potentially violent or dangerous subjects.
4. Purchase Cost: \$23 each.

Item No. 4

1. Description: Defense Technology, 40MM Round Muzzle Blast with C5.

2. Quantity: 22.
 3. Capabilities: The 40MM Muzzle Blast OC Round is a less lethal option for the immediate and close deployment of chemical agent. It can also be employed in tactical operations such as barricaded subjects for area denial, area contamination, and a means of contaminating crawl spaces and attics. It can be deployed inside or outside and has a maximum effective range of 30 feet.
 4. Purchase Cost: \$28 each.
- (b) Purpose: To limit the escalation of conflict and to decrease the potential use of lethal force.
 - (c) Authorized Use: Examples of situations where less lethal weapon systems may include but are not limited to: Dangerous and/or combative individuals, barricaded suspects, and aggressive animals.
 - (d) Expected Life Span: 15 years.
 - (e) Fiscal Impact: Annual maintenance is approximately \$10 for each launcher.
 - (f) Training: Sworn members utilizing 40MM less lethal chemical agents or impact rounds are trained in their use by P.O.S.T. certified less lethal and chemical agent instructors.
 - (g) Legal and Procedural Use: Officers will deploy 40MM impact and chemical agents in compliance with Arcadia Police Manual section 300 and in compliance with State and Federal Law regarding the use of force.

708.4.3 COMBINED SYSTEMS LC5 40MM LAUNCHING CUP

The combined systems LC5 40MM launching cups are cups that attach to 12-gauge less lethal shotguns which allow officers to launch canisters of chemical agents or smoke.

- (a) Description, quantity, capabilities, and purchase cost:

Item No. 1

1. Description: Combined Systems LC5 40MM Launching Cup.
2. Quantity: Two (2),
3. Capabilities: The cups can be attached to a 12-gauge shotgun and the munition is launched with a model 2800 launching cartridge.
4. Purchase Cost: \$150 each.

- (b) Purpose: To deploy chemical agents into an area or location from a distance.
- (c) Authorized Use: Situations for use of the less lethal weapon systems may include but are not limited to dangerous and/or combative individuals. Riot/crowd control and civil unrest incidents. Circumstances where a tactical advantage can be obtained by the use of chemical agent, and potentially vicious animals.
- (d) Expected Lifespan: 25 years.
- (e) Fiscal Impact: No annual maintenance.
- (f) Training: Sworn members utilizing LC5 40MM launching cups are trained in their use by P.O.S.T. certified less lethal and chemical agent instructors.
- (g) Legal and Procedural Use: Only fully trained S.W.A.T. Operators will deploy LC5 40MM Launching Cup, in compliance with Arcadia Police Manual section 300 and in compliance with State and Federal Law regarding the use of force.

708.4.4 DISTRACTION DEVICE

A distraction device is used to distract dangerous suspects during assaults, hostage rescue, room entry or other high-risk arrest situations.

- (a) Description, quantity, capabilities, and purchase cost:

Item No. 1

- 1. Description: Defense Technologies Low Roll DD.
- 2. Quantity: 12.
- 3. Capabilities: A non-bursting, non-fragmenting single use device that produces a loud sound and bright light. Ideal for distracting dangerous suspects during assaults, hostage rescue, room entry or other high-risk arrest situations.
- 4. Cost: \$50 each.

Item No. 2

- 1. Description: ALS1208 Bore Thunder.
- 2. Quantity: 12.
- 3. Capabilities: The ALS1208 Bore Thunder is a 12-gauge barrel delivered light and sound distraction device that produces approximately 174 dB at five (5) feet. Because the Bore Thunder remains in the delivery device, the potential for accidental fire or unintended injury is drastically reduced.

4. Purchase Cost: \$6.80 each.
- (b) Purpose: To produce brilliant light and loud sound to momentarily distract a suspect or subject (6-8 seconds), to enhance the officers' ability to safely contact and detain or arrest.
- (c) Authorized Use: Diversionary devices shall only be used by S.W.A.T. Operators who have been trained in their proper use during hostage and barricaded subject situations, high-risk warrant (search/arrest) services where there may be extreme hazards to officers, or during other high-risk situations where their use would enhance officer and community safety.
- (d) Expected Lifespan: Until used.
- (e) Fiscal Impact: No annual maintenance.
- (f) Training: Prior to use, S.W.A.T. Operators must attend diversionary device training that is conducted by P.O.S.T. certified instructors.
- (g) Legal and Procedural Rules Use: The Department will only utilize diversion devices for official law enforcement purposes, pursuant to State and Federal law regarding the use of force.

708.4.5 RIFLES

Firearms that are fired from the from the shoulder, having a long spiral grooved barrel to make bullets spin and thereby have greater accuracy over a long distance.

- (a) Description, quantity, capabilities, and purchase cost:

Item No. 1

1. Description: Colt M4 Commando.223 carbine converted from fully automatic to semi-automatic.
2. Quantity: 92.
3. Capabilities: To provide precision fire to address a threat with more accuracy than a handgun, particularly at greater distances.
4. Purchase Cost: \$750 each.

Item No. 2

1. Description: Geissele Super Duty Rifle .223 carbine semi-automatic.

2. Quantity: 18.
3. Capabilities: To provide precision fire to address a threat with more accuracy than a handgun, particularly at greater distances.
4. Purchase Cost: \$1,750 each.

Item No. 3

1. Description: Peer LE Gold Dot.223 Rem 55 grain ammunition.
2. Quantity: 120,000 rounds.
3. Purchase Cost: \$600 per 1,000 rounds.

Item No. 4

1. Description: Black Hills.308 STX Copper 168 grain STX ammunition.
2. Quantity: 1,000 rounds.
3. Purchase Cost: \$2,300.

Item No. 5

1. Description: Colt Automatic Rifle (AR) .223.
 2. Quantity: 1
 3. Purchase Cost: \$1,400.00.
- (b) Purpose: To be used as precision weapons to address a threat with more accuracy than a handgun, particularly at greater distances. The AR is an area denial and material destruction weapon.
- (c) Authorized Use: Only members who have completed P.O.S.T. certified training are authorized to deploy a rifle.
- (d) Expected Lifespan: 10 years.
- (e) Fiscal Impact: Annual maintenance is approximately \$50 for each rifle.
- (f) Training: Prior to using a rifle, Officers must be certified by a P.O.S.T. instructor in the operation of the rifle. Additionally, all members that operate the rifle are required to train with it a minimum of three (3) times a year and must pass an annual range qualification.

- (g) Legal and Procedural Rules Use: Officers will deploy patrol rifles and the AR in accordance with Department manual section 312.3.1, and pursuant to State and Federal law regarding the use of force.

708.4.6 CHEMICAL AGENT AND SMOKE CANISTERS

Canisters that contain chemical agents that are released when deployed.

- (a) Description, quantity, capabilities, and purchase cost:

Item No. 1

1. Description: Defense Technology, Triple-Chase Separating Canister, CS.
2. Quantity: 50
3. Capabilities: The Triple-Chase CS consists of three separate canisters pressed together with separating charges between each. When deployed, the canisters separate and land approximately 20 feet apart allowing increased area coverage in a short period of time. This canister can be hand thrown or launched from a fired delivery system. The canister is 6.5 in. by 2.7 in. and holds approximately 3.2 oz. of active agent. It has an approximate dispersion time of 20-30 seconds.
4. Purchase Cost: \$47 each.

Item No. 2

1. Description: Defense Technology, Riot Control Continuous Discharge Grenade.
2. Quantity: Eight (8).
3. Capabilities: The Riot Control CS Grenade is designed specifically for outdoor use in crowd control situations with a high-volume continuous dispersion that expels its contents in approximately 20-40 seconds through four ports located on the top of the canister. This canister can be used to conceal tactical movement or to route a crowd. This launchable canister is 6.0 in. by 2.35 in. and holds approximately 2.7 oz. of active agent.
4. Purchase Cost: \$27 each.

Item No. 3

1. Description: Defense Technology, Flameless Expulsion OC Grenade.
2. Quantity: 18.

3. Capabilities: The OC Flameless Expulsion Grenade is a compact, non-pyrotechnic, chemical agent device that provides safe expulsion without risk of fire. It is safe to use inside of a residence. Unlike pyrotechnic canisters, this device's contents are expelled upon actuation of a CO₂ cartridge that will affect a confined area of approximately 1500 square feet. The canister is 7.5 in. by 1.65 in. and delivers approximately .02 oz. of active agent during its 3-second discharge time.
 4. Purchase Cost: \$49 each.
- (b) Purpose: To deescalate a situation and lower the likelihood of lethal force. Situations for use of the less lethal weapon systems may include, but are not limited to, dangerous and/or combative individuals, riot/crowd control and civil unrest incidents, circumstances where a tactical advantage can be obtained, and potentially vicious animals.
 - (c) Authorized Use: Only officers who have received P.O.S.T. certification in the use of chemical agents are authorized to use them.
 - (d) Training: Sworn members utilizing chemical agent canisters must be certified by P.O.S.T. less lethal and chemical agent instructors.
 - (e) Fiscal Impact: No annual maintenance.
 - (f) Legal and Procedural Rules: Officers will only deploy chemical agents in compliance with Department manual section 300, and State and Federal law, including those regarding the use of force.

708.4.7 EXPLOSIVE BREACHING TOOLS

Explosive breaching tools are tools that are used to conduct an explosive breach to create an entry or exit point during a tactical situation.

- (a) Description, quantity, capabilities, and purchase cost:

Item No. 1

1. Description: Detonating Cord.
2. Quantity: 80 feet.
3. Capabilities: The detonating cord is a thin, flexible plastic tube usually filled with pentaerythritol tetranitrate (PETN, pentrite). With the PETN exploding at a rate of approximately 6400 m/s, any common length of detonation cord appears to explode instantaneously. It is a highspeed fuse which explodes, rather than burns, and is suitable for detonating explosives.
4. Purchase Cost: \$1 per foot.

Item No. 2

1. Description: Nonel Detonators.
2. Quantity: 12.
3. Capabilities: A detonator is a small sensitive primary explosive device generally used to detonate a larger, less sensitive secondary explosive, such as plastic explosive.
4. Purchase Cost: \$12 each.

Item No. 3

1. Description: Royal Remington 870 Express Breaching Shotgun:
2. Quantity: Two (2).
3. Capabilities: This device allows for breachers to safely utilize shotgun breaching rounds in order to destroy deadbolts, locks, and hinges. The stand-off that is attached to the end of the barrel allows for positive placement of the device into the correct position and vents gases to prevent overpressure. This device can also defeat windows and sliding glass doors. This device uses a less lethal 2.4-inch shotgun round firing a ballistic fiber bag filled with 40 grams of lead shot, at a velocity of 270-290 feet per second (FPS).
4. Purchase Cost: \$658 each.

708.4.8 PEPPERBALL LAUNCHER

A device that discharges irritant projectiles.

- (a) Description, quantity, capabilities, and purchase cost:

Item No. 1

1. Description: PepperBall VKS Carbine.
2. Quantity: Five (5).
3. Capabilities: The Variable Kinetic System (VKS) is a compressed-air powered launcher designed to fire non-lethal PepperBall projectiles. The PepperBall VKS Carbine features a dual feed system that offers the ability to quickly switch between Hopper mode and Magazine mode for optimum versatility.
4. Purchase Cost: \$600 each.

Item No. 2

1. Description: PepperBall Live-X Projectile.
 2. Quantity: 500.
 3. Capabilities: The Live Projectile contains a concentrated amount of PAVA pepper powder. One round of LIVE-X contains the equivalent to 10 standard PepperBall rounds. Discharged from a PepperBall Launcher, the projectile has a velocity of 280-350 FPS. The projectile has a direct impact of 60 feet and an area of saturation of 150+ feet. The projectile contains 5% PAVA powder.
 4. Purchase Cost: \$3 per projectile.
- (b) Purpose: To deescalate a situation and lower the potential for the use of lethal force. Situations for use of the less lethal weapon systems may include, but are not limited to, dangerous and/or combative individuals, riot/crowd control and civil unrest incidents, circumstances where a tactical advantage can be obtained, and potentially vicious animals.
- (c) Authorized Use: Only those officers who have been trained in the use of PepperBall launchers are authorized to use them.
- (d) Expected Lifespan: Launcher and munitions: Five (5) years.
- (e) Fiscal Impact: Annual maintenance is approximately \$50 for each PepperBall launcher.
- (f) Training: Sworn members utilizing PepperBall launchers and projectiles are trained in their use by P.O.S.T. certified less lethal and chemical agent instructors.
- (g) Legal and Procedural Rules: Officers will deploy the PepperBall launcher in compliance with Department Manual Section 300, and to State and Federal law, including those regarding the use of force.

708.4.9 MOBILE COMMAND POST VEHICLE (M.C.P.)

The Mobile Command Post (M.C.P.) vehicle is a mobile office that provides shelter, access to Department computer systems, communications, food, and restroom facilities on extended events.

- (a) Description, quantity, capabilities, and purchase cost:

Item No. 1

1. Description: Freightliner Chassis (custom built) vehicle.
2. Quantity: One (1).

3. Capabilities: The M.C.P. can also be utilized for S.W.A.T./C.N.T. and other critical incidents, preplanned large events, searching for missing persons, natural disasters, and community events.
 4. Purchase Cost: \$280,000.
- (b) Purpose: To be used based on the specific circumstances of a given critical incident, large event, natural disaster, or community event that is taking place.
 - (c) Authorized Use: The M.C.P. shall be used by officers trained in their deployment and in a manner consistent with Department policy and training. Furthermore, only personnel who have completed the Department's driving and operations training will be allowed to drive the M.C.P. (Per S.O.P.).
 - (d) Expected Lifespan: The M.C.P., 20-year lifespan on chassis and vehicle structure. Upgrades as needed to ensure updated and properly maintained I.T. systems.
 - (e) Fiscal Impact: Annual maintenance is approximately \$11,000.
 - (f) Training: The driver/operator shall receive training in the safe handling of the vehicle on a closed training course. Once the operator has shown competence in vehicle handling, the driver/operator will drive the vehicle throughout the city with an experienced driver. Driver/operators will also receive training in the proper set-up and break down of the M.C.P. when deployed for events and operations.
 - (g) Legal and Procedural Rules: It is the policy of the Department to use the M.C.P. only for official law enforcement purposes, and in the accordance with California State law, City & Department Policies, and Standard Operating Procedures ("S.O.P.") related to the operation of emergency motor vehicles.

708.4.10 ARMORED RESCUE VEHICLE (A.R.V.)

The 2022 BearCat Armored Rescue Vehicle is an emergency vehicle that provides armored protection for heightened emergency responses.

- (a) Description, quantity, capabilities, and purchase cost:

Item No. 1

1. Description: Ford 550, 4WD, diesel engine, single rear wheel configuration. The vehicle is painted green with police logos. The A.R.V. provides ballistic protection for its occupants. The A.R.V. is equipped with emergency lights/siren and a public address system.
2. Quantity: One (1).
3. Capabilities: The A.R.V. can also be utilized for S.W.A.T./C.N.T. and other critical incidents, preplanned large events, natural disasters, and community events.

4. Purchase Cost: \$386,400.05.
- (b) Purpose: The A.R.V.'s primary use is to provide ballistic protection for citizens and officers during critical incidents. The A.R.V. can transport officers to and from critical incidents, assist with citizen and officer rescues, and assist with the evacuation and protection of civilians in harm's way during a critical incident.
- (c) Authorized Use: The A.R.V. shall be used by officers trained in their deployment and in a manner consistent with Department policy and training. Furthermore, only personnel who have completed the Department's driving and operations training will be allowed to drive the A.R.V.
- (d) Expected Lifespan: The ARV has a 20-25 year lifespan.
- (e) Fiscal Impact: Annual maintenance is approximately \$1,000.
- (f) Training: The A.R.V. may be used by personnel who have been properly trained in the safe handling and care of the vehicle.
- (g) Legal and Procedural Rules: It is the policy of the Department to use the A.R.V. only for official law enforcement purposes, and in the accordance with California State law, City & Department Policies, and Standard Operating Procedures ("S.O.P.") related to the operation of emergency motor vehicles.

708.4.11

KINETIC BREACHING TOOL

Kinetic Breaching Tools are powder actuated breaching tools that are used to create an entry or exit point during heightened emergency responses.

- (a) Description, quantity, capabilities, and purchase cost:

Item No. 1

1. Description: The Kinetic Breaching Tool is a specialized tool used to gain entry into structure.
 2. Quantity: Three (3)
 3. Capabilities: The Kinetic Breaching Tool utilizes a proprietary blank cartridge to deliver up to 850 ft./lbs. of kinetic energy through a steel ram, at the point of entry.
 4. Purchase Cost: \$9,650 each.
- (b) Purpose: To quickly and safely gain entry into a structure.
 - (c) Authorized Use: Kinetic Breaching Tool may only occur after notification to a supervisor, to breach entry into a structure.

- (d) Fiscal Impact: Annual maintenance is approximately \$500.
- (e) Training: Only officers trained in the use of the Kinetic Breaching Tool are authorized to use it.
- (f) Legal and Procedural Rules: Only fully trained officers are authorized to use the Kinetic Breaching Tool and only with authorization of a supervisor.

708.5

APPROVAL

The Chief of Police or the authorized designee shall obtain approval from City Council by way of an ordinance adopting this Policy. As part of the approval process, the Chief of Police or the authorized designee shall ensure the Policy is submitted to City Council and is available on the Department website at least thirty (30) days prior to any public hearing concerning the Policy. The Policy must be approved by City Council prior to engaging in any of the following:

- (a) Requesting military equipment made available pursuant to USC section 2576(a).
- (b) Seeking funds for military equipment, including but not limited to applying for a grant, soliciting, or accepting private, local, state, or federal funds, in-kind donations, or other donations or transfers.
- (c) Acquiring military equipment either permanently or temporarily, including by borrowing or leasing.
- (d) Collaborating with another law enforcement agency in the deployment or other use of military equipment within the Department's jurisdiction.
- (e) Using any new or existing military equipment for a purpose, in a manner, or by a person not previously approved by this Policy.
- (f) Soliciting or responding to a proposal for, or entering into an agreement with, any other person or entity to seek funds for, apply to receive, acquire, use, or collaborate in the use of military equipment.
- (g) Acquiring military equipment through any means not provided above.

708.6

COMPLIANCE

- (a) Department members are bound to adhere to this Policy, in addition to state and local laws and ordinances when employing the use of military equipment at any time. Violations of the law or this Policy may result in criminal or administrative investigations and, or actions.
- (b) Members of the public may register complaints or submit questions or concerns about the use of each type of military equipment in this Policy by any of the following means:

1. Via email: ArcadiaPolice@ArcadiaCa.gov
2. Via telephone: (626) 574-5156
3. Via mail: Arcadia Police Department
Attn: Military Equipment Use Coordinator
250 W. Huntington Drive
Arcadia, CA 91007

The Department is committed to responding to complaints, concerns, and questions received through any of the above methods in a timely manner.

708.7 COORDINATION WITH OTHER JURISDICTIONS

Military equipment used by any member of this jurisdiction shall be approved for use and in accordance with this Department policy. Military equipment used by other jurisdictions that are providing mutual aid to this jurisdiction, or otherwise engaged in law enforcement operations in this jurisdiction, shall comply with their respective military equipment use policies in rendering mutual aid.

708.8 ANNUAL REPORT

Upon approval of this Policy, the Chief of Police or the authorized designee should submit a military equipment report to City Council for each type of military equipment approved within one year of approval, and annually thereafter for as long as the military equipment is available for use.

The Chief of Police or the authorized designee should also make each annual military equipment report publicly available on the Department's website for as long as the military equipment is available for use. The report shall include all information required by Government Code section 7072 for the preceding calendar year for each type of military equipment in Department inventory. "Type" of military equipment is defined to mean each item that shares the same manufacturer model number.

708.9 COMMUNITY ENGAGEMENT

Within thirty (30) days of submitting and publicly releasing the annual report, the Department shall hold at least one well-publicized and conveniently located community engagement meeting, at which the Department should discuss the report and respond to public questions regarding the funding, acquisition, or use of military equipment.

**ARCADIA CITY COUNCIL
SPECIAL MEETING MINUTES
THURSDAY, APRIL 11, 2024**

CALL TO ORDER – Mayor Verlato called the Special Meeting to order at 6:32 p.m.

ROLL CALL OF CITY COUNCIL MEMBERS

PRESENT: Cheng, Kwan, Wang, Cao, and Verlato

ABSENT: None

PUBLIC COMMENTS – No one appeared.

CLOSED SESSION

a. Pursuant to Government Code Section 54956.9 (d)(1) to confer with legal counsel regarding the matter of Aldo Perez v. City of Arcadia.

b. Confer with legal counsel regarding anticipated litigation.

Significant exposure to litigation pursuant to Government Code Section 54956.9(d)(2)

Facts and Circumstances: Written threat of litigation (Government Code Section 54956.9(e)(3)) Unknown to Potential Plaintiffs.

c. Pursuant to Government Code Section 54957.6 to confer with labor negotiators.

City Negotiators: City Manager Dominic Lazzaretto, Assistant City Manager/Development Services Director Jason Kruckeberg, Interim Administrative Services Director Henry Chen, and Interim Human Resources Director Anely Williams.

Employee Organizations: Arcadia Public Works Employees Association, Arcadia City Employees Association, Arcadia Police Civilian Employees Association, Arcadia Police Officers' Association, Arcadia Firefighters' Association, and unrepresented employees: Department Heads, Division Managers, Supervisors, and part-time employees.

The Special Meeting ended at 8:50 p.m.

No reportable action was taken.



Linda Rodriguez
Assistant City Clerk

**ARCADIA CITY COUNCIL
REGULAR MEETING MINUTES
TUESDAY, APRIL 16, 2024**

1. **CALL TO ORDER** – Mayor Verlato called the Regular Meeting to order at 7:06 p.m.
2. **INVOCATION** – Reverend Darwin Ng, Arcadia Police Department Chaplain
3. **PLEDGE OF ALLEGIANCE** – Girl Scout Troop 921

4. **ROLL CALL OF CITY COUNCIL MEMBERS**

PRESENT: Cheng, Kwan, Wang, Cao, and Verlato
ABSENT: None

5. **SUPPLEMENTAL INFORMATION FROM CITY MANAGER REGARDING AGENDA ITEMS**

City Manager Lazzaretto had nothing to report and congratulated City Clerk Glasco on his retirement; and he thanked him for his years of service as City Clerk and all his historical knowledge of the City of Arcadia.

6. **PRESENTATIONS TO OUTGOING CITY CLERK GENE GLASCO**

Presentation by Vicky Paul on behalf of Supervisor Kathryn Barger

Presentation by Maile Plan on behalf of Congresswoman Judy Chu

Presentation by Erica Nam on behalf of Senator Anthony Portantino

Presentation by Fion Lam on behalf of Assemblymember Mike Fong

Presentation by Arcadia Unified School District Board Vice President Raymond Cheung and Superintendent Dr. David Vannasdall

Presentation by Brian Greene and Karen McNair of the Arcadia Chamber of Commerce

Presentation by Mayor April Verlato

Remarks by outgoing City Clerk Gene Glasco

Mayor Verlato called for recess at 7:58 p.m.

Mayor Verlato reconvened at 8:05 p.m.

7. **PRESENTATIONS**

- a. Presentation of Education and Sharing Day Proclamation to Rabbi Sholom Stiefel, Chabad of Arcadia.
- b. Presentation of Mayor's Certificates of Commendation to Girl Scout Troop 5541 for receiving the Gold Award.

8. PUBLIC HEARING

- a. Resolution No. 7558 establishing and adjusting various fees for City services.
CEQA: Not a Project
Recommended Action: Adopt

Interim Administrative Services Director Chen presented the Staff Report.

Mayor Verlato opened the Public Hearing.

No one appeared.

Mayor Pro Tem Cao made a motion to close the Public Hearing.

Mayor Verlato closed the Public Hearing.

A motion was made by Council Member Wang, seconded by Mayor Pro Tem Cao, and carried on a roll call vote to adopt Resolution No. 7558 establishing and adjusting various fees for City services.

AYES: Wang, Cao, Cheng, Kwan, and Verlato
NOES: None
ABSENT: None

9. PUBLIC COMMENT

Brian Greene, President of the Arcadia Chamber of Commerce, appeared and announced the Arcadia Chamber Golf Classic fundraiser will be held at the California Country Club on May 9, and provided information about the event.

David Arvizu, an Arcadia resident, appeared and requested the City Council send Caltrans a letter requesting an extension of the soundwall project over the Second Avenue overpass.

Alyson Parker, a representative from Game Day Men's Health, appeared and spoke about their new men's health clinic coming to Arcadia, and invited all to attend the grand opening in July.

Angela Tsai, an Arcadia resident, appeared and asked the City Council to call for an immediate ceasefire against Gaza.

Rebecca Edwards and Briana Robinson, with Miss Grand California, appeared and provided information about the next Miss Grand California Pageant.

10. REPORTS FROM MAYOR, CITY COUNCIL AND CITY CLERK *(including reports from the City Council related to meetings attended at City expense [AB 1234]).*

Mayor Verlato asked for support from two Council Members to add an item to a future agenda that would support the reform of Proposition 47; Council Member Kwan and Mayor Pro Tem Cao concurred.

Mayor Pro Tem Cao provided a report on the various events that he attended or will be attending as a representative of the City; and he congratulated Council Member Wang for earning the esteemed "Congressional Women of the Year" award from Representative Judy Chu.

Council Member Cheng wished City Clerk Glasco the best on his retirement.

Council Member Wang thanked the City of Arcadia and Council members for their support in helping her achieve the “Congressional Women of the Year” award.

Council Member Kwan congratulated Council member Wang for her hard work and dedication to the City and achieving the “Congressional Women of the Year” award.

Mayor Verlato asked for support from two Council Members to add an item to a future agenda to discuss a letter of support to extend the soundwall over the Second Avenue overpass; Council Member Wang and Council Member Kwan concurred.

Mayor Verlato expressed her opposition to the proposed extension to Measure H; she announced that she will be sending a letter in support of California Assembly Bill 2485; she provided a report on the various events that she attended or will be attending as a representative of the City; she further announced that Coffee with the Mayor will be held May 21 at 9:00 a.m.; and she presented Council Member Wang with a Certificate of Commendation for receiving the “Congressional Women of the Year” award, and congratulated her for receiving that recognition.

11. CONSENT CALENDAR

- a. Special and Regular Meeting Minutes of March 19, 2024, and Special Meeting Minutes of March 23, 2024.
CEQA: Not a Project
Recommended Action: Approve
- b. Resolution No. 7550 authorizing submittal of the Fiscal Year 2023-24 Transportation Development Act – Article 4 Claim Forms to receive capital and operating funds for Arcadia Transit.
CEQA: Not a Project
Recommended Action: Adopt
- c. Resolutions for the quitclaim/vacation of easements for the Alexan Azalea Mixed-Use Project.

Resolution No. 7551 quitclaiming a public access easement for sewer purposes over the property at 150 North Santa Anita Avenue and finding no further environmental review is required pursuant to Public Resources Code Section 21166 and State CEQA Guidelines Section 15162.

CEQA: No Further Environmental Review is Required
Recommended Action: Adopt

Resolution No. 7552 ordering the vacation of a public utility easement that was previously retained in the vacation of the east/west alley within the block bounded by Santa Anita Avenue, Santa Clara Street, First Avenue and Wheeler Avenue and finding no further environmental review is required pursuant to Public Resources Code Section 21166 and State CEQA Guidelines Section 15162

CEQA: No Further Environmental Review is Required
Recommended Action: Adopt

- d. Resolution No. 7548 adopting updated "Vehicle Miles Traveled" thresholds of significance for purposes of analyzing transportation impacts under the California Environmental Quality Act ("CEQA").
CEQA: Exempt
Recommended Action: Adopt
- e. Resolution No. 7553 amending the Fiscal Year 2022-23 Capital Improvement Program Budget (Project 41850823), authorizing a supplemental budget appropriation for design and construction services for the new compressed natural gas facility at the Public Works Services yard in the amount of \$1,130,000, offset by a reduction in Federal Section 5307 and Proposition A Funds.
CEQA: Exempt
Recommended Action: Adopt
- f. Resolution No. 7555 amending the Fiscal Year 2023-24 General Fund Budget, authorizing a supplemental budget appropriation for the purchase of paramedic supplies in the amount of \$25,000, offset by a reduction in the General Fund Reserve; and approving a Change Order to the Purchase Order with Life-Assist Inc., increasing the threshold limit of the Purchase Order amount overall.
CEQA: Not a Project
Recommended Action: Adopt and Approve
- g. Resolution No. 7556 amending the Fiscal Year 2023-24 General Fund Budget, authorizing a supplemental budget appropriation for fire apparatus and service repairs in the amount of \$100,000, offset by a reduction in the General Fund Reserve; and approving a Change Order to the Purchase Order with Performance Truck Repair Inc. in the amount of \$100,000.
CEQA: Not a Project
Recommended Action: Adopt and Approve
- h. Resolution No. 7559 amending Resolution No. 7383 establishing compensation and related benefits for City Council, Executive Management, Management, and Unrepresented Confidential Employees for July 1, 2021, through June 30, 2024 (City Clerk).
CEQA: Not a Project
Recommended Action: Adopt
- i. Reject the bid from Phoenix Contracting for one custom enclosed mobile trailer; and award the bid and Purchase Order to the next lowest bidder, New Trend Custom Trailer Inc., in an amount not to exceed \$80,500.
CEQA: Not a Project
Recommended Action: Approve
- j. Purchase Order with 72 Hour LLC dba National Auto Fleet Group for the purchase of one 2024 Toyota Camry and one 2024 Toyota RAV4 in the amount of \$79,397.50.
CEQA: Not a Project
Recommended Action: Approve
- k. Purchase Order with 72 Hour LLC dba National Auto Fleet Group for the purchase of two Ford Police Interceptor Patrol Utility vehicles in the amount of \$103,121.46.
CEQA: Not a Project
Recommended Action: Approve

City Attorney Maurer noted for the record that, due to a conflict of interest, Mayor Verlato and Council Member Kwan will abstain from voting on Consent Item 11.c. ; he further noted that Resolution No. 7552 of 11.c indicates that the utilities have been relocated; however, the developer is still working with Southern California Edison to move those utilities; and he recommended that the City Council adopt Resolution No. 7552, with a note that the recording of that Resolution and the vacation of the east/west alley will not be processed until the utilities have been relocated.

It was moved by Mayor Pro Tem Cao, seconded by Council Member Cheng, and carried on a roll call vote to approve Consent Calendar Items 11.a through 11.k.

AYES: Cheng, Cao, Kwan, Wang, and Verlato
NOES: None
ABSTAIN: Kwan and Verlato (only for Item 11.c.)
ABSENT: None

12. CITY MANAGER

- a. Presentation on Rio Hondo/San Gabriel River Water Quality Group Regional Stormwater Project Alternative.

City Manager Lazzaretto presented the item.

A motion was made by Mayor Pro Tem Cao, seconded by Council member Wang, and carried on roll call vote to study the concept of using the City Hall lawn for the stormwater project.

AYES: Cao, Wang, Cheng, Kwan, and Verlato
NOES: None
ABSENT: None

- b. Consideration of call for review of the Planning Commission approval of Multiple Family Architectural Design Review No. MFADR 23-03, Tentative Tract Map No. TTM 23-05 (84291), Healthy Tree Removal No. TRH 23-04, and Protected Tree Encroachment No. TRE 23-10 for a 16-unit, contemporary style, multi-family residential condominium development at 314-326 S. Second Avenue.
CEQA: Exempt
Recommended Action: Provide Direction

City Manager Lazzaretto presented the item.

After discussion, Mayor Verlato and Council Member Wang supported Council Member Kwan's request to call this item up for review, placing this item on a future City Council agenda.

- c. Resolution No. 7557 amending the Fiscal Year 2023-24 Operating Budget, authorizing a supplemental budget appropriation for the Par 3 Golf Course emergency pole replacement in the amount of \$26,700, offset by a reduction in the Par 3 Fund; and approving the Purchase Order with Judge Netting, Inc. for the Par 3 Golf Course emergency pole replacement in the amount of \$26,700.
CEQA: Exempt
Recommended Action: Adopt and Approve

City Manager Lazzaretto presented the staff report.

A motion was made by Council Member Wang, seconded by Council member Kwan, and carried on roll call vote to adopt Resolution No. 7557 amending the Fiscal Year 2023-24 Operating Budget, authorizing a supplemental budget appropriation for the Par 3 Golf Course emergency pole replacement in the amount of \$26,700, offset by a reduction in the Par 3 Fund; and approved the Purchase Order with Judge Netting, Inc. for the Par 3 Golf Course emergency pole replacement.

AYES: Wang, Kwan, Cheng, Cao, and Verlatto
NOES: None
ABSENT: None

13. ADJOURNMENT

The City Council adjourned this meeting at 9:06 p.m. to Tuesday, May 7, 2024, at 4:00 p.m. in the Arcadia Police Department Community Room/Emergency Operations Center ("EOC").



Rachelle Arellano
Assistant City Clerk



STAFF REPORT

Development Services Department

DATE: May 7, 2024

TO: Honorable Mayor and City Council

FROM: Jason Kruckeberg, Assistant City Manager/Development Services Director
By: Jeramie Brogan, Management Analyst

SUBJECT: RESOLUTION NO. 7560 APPROVING PARTICIPATION IN YEAR 4 OF THE LOS ANGELES URBAN COUNTY PERMANENT LOCAL HOUSING ALLOCATION (“PLHA”) PROGRAM; IDENTIFYING PROPOSED ACTIVITIES FOR \$966,044 IN PLHA FUNDING; AND AUTHORIZING THE MAYOR, OR DESIGNEE, TO SIGN A REIMBURSABLE CONTRACT WITH THE LOS ANGELES COUNTY DEVELOPMENT AUTHORITY (“LACDA”)
CEQA: Not A Project
Recommendation: Adopt

SUMMARY

In Fiscal Years 2020-21, 2021-22, and 2022-23, the City of Arcadia was allocated a combined total of \$799,154 in Permanent Local Housing Allocation (“PLHA”) Program funding, as part of the Senate Bill (“SB”) 2 legislation signed into law in 2017. The City Council previously approved two resolutions, in October 2020 and June 2021, authorizing use of these funds for homelessness programs and/or towards affordable housing development in partnership with the San Gabriel Valley Regional Housing Trust. In May 2023, the City Council approved a third resolution, approving the third year of funding, and incorporating the previous years’ funding. Due to a PLHA requirement that participating cities have a State-approved Housing Element, Arcadia’s funds have been inaccessible to date. However, in February 2024, the City fulfilled this requirement, and Arcadia’s previously held PLHA funding will be released pending the execution of a reimbursable contract with the Los Angeles County Development Authority (“LACDA”).

For Year 4 of the program, the City of Arcadia’s PLHA allocation is \$166,890 in new funding, which will be added to previous years’ funding balance. It is recommended that the City Council adopt Resolution No. 7560 approving participation in Year 4 of the Los Angeles Urban County PLHA Program; identifying the use of \$966,044 in combined PLHA funding to assist persons in Arcadia who are experiencing or at-risk of homelessness, and/or as matching funds to the San Gabriel Valley Regional Housing Trust; and authorizing the Mayor, or designee, to sign a reimbursable contract with the Los Angeles County Development Authority (“LACDA”).

BACKGROUND

The PLHA is a Senate Bill 2 (“SB 2”) funded program that was approved by the State legislature in 2017. It is designed to provide an ongoing annual source of funding through State Property Transfer Fees. Funds can be used for construction of affordable housing, programs to assist persons who are experiencing or at risk of homelessness, or other housing-related assistance programs for low-to-moderate income households. Similar to the Community Development Block Grant program for non-entitlement cities, PLHA funding is first allocated to a regional entity, in this case the LACDA. The funding is then distributed annually to individual participating cities according to an allocation formula over a five-year period. Unexpended program funds may be carried over from year to year but must be used within five years of their original allocation date.

The City has previously adopted three resolutions relating to PLHA funds. Resolution No. 7336 was adopted in October 2020, approving participation in Year 1 of the program, and allocating \$182,505 in funding for homelessness-related programs. Resolution No. 7374 was adopted in June 2021, approving participation in Year 2 of the program, and allocating an additional \$283,670 in PLHA funds for homelessness programs and adding the optional use of funds for work with the San Gabriel Valley Regional Housing Trust on a future affordable housing project. In May 2023, the City Council approved Resolution No. 7494 allocating the carryover of Year 1 and 2 PLHA funding totaling \$799,154, which also included the new Year 3 PLHA funding of \$332,979, for the activity of homelessness services and prevention programs. All of this combined funding has been targeted to support the City’s ongoing contract with Los Angeles Centers for Alcohol and Drug Abuse (“LA CADA”) for homeless supportive case management services. The use of any remaining PLHA funds not spent on homelessness services and prevention programs is allocated as matching funds for the San Gabriel Valley Regional Housing Trust (“SGVRHT”).

Until recently, Arcadia’s PLHA funding has been inaccessible due to the City’s lack of a certified Housing Element. SB 2 states that a city must have an adopted, certified Housing Element to receive PLHA funding. The City fulfilled the certification requirement in February 2024, when the California Department of Housing and Community Development found Arcadia’s Housing Element to be in substantial compliance with State law; therefore, the City can begin the process of executing a contract with the County to receive access to all of the funds.

On April 1, 2024, LACDA issued a bulletin listing the Year 4 PLHA funding allocations for each participating city. Arcadia is listed as eligible to receive \$166,890 in Year 4 PLHA funding. To allocate these funds, the City is required to adopt and submit a resolution to LACDA by May 31, 2024, listing the program activities that will be funded. A copy of the April 1, 2024, LACDA bulletin is included as Attachment No. 2. To ensure that the City’s previously approved Year 1-3 PLHA funds totaling \$799,154 remain active and available

for future use, allocation and re-approval of this funding is also recommended as part of the approval of Year 4 PLHA funds.

DISCUSSION

The SB 2 legislation relating to PLHA funds specifies what eligible activities these funds can be used to finance. Activities can be broadly categorized as follows:

1. Activities related to the construction or preservation of affordable housing or supportive housing;
2. Matching funds to regional housing trusts;
3. Homelessness services and prevention programs;
4. Accessibility modifications for lower-income, owner-occupied housing;
5. Acquisition and rehabilitation of foreclosed or vacant homes; and
6. Programs that expand homeownership opportunities including but not limited to down-payment assistance programs.

Of the eligible activities, it is recommended that the City continue to allocate its carryover Year 1-3 PLHA funding totaling \$799,154, and allocate its new Year 4 PLHA funding totaling \$166,890, for the activity of homelessness services and prevention programs. Specifically, it is recommended that these monies be used to fund the City's ongoing contract with LA CADA for homeless supportive case management. It is further recommended that the City Council authorize the use of any remaining PLHA funds not spent on homelessness services and prevention programs for matching funds for the SGVRHT. The City's Year 1 and Year 2 PLHA funds have a spending deadline of December 31, 2024. Year 3 PLHA funds have a spending deadline of December 31, 2025, and Year 4 funds have a spending deadline of December 31, 2026. Using any unspent PLHA funds as matching funds is recommended in lieu of allowing these funds to expire and be returned to the State.

Once the City's pending contract with LACDA is finalized, reimbursement will be requested for past homeless supportive case management services provided by LA CADA, beginning at the start of their contract in July 2022. Current and future contract costs will be submitted on an ongoing basis, subject to funding availability. Any remaining PLHA funds not expended by the respective deadlines will be provided as matching funds to the SGVRHT, in support of their efforts to create affordable housing within the San Gabriel Valley region.

In its April 1, 2024, bulletin, LACDA acknowledged that PLHA funding has experienced a significant change from previous years due to real estate transactions in 2022. While

considered to be a permanent funding source, the revenue from SB 2 will vary from year to year, as revenue is dependent on real estate transactions with fluctuating activity.

ENVIRONMENTAL ANALYSIS

The proposed action does not constitute a project under the California Environmental Quality Act (“CEQA”), based on Section 15061(b)(3) of the CEQA Guidelines, as it can be seen with certainty that it will have no impact on the environment.

FISCAL IMPACT

The PLHA Program is a SB 2 funded program that provides an ongoing annual source of funding through State Property Transfer Fees. The City has been allocated a combined \$966,044 of funding for Years 1-4 of the PLHA Program based on the State’s allocation formula. No additional funding is required to participate in the program. If the City does not request the funds and identify a purpose for them, the funds will be returned to the State. Participation in the program will result in a positive impact in that other existing funds would not need to be utilized for this portion of homeless case management and/or future coordination with the San Gabriel Valley Housing Trust. If PLHA funding is not utilized, it is likely that these types of programs would need to be supported with General Fund monies.

RECOMMENDATION

It is recommended that the City Council determine that this action does not constitute a project under the California Environmental Quality Act (“CEQA”); and adopt Resolution No. 7560 approving participation in Year 4 of the Los Angeles Urban County Permanent Local Housing Allocation (“PLHA”) Program, identifying proposed activities for \$966,044 in PLHA Funding, and authorizing the Mayor, or designee, to sign a reimbursable contract with the Los Angeles County Development Authority (“LACDA”).

Approved:



Dominic Lazzaretto
City Manager

Attachment No. 1: Resolution No. 7560
Attachment No. 2: April 1, 2024, LACDA Bulletin

RESOLUTION NO. 7560

A RESOLUTION OF THE CITY COUNCIL OF THE CITY OF ARCADIA APPROVING PARTICIPATION IN YEAR 4 OF THE LOS ANGELES URBAN COUNTY PERMANENT LOCAL HOUSING ALLOCATION ("PLHA") PROGRAM; IDENTIFYING PROPOSED ACTIVITIES FOR \$966,044 IN PLHA FUNDING; AND AUTHORIZING THE MAYOR, OR DESIGNEE, TO SIGN A REIMBURSABLE CONTRACT WITH THE LOS ANGELES COUNTY DEVELOPMENT AUTHORITY ("LACDA")

WHEREAS, the City of Arcadia desires to participate in Year 4 of the Los Angeles Urban County Permanent Local Housing Allocation ("PLHA") Program; and

WHEREAS, the City intends to authorize the execution of a contract with the Los Angeles County Development Authority acting on behalf of the County of Los Angeles in order to receive said PLHA funds.

NOW, THEREFORE, THE CITY COUNCIL OF THE CITY OF ARCADIA HEREBY RESOLVES AS FOLLOWS:

SECTION 1. The City Council approves the use of \$799,154 in combined Year 1-3 PLHA funds, and \$166,890 in new Year 4 PLHA funds, for the activities of assisting persons in Arcadia who are experiencing or at risk of homelessness and/or as matching funds to the San Gabriel Valley Regional Housing Trust.

SECTION 2. The City Council authorizes the Mayor, or his/her designee, to execute any and all documents, including a reimbursable contract with the Los Angeles County Development Authority acting on behalf of the County of Los Angeles, necessary for participation in the Los Angeles Urban County PLHA Program on behalf of the City of Arcadia.

SECTION 3. The City Council determines that the proposed action does not constitute a project under the California Environmental Quality Act ("CEQA"), based on

Section 15061(b)(3) of the CEQA Guidelines.

SECTION 4. The City Clerk shall certify to the adoption of this Resolution.

Passed, approved and adopted this 7th day of May, 2024.

Mayor of the City of Arcadia

ATTEST:

City Clerk

APPROVED AS TO FORM:



Michael J. Maurer
City Attorney



GMU BULLETIN

700 West Main Street, Alhambra, CA 91801

NUMBER: PLHA-24-0004	SUBJECT: 2022 PROGRAM ALLOCATIONS, YEAR 4 FOR THE PERMANENT LOCAL HOUSING ALLOCATION (PLHA) PROGRAM FOR URBAN COUNTY PARTICIPATING CITIES
DATE: April 1, 2024	EFFECTIVE DATE: IMMEDIATELY
	PAGE 1 OF 2

TO: PARTICIPATING CITIES

The purpose of this bulletin is to provide our Participating Cities (Cities) an update on the Permanent Local Housing Allocation Program (PLHA) funding for Year 4.

The State of California Department of Housing and Community Development released the NOFA for Year 4 in December 2023 and announced that the County of Los Angeles (County) will receive an allocation of \$9,451,755.00. Funding has experienced a significant change from previous years due to the real estate transactions in 2022. Cities who have a State-approved Housing Element are invited to follow the instructions below to program their PLHA Year 4 allocation to implement eligible affordable housing programs. Cities can continue to fund existing projects using funding from multiple years.

Attachment A provides the new PLHA Year 4 allocation amounts available to Cities that qualify and wish to utilize these funds for current or new eligible activities. To receive PLHA Year 4 funding, Cities with a State-approved Housing Element who wish to use their available allocation for PLHA Eligible Activities, must submit a Letter of Intent and proposed Exhibit A form to opt-in and receive funding. If applicable, the Letter of Intent must include concise details of the proposed Activity and Sub-Activity and describe how the City will spend the funds by December 31, 2026.

Please consider the complexity of the project being proposed, available resources, and whether the funding amount can be expended by the expenditure deadline. Because the shared allocation limits the amount of funding available to each jurisdiction, PLHA may not be the best funding source for all eligible activities. If you intend to make a change to an existing project that will reallocate funding by 10% or more, LACDA cannot guarantee a timely reimbursement and you may experience a delay in funding. If a city does not submit a Letter of Intent, the available allocation will be retained by the County and reallocated to Countywide program(s).

To All Participating Agencies

April 1, 2024

Page Two

Please adhere to the following deadlines to receive funding:

1. April 15, 2024 - The Letter of Intent must be completed and submitted to the LACDA (Attachment E).
2. April 30, 2024 - Proposed Exhibit A form must be submitted (Attachment C); and
3. May 31, 2024 - City Council approval resolution must be submitted (Attachment D).

Please be aware that the County cannot issue PLHA funding to Cities until all conditions for funding and program/regulatory requirements have been met and LACDA receives an executed agreement for PLHA Year 4 funds from the State. It is also important to note that certain activity costs for projects receiving PLHA funding are eligible for reimbursement as long as the expenses are incurred no more than 12-months prior to execution of Standard Agreement between the State and the County.

Should you need assistance in this matter or have any questions related to the PLHA program, you may contact JoAnn Eros-Delgado, Contract Management Supervisor at (626) 586-1749 or JoAnn.Eros@lacda.org or Jenny Salazar, PLHA Specialist, at (626) 586-1633 or Jenny.Salazar@lacda.org.

Sincerely,

Linda Jenkins (Apr 1, 2024 15:32 PDT)

LINDA JENKINS, Director

Community Development Division

				ATTACHMENT A	
Permanent Local Housing Allocation 2022				Total Urban County Entitlement	\$9,451,755
Redistricting Population Counts				Less Administration (5%)	<u>(\$472,588)</u>
Round 4				Total 2022-2023 to be Allocated	\$8,979,167



STAFF REPORT

Public Works Services Department

DATE: May 7, 2024

TO: Honorable Mayor and City Council

FROM: Paul Cranmer, Public Works Services Director
By: Carlos Aguilar, General Services Superintendent

SUBJECT: RESOLUTION NO. 7561 AMENDING THE FISCAL YEAR 2023-24 CAPITAL IMPROVEMENT PROGRAM BUDGET, AUTHORIZING A SUPPLEMENTAL BUDGET APPROPRIATION FOR THE CITY FACILITIES EXTERIOR PAINTING PROJECT (PROJECT NO. 17821024) IN THE AMOUNT OF \$26,920.33, OFFSET BY A REDUCTION IN THE CAPITAL OUTLAY FUND; AND APPROVE A CONTRACT WITH MACKONE DEVELOPMENT, INC. FOR THE CITY FACILITIES EXTERIOR PAINTING PROJECT IN THE AMOUNT OF \$326,920.33

CEQA: Exempt

Recommendation: Adopt and Approve

SUMMARY

The Public Works Services Department (“PWSD”) is responsible for the maintenance and repair of all City facilities, which includes painting improvements of City facilities. The exterior paint at City Hall, Arcadia Public Library, and Fire Station 105 as well as the interior paint at the Community Center ballroom, are showing signs of age and in need of maintenance. Utilizing Sourcewell, a national cooperative purchasing program, the City is able to streamline the process of procuring facility painting services at the best price possible.

It is recommended that the City Council adopt Resolution No. 7561 amending the Fiscal Year 2023-24 Capital Improvement Program budget, authorizing a supplemental budget appropriation for the City Facilities Exterior Painting Project (Project No. 17821024) in the amount of \$26,920.33, offset by a reduction in the Capital Outlay Fund; and approve a contract with Mackone Development, Inc. for the City Facilities Exterior Painting Project in the amount of \$326,920.33.

BACKGROUND

The PWSD is responsible for the maintenance and repair of all City facilities. The exterior paint at City Hall, Arcadia Public Library, and Fire Station 105 has become discolored and requires new painting. Exterior repainting not only improves the aesthetics of a facility,

but it also provides additional protection to the building from the environment and weather. Overall, repainting the exterior of buildings is essential for both functional and aesthetic reasons, ensuring the longevity, attractiveness, and structural integrity of buildings. In addition to the exterior painting at City Hall, Library, and Fire Station 105, the interior wall at the Community Center ballroom, which experienced damage from chairs being repeatedly placed against the wall, will be repainted. The paint on the wall is chipping and has become noticeably damaged. The Fiscal Year 2023-24 Capital Improvement Program (“CIP”) plans and budgets for this painting project.

DISCUSSION

As part of this project, all City Hall and Library exterior walls will be repainted. Fire Station 105 will receive a full exterior repainting, excluding the east wall facing the alley, which does not require exterior repainting at this time. The painting project will include spray and back roll work, a primer, and two coats of paint. The interior ballroom wall that is damaged at the Community Center will receive a complete repainting that will include brush and roller work, a primer, and two coats of paint. The paint used at the facilities will be color matched to the existing paint to preserve the facilities’ aesthetic. In addition, surrounding surfaces and landscaping near project areas will be covered with plastic sheeting for protection. The repainting of the facilities will not only provide aesthetic improvements but will also increase protection against weathering, cover the stucco cracks, and help preserve the wall materials.

Utilizing Sourcewell, a national cooperative purchasing program, the City is able to streamline the procurement process for these services at a lower cost than the traditional competitive bidding process. The California Government Code authorizes public agencies to participate in cooperative purchasing agreements such as those established by Sourcewell, while remaining within the City’s adopted rules and procedures for purchasing. Sourcewell awarded a contract to Mackone Development, Inc. for a series of painting construction contract services, including those needed for the City Facilities Exterior Painting Project. A copy of the agreement between Sourcewell and Mackone Development, Inc. is attached. The bidding process and the contract have been reviewed by the PWSD and meet the City’s procurement requirements. The City has previously contracted with Mackone Development, Inc. and has been satisfied with their service.

ENVIRONMENTAL ANALYSIS

This Project is considered a Class 1 exemption as defined in Section 15301(a) “Existing Facilities” projects of the California Environmental Quality Act (“CEQA”), which exempts projects consisting of alterations and repairs to existing facilities such as repainting.

FISCAL IMPACT

The total cost for the City Facilities Exterior Painting Project is \$326,920.33. Funds in the amount of \$300,000 have been budgeted in the Fiscal Year 2023-24 Capital Improvement Program budget for the City Facilities Exterior Painting Project. Therefore, a supplemental appropriation of \$26,920.33 is being requested from the Capital Outlay Fund for Project No. 17821024, account 302-1701-8210. This increase was not anticipated at the time of budget development and is largely due to the rising cost of materials in the construction industry. Adding the Community Center to this effort will reduce costs compared to contracting for it separately, at a later time.

RECOMMENDATION

It is recommended that the City Council determine that this project is a Class 1 exemption under the California Environmental Quality Act (“CEQA”); and adopt Resolution No. 7561 amending the Fiscal Year 2023-24 Capital Improvement Program budget, authorizing a supplemental budget appropriation for the City Facilities Exterior Painting Project (Project No. 17821024) in the amount of \$26,920.33, offset by a reduction in the Capital Outlay Fund; and approve a contract with Mackone Development, Inc. for the City Facilities Exterior Painting Project in the amount of \$326,920.33.

Approved:



Dominic Lazzaretto
City Manager

Attachments: Resolution No. 7561
Sourcewell Contract
Proposed Construction Contract

RESOLUTION NO. 7561

RESOLUTION NO. 7561 AMENDING THE FISCAL YEAR 2023-24 CAPITAL IMPROVEMENT PROGRAM BUDGET, AUTHORIZING A SUPPLEMENTAL BUDGET APPROPRIATION FOR THE CITY FACILITIES EXTERIOR PAINTING PROJECT (PROJECT NO. 17821024) IN THE AMOUNT OF \$26,920.33, OFFSET BY A REDUCTION IN THE CAPITAL OUTLAY FUND

WHEREAS, the Fiscal Year 2023-24 Capital Improvement Program provides for painting improvements at City Hall, Library, Fire Station 105, and Community Center; and

WHEREAS, the exterior and interior paint at these facilities is showing signs of age and wear and are in need of maintenance; and

WHEREAS, the total amount of \$326,920.33 is needed for the City Facilities Exterior Painting Project; and

WHEREAS, only \$300,000 was included in the Fiscal Year 2023-24 Capital Improvement Program Budget for this project; and

WHEREAS, an amendment to the Fiscal Year 2023-24 Capital Improvement Program Budget authorizing a supplemental budget appropriation in the amount of \$26,920.33 for Project 17821024 (302-1701-8210) is needed for the City Facilities Exterior Painting Project; and

WHEREAS, the supplemental budget appropriation will be offset by a reduction in the Capital Outlay Fund; and

WHEREAS, the City Manager has certified that there are sufficient reserves available in the Capital Outlay Fund.

NOW, THEREFORE, THE CITY COUNCIL OF THE CITY OF ARCADIA, CALIFORNIA, DOES FIND, DETERMINE AND RESOLVE AS FOLLOWS:

SECTION 1. The sum of Twenty-Six Thousand, Nine Hundred Twenty Dollars and

Thirty-Three Cents (\$26,920.33) is hereby appropriated in the Capital Improvement Program Budget (Project 17821024 Account 302-1701-8210) for the forgoing purposes, offset with an equal reduction in the Capital Outlay Fund.

SECTION 2. The City Clerk shall certify to the adoption of this Resolution.

Passed, approved and adopted this 7th day of May, 2024.

Mayor of the City of Arcadia

ATTEST:

City Clerk

APPROVED AS TO FORM:



Michael J. Maurer
City Attorney



Indefinite Delivery-Indefinite Quantity Construction Contract

Contract Number: CA-R8-GB-101723-MDI

Service Type: General Building

This Indefinite Delivery-Indefinite Quantity Construction Contract (Contract) is between **Sourcewell**, 202 12th Street Northeast, P.O. Box 219, Staples, MN 56479 and **Mackone Development Inc, 2244 Beverly Blvd, Los Angeles, CA 90057** (Contractor).

Sourcewell is a State of Minnesota local government agency and service cooperative created under the laws of the State of Minnesota (Minnesota Statutes Section 123A.21) that offers cooperative procurement solutions to government entities. Participation is open to federal, state and municipal governmental entities, K-12 and higher education entities, nonprofit entities, tribal governments, and other public entities located within the United States.

The Contractor desires to contract with Sourcewell to provide construction services to entities that access Sourcewell's indefinite delivery-indefinite quantity (IDIQ) construction contracts within the Service Region.

I. TERM OF CONTRACT

A. EFFECTIVE DATE. This Contract, including the General Terms and Conditions incorporated by reference, is effective upon the later of December 6, 2023 or the date of the final signature below.

B. EXPIRATION DATE AND EXTENSION. This Contract expires **December 5, 2024**, unless it is terminated sooner pursuant to Article XX of the General Terms and Conditions, which are incorporated into this Contract by reference. This Contract allows up to five additional one-year extensions upon the request of Sourcewell and written agreement with Contractor. Sourcewell retains the right to consider additional extensions beyond six years as required under exceptional circumstances.

II. REGION AND SERVICES

The Contractor's Region is: Region 8. The Contractor's IDIQ construction service type is: General Building. The Contractor **has** agreed to perform work outside the Region.

III. ADJUSTMENT FACTORS

The Contractor will perform any or all Tasks in the Construction Task Catalog for the Unit Price appearing therein multiplied by the following Adjustment Factors. See the General Terms and Conditions for additional information.

A. **Normal Working Hours – Prevailing Wage Rate Projects**: Work performed from 7:00 a.m. until 4:00 p.m. Monday to Friday, except Holidays. The Contractor will perform Tasks during Normal Working Hours for the Unit Price set forth in the CTC multiplied by the Adjustment Factor of: 1.3000.

B. **Other Than Normal Working Hours – Prevailing Wage Rate Projects:** Work performed from 4:00 p.m. to 7:00 a.m. Monday to Friday, and any time Saturday, Sunday and Holidays. The Contractor will perform Tasks during Other Than Normal Working Hours for the Unit Price set forth in the CTC multiplied by the Adjustment Factor of: 1.4500.

C. **Secured Facilities/OSHPD Prevailing - Wage Rate Projects:** Work performed from 7:00 a.m. until 4:00 p.m. Monday to Friday, except Holidays. The Contractor will perform Tasks during Normal Working Hours for the Unit Price set forth in the CTC multiplied by the Adjustment Factor of: 1.5500.

D. **All Union Wage Projects:** Work performed from 7:00 a.m. until 4:00 p.m. Monday to Friday, except Holidays. The Contractor will perform Tasks during Normal Working Hours for the Unit Price set forth in the CTC multiplied by the Adjustment Factor of: 1.4500.

E. **Non pre-priced Adjustment Factor:** To be applied to Work determined not to be included in the CTC but within the general scope of the work: 1.1500.

VI. AUTHORIZED REPRESENTATIVE

A. Sourcewell's Authorized Representative is its Chief Procurement Officer.

B. The Contractor's Authorized Representative is Matt Dugan. If the Contractor's Authorized Representative changes at any time during this Contract, Contractor must promptly notify Sourcewell in writing.

Sourcewell

Mackone Development Inc

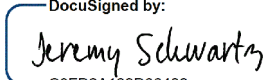
DocuSigned by:

C0FD2A139D06489...

DocuSigned by:

16CB5FA9EFBF49C...

By: _____
Jeremy Schwartz
Title: Chief Procurement Officer

By: _____
Matt Dugan
Title: Vice President

Date: 12/1/2023 | 11:21 AM CST

Date: 12/1/2023 | 9:13 AM PST

**CITY OF ARCADIA
CONSTRUCTION CONTRACT
MACKONE DEVELOPMENT, INC.**

1. PARTIES AND DATE.

This Contract is made and entered into this _____ day of _____, 20__ by and between the City of Arcadia, a public agency of the State of California ("City") and **Mackone Development, Inc.**, a **California Corporation**, with its principal place of business at **2244 Beverly Boulevard, Los Angeles, CA 90057** ("Contractor"). City and Contractor are sometimes individually referred to as "Party" and collectively as "Parties" in this Contract.

2. RECITALS.

2.1 City. City is a public agency organized under the laws of the State of California, with power to contract for services necessary to achieve its purpose.

2.2 Contractor. Contractor desires to perform and assume responsibility for the provision of certain construction services required by the City on the terms and conditions set forth in this Contract. Contractor represents that it is duly licensed and experienced in providing **painting** related construction services to public clients, that it and its employees or subcontractors have all necessary licenses and permits to perform the services in the State of California, and that it is familiar with the plans of City. The following license classifications are required for this Project: **C-33**.

2.3 Project. City desires to engage Contractor to render such services for the **City Facilities Exterior Painting Project** ("Project") as set forth in this Contract.

2.4 Project Documents & Certifications. Contractor has obtained, and delivers concurrently herewith, a performance bond, a payment bond, and all insurance documentation, as required by the Contract.

3. TERMS

3.1 Incorporation of Documents. This Contract includes and hereby incorporates in full by reference the following documents, including all exhibits, drawings, specifications and documents therein, and attachments and addenda thereto:

- Services/Schedule (Exhibit "A")
- Plans and Specifications (Exhibit "B")
- Special Conditions (Exhibit "C")
- Contractor's Certificate Regarding Workers' Compensation (Exhibit "D")
- Public Works Contractor Registration Certification (Exhibit "E")
- Payment and Performance Bonds (Exhibit "F")
- Federal Requirements (Exhibit "G")
- Addenda
- Change Orders executed by the City
- **Current** Edition of the Standard Specifications for Public Works Construction (The Greenbook), Excluding Sections 1-9
- Notice Inviting Bids, if any
- Instructions to Bidders, if any

- Contractor's Bid

3.2 Contractor's Basic Obligation; Scope of Work. Contractor promises and agrees, at its own cost and expense, to furnish to the City all labor, materials, tools, equipment, services, and incidental and customary work necessary to fully and adequately complete the Project, including all structures and facilities necessary for the Project or described in the Contract (hereinafter sometimes referred to as the "Work"), for a Total Contract Price as specified pursuant to this Contract. All Work shall be subject to, and performed in accordance with the above referenced documents, as well as the exhibits attached hereto and incorporated herein by reference. The plans and specifications for the Work are further described in Exhibit "B" attached hereto and incorporated herein by this reference. Special Conditions, if any, relating to the Work are described in Exhibit "C" attached hereto and incorporated herein by this reference.

3.2.1 Change in Scope of Work. Any change in the scope of the Work, method of performance, nature of materials or price thereof, or any other matter materially affecting the performance or nature of the Work shall not be paid for or accepted unless such change, addition or deletion is approved in writing by a valid change order executed by the City. Should Contractor request a change order due to unforeseen circumstances affecting the performance of the Work, such request shall be made within five (5) business days of the date such circumstances are discovered or shall waive its right to request a change order due to such circumstances. If the Parties cannot agree on any change in price required by such change in the Work, the City may direct the Contractor to proceed with the performance of the change on a time and materials basis.

3.2.2 Substitutions/"Or Equal". Pursuant to Public Contract Code Section 3400(b), the City may make a finding that designates certain products, things, or services by specific brand or trade name. Unless specifically designated in this Contract, whenever any material, process, or article is indicated or specified by grade, patent, or proprietary name or by name of manufacturer, such Specifications shall be deemed to be used for the purpose of facilitating the description of the material, process or article desired and shall be deemed to be followed by the words "or equal."

Contractor may, unless otherwise stated, offer for substitution any material, process or article which shall be substantially equal or better in every respect to that so indicated or specified in this Contract. However, the City may have adopted certain uniform standards for certain materials, processes and articles. Contractor shall submit requests, together with substantiating data, for substitution of any "or equal" material, process or article no later than thirty-five (35) days after award of the Contract. To facilitate the construction schedule and sequencing, some requests may need to be submitted before thirty-five (35) days after award of Contract. Provisions regarding submission of "or equal" requests shall not in any way authorize an extension of time for performance of this Contract. If a proposed "or equal" substitution request is rejected, Contractor shall be responsible for providing the specified material, process or article. The burden of proof as to the equality of any material, process or article shall rest with Contractor.

The City has the complete and sole discretion to determine if a material, process or article is an "or equal" material, process or article that may be substituted. Data required to substantiate requests for substitutions of an "or equal" material, process or article data shall include a signed affidavit from Contractor stating that, and describing how, the substituted "or equal" material, process or article is equivalent to that specified in every way except as listed on the affidavit. Substantiating data shall include any and all illustrations, specifications, and other

relevant data including catalog information which describes the requested substituted “or equal” material, process or article, and substantiates that it is an “or equal” to the material, process or article. The substantiating data must also include information regarding the durability and lifecycle cost of the requested substituted “or equal” material, process or article. Failure to submit all the required substantiating data, including the signed affidavit, to the City in a timely fashion will result in the rejection of the proposed substitution.

Contractor shall bear all of the City’s costs associated with the review of substitution requests. Contractor shall be responsible for all costs related to a substituted “or equal” material, process or article. Contractor is directed to the Special Conditions (if any) to review any findings made pursuant to Public Contract Code section 3400.

3.3 Period of Performance and Liquidated Damages. Contractor shall perform and complete all Work under this Contract within **Forty-Five (45) calendar** days, beginning the effective date of the Notice to Proceed (“Contract Time”). Contractor shall perform its Work in strict accordance with any completion schedule, construction schedule or project milestones developed by the City. Such schedules or milestones may be included as part of Exhibits “A” or “B” attached hereto, or may be provided separately in writing to Contractor. Contractor agrees that if such Work is not completed within the aforementioned Contract Time and/or pursuant to any such completion schedule, construction schedule or project milestones developed pursuant to provisions of the Contract, it is understood, acknowledged and agreed that the City will suffer damage. Pursuant to Government Code Section 53069.85, Contractor shall pay to the City as fixed and liquidated damages the sum of **One Thousand Dollars and No Cents (\$1,000.00) per day** for each and every calendar day of delay beyond the Contract Time or beyond any completion schedule, construction schedule or Project milestones established pursuant to the Contract.

3.4 Standard of Performance; Performance of Employees. Contractor shall perform all Work under this Contract in a skillful and workmanlike manner, and consistent with the standards generally recognized as being employed by professionals in the same discipline in the State of California. Contractor represents and maintains that it is skilled in the professional calling necessary to perform the Work. Contractor warrants that all employees and subcontractors shall have sufficient skill and experience to perform the Work assigned to them. Finally, Contractor represents that it, its employees and subcontractors have all licenses, permits, qualifications and approvals of whatever nature that are legally required to perform the Work, including any required business license, and that such licenses and approvals shall be maintained throughout the term of this Contract. As provided for in the indemnification provisions of this Contract, Contractor shall perform, at its own cost and expense and without reimbursement from the City, any work necessary to correct errors or omissions which are caused by Contractor’s failure to comply with the standard of care provided for herein. Any employee who is determined by the City to be uncooperative, incompetent, a threat to the safety of persons or the Work, or any employee who fails or refuses to perform the Work in a manner acceptable to the City, shall be promptly removed from the Project by Contractor and shall not be re-employed on the Work.

3.5 Control and Payment of Subordinates; Contractual Relationship. City retains Contractor on an independent contractor basis and Contractor is not an employee of City. Any additional personnel performing the work governed by this Contract on behalf of Contractor shall at all times be under Contractor’s exclusive direction and control. Contractor shall pay all wages, salaries, and other amounts due such personnel in connection with their performance under this Contract and as required by law. Contractor shall be responsible for all reports and

obligations respecting such additional personnel, including, but not limited to: social security taxes, income tax withholding, unemployment insurance, and workers' compensation insurance.

3.6 City's Basic Obligation. City agrees to engage and does hereby engage Contractor as an independent contractor to furnish all materials and to perform all Work according to the terms and conditions herein contained for the sum set forth above. Except as otherwise provided in the Contract, the City shall pay to Contractor, as full consideration for the satisfactory performance by Contractor of the services and obligations required by this Contract, the below-referenced compensation in accordance with compensation provisions set forth in the Contract.

3.7 Compensation and Payment.

3.7.1 Amount of Compensation. As consideration for performance of the Work required herein, City agrees to pay Contractor the Total Contract Price of **THREE HUNDRED TWENTY-SIX THOUSAND, NINE HUNDRED TWENTY DOLLARS AND THIRTY-THREE CENTS (\$326,920.33)** ("Total Contract Price") provided that such amount shall be subject to adjustment pursuant to the applicable terms of this Contract or written change orders approved and signed in advance by the City.

3.7.2 Payment of Compensation. If the Work is scheduled for completion in thirty (30) or less calendar days, City will arrange for payment of the Total Contract Price upon completion and approval by City of the Work. If the Work is scheduled for completion in more than thirty (30) calendar days, City will pay Contractor on a monthly basis as provided for herein. On or before the fifth (5th) day of each month, Contractor shall submit to the City an itemized application for payment in the format supplied by the City indicating the amount of Work completed since commencement of the Work or since the last progress payment. These applications shall be supported by evidence which is required by this Contract and such other documentation as the City may require. The Contractor shall certify that the Work for which payment is requested has been done and that the materials listed are stored where indicated. Contractor may be required to furnish a detailed schedule of values upon request of the City and in such detail and form as the City shall request, showing the quantities, unit prices, overhead, profit, and all other expenses involved in order to provide a basis for determining the amount of progress payments.

3.7.3 Prompt Payment. City shall review and pay all progress payment requests in accordance with the provisions set forth in Section 20104.50 of the California Public Contract Code. However, no progress payments will be made for Work not completed in accordance with this Contract. Contractor shall comply with all applicable laws, rules and regulations relating to the proper payment of its employees, subcontractors, suppliers or others.

3.7.4 Contract Retentions. From each approved progress estimate, five percent (5%) will be deducted and retained by the City, and the remainder will be paid to Contractor. All Contract retention shall be released and paid to Contractor and subcontractors pursuant to California Public Contract Code Section 7107.

3.7.5 Other Retentions. In addition to Contract retentions, the City may deduct from each progress payment an amount necessary to protect City from loss because of: (1) liquidated damages which have accrued as of the date of the application for payment; (2) any sums expended by the City in performing any of Contractor's obligations under the Contract which Contractor has failed to perform or has performed inadequately; (3) defective Work not remedied; (4) stop notices as allowed by state law; (5) reasonable doubt that the Work can be completed for the unpaid balance of the Total Contract Price or within the scheduled completion

date; (6) unsatisfactory prosecution of the Work by Contractor; (7) unauthorized deviations from the Contract; (8) failure of Contractor to maintain or submit on a timely basis proper and sufficient documentation as required by the Contract or by City during the prosecution of the Work; (9) erroneous or false estimates by Contractor of the value of the Work performed; (10) any sums representing expenses, losses, or damages as determined by the City, incurred by the City for which Contractor is liable under the Contract; and (11) any other sums which the City is entitled to recover from Contractor under the terms of the Contract or pursuant to state law, including Section 1727 of the California Labor Code. The failure by the City to deduct any of these sums from a progress payment shall not constitute a waiver of the City's right to such sums.

3.7.6 Substitutions for Contract Retentions. In accordance with California Public Contract Code Section 22300, the City will permit the substitution of securities for any monies withheld by the City to ensure performance under the Contract. At the request and expense of Contractor, securities equivalent to the amount withheld shall be deposited with the City, or with a state or federally chartered bank in California as the escrow agent, and thereafter the City shall then pay such monies to Contractor as they come due. Upon satisfactory completion of the Contract, the securities shall be returned to Contractor. For purposes of this Section and Section 22300 of the Public Contract Code, the term "satisfactory completion of the contract" shall mean the time the City has issued written final acceptance of the Work and filed a Notice of Completion as required by law and provisions of this Contract. Contractor shall be the beneficial owner of any securities substituted for monies withheld and shall receive any interest thereon. The escrow agreement used for the purposes of this Section shall be in the form provided by the City.

3.7.7 Title to Work. As security for partial, progress, or other payments, title to Work for which such payments are made shall pass to the City at the time of payment. To the extent that title has not previously been vested in the City by reason of payments, full title shall pass to the City at delivery of the Work at the destination and time specified in this Contract. Such transferred title shall in each case be good, free and clear from any and all security interests, liens, or other encumbrances. Contractor promises and agrees that it will not pledge, hypothecate, or otherwise encumber the items in any manner that would result in any lien, security interest, charge, or claim upon or against said items. Such transfer of title shall not imply acceptance by the City, nor relieve Contractor from the responsibility to strictly comply with the Contract, and shall not relieve Contractor of responsibility for any loss of or damage to items.

3.7.8 Labor and Material Releases. Contractor shall furnish City with labor and material releases from all subcontractors performing work on, or furnishing materials for, the Work governed by this Contract prior to final payment by City.

3.7.9 Prevailing Wages. Contractor is aware of the requirements of California Labor Code Section 1720 et seq., and 1770 et seq., as well as California Code of Regulations, Title 8, Section 16000 et seq., ("Prevailing Wage Laws"), which require the payment of prevailing wage rates and the performance of other requirements on "public works" and "maintenance" projects. Since the Services are being performed as part of an applicable "public works" or "maintenance" project, as defined by the Prevailing Wage Laws, and if the total compensation is \$25,000 or more, Contractor agrees to fully comply with such Prevailing Wage Laws. City shall provide Contractor with a copy of the prevailing rates of per diem wages in effect at the commencement of this Contract. Contractor shall make copies of the prevailing rates of per diem wages for each craft, classification or type of worker needed to execute the Services available to interested parties upon request, and shall post copies at Contractor's

principal place of business and at the project site. Contractor shall defend, indemnify and hold the City, its officials, officers, employees and agents free and harmless from any claim or liability arising out of any failure or alleged failure to comply with the Prevailing Wage Laws. Contractor and any subcontractor shall forfeit a penalty of up to \$200 per calendar day or portion thereof for each worker paid less than the prevailing wage rates.

3.7.10 Apprenticeable Crafts. If the Total Contract Price exceeds \$35,000 and if Contractor employs workmen in an apprenticeable craft or trade, Contractor shall comply with the provisions of Section 1777.5 of the California Labor Code with respect to the employment of properly registered apprentices upon public works. The primary responsibility for compliance with said section for all apprenticeable occupations shall be with Contractor. The Contractor or any subcontractor that is determined by the Labor Commissioner to have knowingly violated Section 1777.5 shall forfeit as a civil penalty an amount not exceeding \$100 for each full calendar day of noncompliance, or such greater amount as provided by law.

3.7.11 Hours of Work. If the Total Contract Price exceeds \$25,000, Contractor is advised that eight (8) hours labor constitutes a legal day's work. Pursuant to Section 1813 of the California Labor Code, Contractor shall forfeit a penalty of \$25.00 per worker for each day that each worker is permitted to work more than eight (8) hours in any one calendar day and forty (40) hours in any one calendar week, except when payment for overtime is made at not less than one and one-half (1-1/2) times the basic rate for that worker.

3.7.12 Payroll Records. If the Total Contract Price exceeds \$25,000, Contractor and each subcontractor shall keep an accurate payroll record, showing the name, address, social security number, work classification, straight time and overtime hours worked each day and week, and the actual per diem wages paid to each journeyman, apprentice, worker, or other employee employed by him or her in connection with the public work. The payroll records shall be certified and shall be available for inspection at all reasonable hours at the principal office of Contractor in the manner provided in Labor Code section 1776. In the event of noncompliance with the requirements of this section, Contractor shall have 10 days in which to comply subsequent to receipt of written notice specifying in what respects such Contractor must comply with this section. Should noncompliance still be evident after such 10-day period, Contractor shall, as a penalty to City, forfeit not more than \$100.00 for each calendar day or portion thereof, for each worker, until strict compliance is effectuated. The amount of the forfeiture is to be determined by the Labor Commissioner. A contractor who is found to have violated the provisions of law regarding wages on Public Works with the intent to defraud shall be ineligible to bid on Public Works contracts for a period of one to three years as determined by the Labor Commissioner. Upon the request of the Division of Apprenticeship Standards or the Division of Labor Standards Enforcement, such penalties shall be withheld from progress payments then due. The responsibility for compliance with this section is on Contractor. The requirement to submit certified payroll records directly to the Labor Commissioner under Labor Code section 1771.4 shall not apply to work performed on a public works project that is exempt pursuant to the small project exemption specified in Labor Code Section 1771.4.

3.7.13 Contractor and Subcontractor Registration. If the Total Contract Price exceeds \$25,000, then pursuant to Labor Code sections 1725.5 and 1771.1, all contractors and subcontractors that wish to bid on, be listed in a bid proposal, or enter into a contract to perform public work must be registered with the Department of Industrial Relations. No bid will be accepted nor any contract entered into without proof of the contractor's and subcontractors' current registration with the Department of Industrial Relations to perform public work. Contractor is directed to review, fill out and execute the Public Works Contractor Registration Certification attached hereto as Exhibit "E" prior to contract execution. Notwithstanding the

foregoing, the contractor registration requirements mandated by Labor Code Sections 1725.5 and 1771.1 shall not apply to work performed on a public works project that is exempt pursuant to the small project exemption specified in Labor Code Sections 1725.5 and 1771.1.

3.7.14 Labor Compliance; Stop Orders. If the Total Contract Price exceeds \$25,000, Contractor acknowledges that it is aware that this Project is subject to compliance monitoring and enforcement by the Department of Industrial Relations. It shall be the Contractor's sole responsibility to evaluate and pay the cost of complying with all labor compliance requirements under this Contract and applicable law. Any stop orders issued by the Department of Industrial Relations against Contractor or any subcontractor that affect Contractor's performance of Work, including any delay, shall be Contractor's sole responsibility. Any delay arising out of or resulting from such stop orders shall be considered Contractor caused delay subject to any applicable liquidated damages and shall not be compensable by the City. Contractor shall defend, indemnify and hold the City, its officials, officers, employees and agents free and harmless from any claim or liability arising out of stop orders issued by the Department of Industrial Relations against Contractor or any subcontractor.

3.8 Performance of Work; Jobsite Obligations.

3.8.1 Water Quality Management and Compliance.

3.8.1.1 Water Quality Management and Compliance. Contractor shall keep itself and all subcontractors, staff, and employees fully informed of and in compliance with all local, state and federal laws, rules and regulations that may impact, or be implicated by the performance of the Work including, without limitation, all applicable provisions of the Federal Water Pollution Control Act (33 U.S.C. §§ 1300); the California Porter-Cologne Water Quality Control Act (Cal Water Code §§ 13000-14950); local ordinances regulating discharges of storm water; and any and all regulations, policies, or permits issued pursuant to any such authority regulating the discharge of pollutants, as that term is used in the Porter-Cologne Water Quality Control Act, to any ground or surface water in the State.

3.8.1.2 Compliance with the Statewide Construction General Permit. Contractor shall comply with all conditions of the most recent iteration of the National Pollutant Discharge Elimination System General Permit for Storm Water Discharges Associated with Construction Activity, issued by the California State Water Resources Control Board ("Permit"). It shall be Contractor's sole responsibility to file a Notice of Intent and procure coverage under the Permit for all construction activity which results in the disturbance of more than one acre of total land area or which is part of a larger common area of development or sale. Prior to initiating work, Contractor shall be solely responsible for preparing and implementing a Storm Water Pollution Prevention Plan (SWPPP) as required by the Permit. Contractor shall be responsible for procuring, implementing and complying with the provisions of the Permit and the SWPPP, including the standard provisions, and monitoring and reporting requirements as required by the Permit. The Permit requires the SWPPP to be a "living document" that changes as necessary to meet the conditions and requirements of the job site as it progresses through difference phases of construction and is subject to different weather conditions. It shall be Contractor's sole responsibility to update the SWPPP as necessary to address conditions at the project site.

3.8.1.3 Other Water Quality Rules Regulations and Policies. Contractor shall comply with the lawful requirements of any applicable municipality, drainage City, or local agency regarding discharges of storm water to separate storm drain systems or

other watercourses under their jurisdiction, including applicable requirements in municipal storm water management programs.

3.8.1.4 **Cost of Compliance.** Storm, surface, nuisance, or other waters may be encountered at various times during construction of The Work. Therefore, the Contractor, by submitting a Bid, hereby acknowledges that it has investigated the risk arising from such waters, has prepared its Bid accordingly, and assumes any and all risks and liabilities arising therefrom.

3.8.1.5 **Liability for Non-Compliance.** Failure to comply with the Permit is a violation of federal and state law. Pursuant to the indemnification provisions of this Contract, Contractor hereby agrees to defend, indemnify and hold harmless the City and its officials, officers, employees, volunteers and agents for any alleged violations. In addition, City may seek damages from Contractor for any delay in completing the Work in accordance with the Contract, if such delay is caused by or related to Contractor's failure to comply with the Permit.

3.8.1.6 **Reservation of Right to Defend.** City reserves the right to defend any enforcement action brought against the City for Contractor's failure to comply with the Permit or any other relevant water quality law, regulation, or policy. Pursuant to the indemnification provisions of this Contract, Contractor hereby agrees to be bound by, and to reimburse the City for the costs (including the City's attorney's fees) associated with, any settlement reached between the City and the relevant enforcement entity.

3.8.1.7 **Training.** In addition to the standard of performance requirements set forth in paragraph 3.4, Contractor warrants that all employees and subcontractors shall have sufficient skill and experience to perform the Work assigned to them without impacting water quality in violation of the laws, regulations and policies described in paragraph 3.8.1. Contractor further warrants that it, its employees and subcontractors will receive adequate training, as determined by City, regarding the requirements of the laws, regulations and policies described in paragraph 3.8.1 as they may relate to the Work provided under this Agreement. Upon request, City will provide the Contractor with a list of training programs that meet the requirements of this paragraph.

3.8.2 **Safety.** Contractor shall execute and maintain its work so as to avoid injury or damage to any person or property. Contractor shall comply with the requirements of the specifications relating to safety measures applicable in particular operations or kinds of work. In carrying out its Work, Contractor shall at all times be in compliance with all applicable local, state and federal laws, rules and regulations, and shall exercise all necessary precautions for the safety of employees appropriate to the nature of the Work and the conditions under which the Work is to be performed. Safety precautions as applicable shall include, but shall not be limited to, adequate life protection and lifesaving equipment; adequate illumination for underground and night operations; instructions in accident prevention for all employees, such as machinery guards, safe walkways, scaffolds, ladders, bridges, gang planks, confined space procedures, trenching and shoring, fall protection and other safety devices, equipment and wearing apparel as are necessary or lawfully required to prevent accidents or injuries; and adequate facilities for the proper inspection and maintenance of all safety measures. Furthermore, Contractor shall prominently display the names and telephone numbers of at least two medical doctors practicing in the vicinity of the Project, as well as the telephone number of the local ambulance service, adjacent to all telephones at the Project site.

3.8.3 **Laws and Regulations.** Contractor shall keep itself fully informed of and in compliance with all local, state and federal laws, rules and regulations in any manner

affecting the performance of the Contract or the Work, including all Cal/OSHA requirements, and shall give all notices required by law. Contractor shall be liable for all violations of such laws and regulations in connection with Work. If Contractor observes that the drawings or specifications are at variance with any law, rule or regulation, it shall promptly notify the City in writing. Any necessary changes shall be made by written change order. If Contractor performs any work knowing it to be contrary to such laws, rules and regulations and without giving written notice to the City, Contractor shall be solely responsible for all costs arising therefrom. City is a public entity of the State of California subject to certain provisions of the Health & Safety Code, Government Code, Public Contract Code, and Labor Code of the State. It is stipulated and agreed that all provisions of the law applicable to the public contracts of a municipality are a part of this Contract to the same extent as though set forth herein and will be complied with. Contractor shall defend, indemnify and hold City, its officials, officers, employees and agents free and harmless, pursuant to the indemnification provisions of this Contract, from any claim or liability arising out of any failure or alleged failure to comply with such laws, rules or regulations.

3.8.4 Permits and Licenses. Contractor shall be responsible for securing City permits and licenses necessary to perform the Work described herein, including, but not limited to, any required business license. While Contractor will not be charged a fee for any City permits, Contractor shall pay the City's business license fee, if any. Any ineligible contractor or subcontractor pursuant to Labor Code Sections 1777.1 and 1777.7 may not perform work on this Project.

3.8.5 Trenching Work. If the Total Contract Price exceeds \$25,000 and if the Work governed by this Contract entails excavation of any trench or trenches five (5) feet or more in depth, Contractor shall comply with all applicable provisions of the California Labor Code, including Section 6705. To this end, Contractor shall submit for City's review and approval a detailed plan showing the design of shoring, bracing, sloping, or other provisions to be made for worker protection from the hazard of caving ground during the excavation of such trench or trenches. If such plan varies from the shoring system standards, the plan shall be prepared by a registered civil or structural engineer.

3.8.6 Hazardous Materials and Differing Conditions. As required by California Public Contract Code Section 7104, if this Contract involves digging trenches or other excavations that extend deeper than four (4) feet below the surface, Contractor shall promptly, and prior to disturbance of any conditions, notify City of: (1) any material discovered in excavation that Contractor believes to be a hazardous waste that is required to be removed to a Class I, Class II or Class III disposal site; (2) subsurface or latent physical conditions at the site differing from those indicated by City; and (3) unknown physical conditions of an unusual nature at the site, significantly different from those ordinarily encountered in such contract work. Upon notification, City shall promptly investigate the conditions to determine whether a change order is appropriate. In the event of a dispute, Contractor shall not be excused from any scheduled completion date and shall proceed with all Work to be performed under the Contract, but shall retain all rights provided by the Contract or by law for making protests and resolving the dispute.

3.8.7 Underground Utility Facilities. To the extent required by Section 4215 of the California Government Code, City shall compensate Contractor for the costs of: (1) locating and repairing damage to underground utility facilities not caused by the failure of Contractor to exercise reasonable care; (2) removing or relocating underground utility facilities not indicated in the construction drawings; and (3) equipment necessarily idled during such work. Contractor shall not be assessed liquidated damages for delay caused by failure of City to provide for removal or relocation of such utility facilities.

3.8.8 Air Quality. Contractor must fully comply with all applicable laws, rules and regulations in furnishing or using equipment and/or providing services, including, but not limited to, emissions limits and permitting requirements imposed by the California Air Resources Board (CARB). Although CARB limits and requirements are more broad, Contractor shall specifically be aware of their application to "portable equipment", which definition is considered by CARB to include any item of equipment with a fuel-powered engine. Contractor shall indemnify City against any fines or penalties imposed by CARB, or any other governmental or regulatory agency for violations of applicable laws, rules and/or regulations by Contractor, its subcontractors, or others for whom Contractor is responsible under its indemnity obligations provided for in this Agreement.

3.8.9 State Recycling Mandates. Contractor shall comply with State Recycling Mandates. Any recyclable materials/debris collected by the contractor that can be feasibly diverted via reuse or recycling must be hauled by the appropriate handler for reuse or recycling.

3.9 Completion of Work. When Contractor determines that it has completed the Work required herein, Contractor shall so notify City in writing and shall furnish all labor and material releases required by this Contract. City shall thereupon inspect the Work. If the Work is not acceptable to the City, the City shall indicate to Contractor in writing the specific portions or items of Work which are unsatisfactory or incomplete. Once Contractor determines that it has completed the incomplete or unsatisfactory Work, Contractor may request a reinspection by the City. Once the Work is acceptable to City, City shall pay to Contractor the Total Contract Price remaining to be paid, less any amount which City may be authorized or directed by law to retain. Payment of retention proceeds due to Contractor shall be made in accordance with Section 7107 of the California Public Contract Code.

3.10 Claims; Government Code Claim Compliance.

3.10.1 Intent. Effective January 1, 1991, Section 20104 et seq., of the California Public Contract Code prescribes a process utilizing informal conferences, non-binding judicial supervised mediation, and judicial arbitration to resolve disputes on construction claims of \$375,000 or less. Effective January 1, 2017, Section 9204 of the Public Contract Code prescribes a process for negotiation and mediation to resolve disputes on construction claims. The intent of this Section is to implement Sections 20104 et seq. and Section 9204 of the California Public Contract Code. This Section shall be construed to be consistent with said statutes.

3.10.2 Claims. For purposes of this Section, "Claim" means a separate demand by the Contractor, after a change order duly requested in accordance with the terms of this Contract has been denied by the City, for (A) a time extension, (B) payment of money or damages arising from Work done by or on behalf of the Contractor pursuant to the Contract, or (C) an amount the payment of which is disputed by the City. Claims governed by this Section may not be filed unless and until the Contractor completes all procedures for giving notice of delay or change and for the requesting of a time extension or change order, including but not necessarily limited to the change order procedures contained herein, and Contractor's request for a change has been denied in whole or in part. Claims governed by this Section must be filed no later than fourteen (14) days after a request for change has been denied in whole or in part or after any other event giving rise to the Claim. The Claim shall be submitted in writing to the City and shall include on its first page the following in 16 point capital font: "THIS IS A CLAIM." Furthermore, the claim shall include the documents necessary to substantiate the claim. Nothing in this Section is intended to extend the time limit or supersede notice requirements

otherwise provided by contract for the filing of claims, including all requirements pertaining to compensation or payment for extra Work, disputed Work, and/or changed conditions. Failure to follow such contractual requirements shall bar any claims or subsequent lawsuits for compensation or payment thereon.

3.10.3 Supporting Documentation. The Contractor shall submit all claims in the following format:

3.10.3.1 Summary of claim merit and price, reference Contract Document provisions pursuant to which the claim is made

3.10.3.2 List of documents relating to claim:

- (A) Specifications
- (B) Drawings
- (C) Clarifications (Requests for Information)
- (D) Schedules
- (E) Other

3.10.3.3 Chronology of events and correspondence

3.10.3.4 Analysis of claim merit

3.10.3.5 Analysis of claim cost

3.10.3.6 Time impact analysis in CPM format

3.10.3.7 If Contractor's claim is based in whole or in part on an allegation of errors or omissions in the Drawings or Specifications for the Project, Contractor shall provide a summary of the percentage of the claim subject to design errors or omissions and shall obtain a certificate of merit in support of the claim of design errors and omissions.

3.10.3.8 Cover letter and certification of validity of the claim, including any claims from subcontractors of any tier, in accordance with Government Code section 12650 *et seq.*

3.10.4 City's Response. Upon receipt of a claim pursuant to this Section, City shall conduct a reasonable review of the claim and, within a period not to exceed 45 days, shall provide the Contractor a written statement identifying what portion of the claim is disputed and what portion is undisputed. Any payment due on an undisputed portion of the claim will be processed and made within 60 days after the public entity issues its written statement.

3.10.4.1 If City needs approval from its governing body to provide the Contractor a written statement identifying the disputed portion and the undisputed portion of the claim, and the governing body does not meet within the 45 days or within the mutually agreed to extension of time following receipt of a claim sent by registered mail or certified mail, return receipt requested, City shall have up to three days following the next duly publicly noticed meeting of the governing body after the 45-day period, or extension, expires to provide the Contractor a written statement identifying the disputed portion and the undisputed portion.

3.10.4.2 Within 30 days of receipt of a claim, City may request in writing additional documentation supporting the claim or relating to defenses or claims City may have against the Contractor. If additional information is thereafter required, it shall be requested and provided pursuant to this subdivision, upon mutual agreement of City and the Contractor.

3.10.4.3 City's written response to the claim, as further documented, shall be submitted to the Contractor within 30 days (if the claim is less than \$50,000, within 15 days) after receipt of the further documentation, or within a period of time no greater than that taken by the Contractor in producing the additional information or requested documentation, whichever is greater.

3.10.5 Meet and Confer. If the Contractor disputes City's written response, or City fails to respond within the time prescribed, the Contractor may so notify City, in writing, either within 15 days of receipt of City's response or within 15 days of City's failure to respond within the time prescribed, respectively, and demand an informal conference to meet and confer for settlement of the issues in dispute. Upon receipt of a demand, City shall schedule a meet and confer conference within 30 days for settlement of the dispute.

3.10.6 Mediation. Within 10 business days following the conclusion of the meet and confer conference, if the claim or any portion of the claim remains in dispute, City shall provide the Contractor a written statement identifying the portion of the claim that remains in dispute and the portion that is undisputed. Any payment due on an undisputed portion of the claim shall be processed and made within 60 days after City issues its written statement. Any disputed portion of the claim, as identified by the Contractor in writing, shall be submitted to nonbinding mediation, with City and the Contractor sharing the associated costs equally. City and Contractor shall mutually agree to a mediator within 10 business days after the disputed portion of the claim has been identified in writing, unless the parties agree to select a mediator at a later time.

3.10.6.1 If the Parties cannot agree upon a mediator, each Party shall select a mediator and those mediators shall select a qualified neutral third party to mediate with regard to the disputed portion of the claim. Each Party shall bear the fees and costs charged by its respective mediator in connection with the selection of the neutral mediator.

3.10.6.2 For purposes of this section, mediation includes any nonbinding process, including, but not limited to, neutral evaluation or a dispute review board, in which an independent third party or board assists the Parties in dispute resolution through negotiation or by issuance of an evaluation. Any mediation utilized shall conform to the timeframes in this section.

3.10.6.3 Unless otherwise agreed to by City and the Contractor in writing, the mediation conducted pursuant to this section shall excuse any further obligation under Section 20104.4 to mediate after litigation has been commenced.

3.10.6.4 The mediation shall be held no earlier than the date the Contractor completes the Work or the date that the Contractor last performs Work, whichever is earlier. All unresolved claims shall be considered jointly in a single mediation, unless a new unrelated claim arises after mediation is completed.

3.10.7 Procedures After Mediation. If following the mediation, the claim or any portion remains in dispute, the Contractor must file a claim pursuant to Chapter 1 (commencing with Section 900) and Chapter 2 (commencing with Section 910) of Part 3 of Division 3.6 of Title 1 of the Government Code. For purposes of those provisions, the running of the period of time

within which a claim must be filed shall be tolled from the time the Contractor submits his or her written claim pursuant to subdivision (a) until the time the claim is denied, including any period of time utilized by the meet and confer conference or mediation.

3.10.8 Civil Actions. The following procedures are established for all civil actions filed to resolve claims subject to this Section:

3.10.8.1 Within 60 days, but no earlier than 30 days, following the filing or responsive pleadings, the court shall submit the matter to non-binding mediation unless waived by mutual stipulation of both parties or unless mediation was held prior to commencement of the action in accordance with Public Contract Code section 9204 and the terms of these procedures.. The mediation process shall provide for the selection within 15 days by both parties of a disinterested third person as mediator, shall be commenced within 30 days of the submittal, and shall be concluded within 15 days from the commencement of the mediation unless a time requirement is extended upon a good cause showing to the court.

3.10.8.2 If the matter remains in dispute, the case shall be submitted to judicial arbitration pursuant to Chapter 2.5 (commencing with Section 1141.10) of Title 3 of Part 3 of the Code of Civil Procedure, notwithstanding Section 1114.11 of that code. The Civil Discovery Act of 1986 (Article 3 (commencing with Section 2016) of Chapter 3 of Title 3 of Part 4 of the Code of Civil Procedure) shall apply to any proceeding brought under this subdivision consistent with the rules pertaining to judicial arbitration.

3.10.8.3 In addition to Chapter 2.5 (commencing with Section 1141.10) of Title 3 of Part 3 of the Code of Civil Procedure, (A) arbitrators shall, when possible, be experienced in construction law, and (B) any party appealing an arbitration award who does not obtain a more favorable judgment shall, in addition to payment of costs and fees under that chapter, also pay the attorney's fees on appeal of the other party.

3.10.9 Government Code Claims. In addition to any and all contract requirements pertaining to notices of and requests for compensation or payment for extra work, disputed work, claims and/or changed conditions, Contractor must comply with the claim procedures set forth in Government Code sections 900 et seq. prior to filing any lawsuit against the City. Such Government Code claims and any subsequent lawsuit based upon the Government Code claims shall be limited to those matters that remain unresolved after all procedures pertaining to extra work, disputed work, claims, and/or changed conditions have been followed by Contractor. If no such Government Code claim is submitted, or if any prerequisite contractual requirements are not otherwise satisfied as specified herein, Contractor shall be barred from bringing and maintaining a valid lawsuit against the City. A Government Code claim must be filed no earlier than the date the work is completed or the date the Contractor last performs work on the Project, whichever occurs first. A Government Code claim shall be inclusive of all unresolved claims unless a new unrelated claim arises after the Government Code claim is submitted.

3.10.10 Non-Waiver. City's failure to respond to a claim from the Contractor within the time periods described in this Section or to otherwise meet the time requirements of this Section shall result in the claim being deemed rejected in its entirety. City's failure to respond shall not waive City's rights to any subsequent procedures for the resolution of disputed claims.

3.11 Loss and Damage. Except as may otherwise be limited by law, Contractor shall be responsible for all loss and damage which may arise out of the nature of the Work agreed to herein, or from the action of the elements, or from any unforeseen difficulties which may arise or

be encountered in the prosecution of the Work until the same is fully completed and accepted by City. In the event of damage proximately caused by an Act of God, as defined by Section 7105 of the Public Contract Code, the City may terminate this Contract pursuant to Section 3.17.3; provided, however, that the City needs to provide Contractor with only one (1) day advanced written notice.

3.12 Indemnification.

3.12.1 Scope of Indemnity. To the fullest extent permitted by law, Contractor shall defend, indemnify and hold the City, its officials, employees, agents and authorized volunteers free and harmless from any and all claims, demands, causes of action, suits, actions, proceedings, costs, expenses, liability, judgments, awards, decrees, settlements, loss, damage or injury of any kind, in law or equity, to property or persons, including wrongful death, (collectively, "Claims") in any manner arising out of, pertaining to, or incident to any alleged acts, errors or omissions, or willful misconduct of Contractor, its officials, officers, employees, subcontractors, consultants or agents in connection with the performance of the Contractor's services, the Project or this Agreement, including without limitation the payment of all consequential damages, expert witness fees and attorneys' fees and other related costs and expenses. Notwithstanding the foregoing, to the extent required by Civil Code section 2782, Contractor's indemnity obligation shall not apply to liability for damages for death or bodily injury to persons, injury to property, or any other loss, damage or expense arising from the sole or active negligence or willful misconduct of the City or the City's agents, servants, or independent contractors who are directly responsible to the City, or for defects in design furnished by those persons.

3.12.2 Additional Indemnity Obligations. Contractor shall defend, with counsel of City's choosing and at Contractor's own cost, expense and risk, any and all Claims covered by this section that may be brought or instituted against City or its officials, employees, agents and authorized volunteers. In addition, Contractor shall pay and satisfy any judgment, award or decree that may be rendered against City or its officials, employees, agents and authorized volunteers as part of any such claim, suit, action or other proceeding. Contractor shall also reimburse City for the cost of any settlement paid by City or its officials, employees, agents and authorized volunteers as part of any such claim, suit, action or other proceeding. Such reimbursement shall include payment for City's attorney's fees and costs, including expert witness fees. Contractor shall reimburse City and its officials, employees, agents and authorized volunteers, for any and all legal expenses and costs incurred by each of them in connection therewith or in enforcing the indemnity herein provided. Contractor's obligation to indemnify shall not be restricted to insurance proceeds, if any, received by the City, its officials, employees, agents and authorized volunteers.

3.13 Insurance.

3.13.1 Time for Compliance. Contractor shall not commence Work under this Contract until it has provided evidence satisfactory to the City that it has secured all insurance required under this section. In addition, Contractor shall not allow any subcontractor to commence work on any subcontract until it has provided evidence satisfactory to the City that the subcontractor has secured all insurance required under this section. Failure to provide and maintain all required insurance shall be grounds for the City to terminate this Contract for cause.

3.13.2 Minimum Requirements. Contractor shall, at its expense, procure and maintain for the duration of the Contract insurance against claims for injuries to persons or damages to property which may arise from or in connection with the performance of the Work hereunder by Contractor, its agents, representatives, employees or subcontractors. Contractor

shall also require all of its subcontractors to procure and maintain the same insurance for the duration of the Contract. Such insurance shall meet at least the following minimum levels of coverage:

3.13.2.1 Minimum Scope of Insurance. Coverage shall be at least as broad as the latest version of the following: (1) *General Liability*: Insurance Services Office Commercial General Liability coverage (occurrence form CG 00 01) OR Insurance Services Office Owners and Contractors Protective Liability Coverage Form (CG 00 09 11 88) (coverage for operations of designated contractor); (2) *Automobile Liability*: Insurance Services Office Business Auto Coverage form number CA 00 01, code 1 (any auto); and (3) *Workers' Compensation and Employer's Liability*: Workers' Compensation insurance as required by the State of California and Employer's Liability Insurance. Policies shall not contain exclusions contrary to this Contract.

3.13.2.2 Minimum Limits of Insurance. Contractor shall maintain limits no less than: (1) *General Liability*: \$1,000,000 per occurrence and \$1,000,000 aggregate for bodily injury, personal injury and property damage; (2) *Automobile Liability*: \$1,000,000 per accident for bodily injury and property damage; and (3) *Workers' Compensation and Employer's Liability*: Workers' compensation limits as required by the Labor Code of the State of California. Employer's Liability limits of \$1,000,000 each accident, policy limit bodily injury or disease, and each employee bodily injury or disease. Defense costs shall be available in addition to the limits. Notwithstanding the minimum limits specified herein, any available coverage shall be provided to the parties required to be named as additional insureds pursuant to this Contract.

3.13.3 Insurance Endorsements. The insurance policies shall contain the following provisions, or Contractor shall provide endorsements (amendments) on forms supplied or approved by the City to add the following provisions to the insurance policies:

3.13.3.1 General Liability. (1) Such policy shall give the City, its officials, employees, agents and authorized volunteers additional insured status using ISO endorsements CG20 10 10 01 plus CG20 37 10 01, or endorsements providing the exact same coverage, with respect to the Work or operations performed by or on behalf of Contractor, including materials, parts or equipment furnished in connection with such work; (2) all policies shall waive or shall permit Contractor to waive all rights of subrogation which may be obtained by the Contractor or any insurer by virtue of payment of any loss or any coverage provided to any person named as an additional insured pursuant to this Contract, and Contractor agrees to waive all such rights of subrogation; and (3) the insurance coverage shall be primary insurance as respects the City, its officials, employees, agents and authorized volunteers, or if excess, shall stand in an unbroken chain of coverage excess of Contractor's scheduled underlying coverage. Any insurance or self-insurance maintained by the City, its officials, employees, agents and authorized volunteers shall be excess of Contractor's insurance and shall not be called upon to contribute with it.

3.13.3.2 Automobile Liability. (1) Such policy shall give the City, its officials, employees, agents and authorized volunteers additional insured status with respect to the ownership, operation, maintenance, use, loading or unloading of any auto owned, leased, hired or borrowed by Contractor or for which Contractor is responsible; (2) all policies shall waive or shall permit Contractor to waive all rights of subrogation which may be obtained by the Contractor or any insurer by virtue of payment of any loss or any coverage provided to any person named as an additional insured pursuant to this Contract, and Contractor agrees to waive all such rights of subrogation; and (3) the insurance coverage shall be primary insurance as respects the City, its officials, employees, agents and authorized volunteers, or if excess,

shall stand in an unbroken chain of coverage excess of Contractor's scheduled underlying coverage. Any insurance or self-insurance maintained by the City, its officials, employees, agents and authorized volunteers shall be excess of Contractor's insurance and shall not be called upon to contribute with it in any way.

3.13.3.3 Workers' Compensation and Employer's Liability Coverage. The insurer shall agree to waive all rights of subrogation against the City, its officials, employees, agents and authorized volunteers for losses paid under the terms of the insurance policy which arise from work performed by Contractor.

3.13.3.4 All Coverages. Each insurance policy required by this Contract shall be endorsed to state that: (1) coverage shall not be suspended, voided, reduced or canceled except after thirty (30) days prior written notice by certified mail, return receipt requested, has been given to the City; and (2) any failure to comply with reporting or other provisions of the policies, including breaches of warranties, shall not affect coverage provided to the City, its officials, employees, agents and authorized volunteers.

3.13.4 Separation of Insureds; No Special Limitations. All insurance required by this Section shall contain standard separation of insureds provisions. In addition, such insurance shall not contain any special limitations on the scope of protection afforded to the City, its officials, employees, agents and authorized volunteers.

3.13.5 Deductibles and Self-Insurance Retentions. Any deductibles or self-insured retentions must be declared to and approved by the City. Contractor shall guarantee that, at the option of the City, either: (1) the insurer shall reduce or eliminate such deductibles or self-insured retentions as respects the City, its officials, employees, agents and authorized volunteers; or (2) the Contractor shall procure a bond or other financial guarantee acceptable to the City guaranteeing payment of losses and related investigation costs, claims and administrative and defense expenses.

3.13.6 Acceptability of Insurers. Insurance is to be placed with insurers with a current A.M. Best's rating no less than A:VII, licensed to do business in California, and satisfactory to the City. Exception may be made for the State Compensation Insurance Fund when not specifically rated.

3.13.7 Verification of Coverage. Contractor shall furnish City with original certificates of insurance and endorsements effecting coverage required by this Contract on forms satisfactory to the City. The certificates and endorsements for each insurance policy shall be signed by a person authorized by that insurer to bind coverage on its behalf, and shall be on forms supplied or approved by the City. All certificates and endorsements must be received and approved by the City before work commences. The City reserves the right to require complete, certified copies of all required insurance policies, at any time.

3.13.8 Subcontractors. All subcontractors shall meet the requirements of this Section before commencing Work. Contractor shall furnish separate certificates and endorsements for each subcontractor. Subcontractor policies of General Liability insurance shall name the City, its officials, employees, agents and authorized volunteers as additional insureds using form ISO 20 38 04 13 or endorsements providing the exact same coverage. All coverages for subcontractors shall be subject to all of the requirements stated herein except as otherwise agreed to by the City in writing.

3.13.9 Reporting of Claims. Contractor shall report to the City, in addition to Contractor's insurer, any and all insurance claims submitted by Contractor in connection with the Work under this Contract.

3.14 Bond Requirements.

3.14.1 Payment Bond. If required by law or otherwise specifically requested by City in Exhibit "C" attached hereto and incorporated herein by reference, Contractor shall execute and provide to City concurrently with this Contract a Payment Bond in an amount required by the City and in a form provided or approved by the City. If such bond is required, no payment will be made to Contractor until the bond has been received and approved by the City.

3.14.2 Performance Bond. If specifically requested by City in Exhibit "C" attached hereto and incorporated herein by reference, Contractor shall execute and provide to City concurrently with this Contract a Performance Bond in an amount required by the City and in a form provided or approved by the City. If such bond is required, no payment will be made to Contractor until the bond has been received and approved by the City.

3.14.3 Bond Provisions. Should, in City's sole opinion, any bond become insufficient or any surety be found to be unsatisfactory, Contractor shall renew or replace the effected bond within (ten) 10 days of receiving notice from City. In the event the surety or Contractor intends to reduce or cancel any required bond, at least thirty (30) days prior written notice shall be given to the City, and Contractor shall post acceptable replacement bonds at least ten (10) days prior to expiration of the original bonds. No further payments shall be deemed due or will be made under this Contract until any replacement bonds required by this Section are accepted by the City. To the extent, if any, that the Total Contract Price is increased in accordance with the Contract, Contractor shall, upon request of the City, cause the amount of the bond to be increased accordingly and shall promptly deliver satisfactory evidence of such increase to the City. If Contractor fails to furnish any required bond, the City may terminate the Contract for cause.

3.14.4 Surety Qualifications. Only bonds executed by an admitted surety insurer, as defined in California Code of Civil Procedure Section 995.120, shall be accepted. If a California-admitted surety insurer issuing bonds does not meet these requirements, the insurer will be considered qualified if it is in conformance with Section 995.660 of the California Code of Civil Procedure, and proof of such is provided to the City.

3.15 Warranty. Contractor warrants all Work under the Contract (which for purposes of this Section shall be deemed to include unauthorized work which has not been removed and any non-conforming materials incorporated into the Work) to be of good quality and free from any defective or faulty material and workmanship. Contractor agrees that for a period of one year (or the period of time specified elsewhere in the Contract or in any guarantee or warranty provided by any manufacturer or supplier of equipment or materials incorporated into the Work, whichever is later) after the date of final acceptance, Contractor shall within ten (10) days after being notified in writing by the City of any defect in the Work or non-conformance of the Work to the Contract, commence and prosecute with due diligence all Work necessary to fulfill the terms of the warranty at its sole cost and expense. Contractor shall act sooner as requested by the City in response to an emergency. In addition, Contractor shall, at its sole cost and expense, repair and replace any portions of the Work (or work of other contractors) damaged by its defective Work or which becomes damaged in the course of repairing or replacing defective Work. For any Work so corrected, Contractor's obligation hereunder to correct defective Work shall be reinstated for an additional one year period, commencing with the date of acceptance of such corrected Work. Contractor shall perform such tests as the City may require to verify that

any corrective actions, including, without limitation, redesign, repairs, and replacements comply with the requirements of the Contract. All costs associated with such corrective actions and testing, including the removal, replacement, and reinstatement of equipment and materials necessary to gain access, shall be the sole responsibility of Contractor. All warranties and guarantees of subcontractors, suppliers and manufacturers with respect to any portion of the Work, whether express or implied, are deemed to be obtained by Contractor for the benefit of the City, regardless of whether or not such warranties and guarantees have been transferred or assigned to the City by separate agreement and Contractor agrees to enforce such warranties and guarantees, if necessary, on behalf of the City. In the event that Contractor fails to perform its obligations under this Section, or under any other warranty or guaranty under this Contract, to the reasonable satisfaction of the City, the City shall have the right to correct and replace any defective or non-conforming Work and any work damaged by such work or the replacement or correction thereof at Contractor's sole expense. Contractor shall be obligated to fully reimburse the City for any expenses incurred hereunder upon demand.

3.16 Employee/Labor Certifications.

3.16.1 Contractor's Labor Certification. By its signature hereunder, Contractor certifies that he is aware of the provisions of Section 3700 of the California Labor Code which require every employer to be insured against liability for Worker's Compensation or to undertake self-insurance in accordance with the provisions of that Code, and agrees to comply with such provisions before commencing the performance of the Work. A certification form for this purpose, which is attached to this Contract as Exhibit "D" and incorporated herein by reference, shall be executed simultaneously with this Contract.

3.16.2 Equal Opportunity Employment. Contractor represents that it is an equal opportunity employer and that it shall not discriminate against any employee or applicant for employment because of race, religion, color, national origin, ancestry, sex, age or other interests protected by the State or Federal Constitutions. Such non-discrimination shall include, but not be limited to, all activities related to initial employment, upgrading, demotion, transfer, recruitment or recruitment advertising, layoff or termination.

3.16.3 Verification of Employment Eligibility. By executing this Contract, Contractor verifies that it fully complies with all requirements and restrictions of state and federal law respecting the employment of undocumented aliens, including, but not limited to, the Immigration Reform and Control Act of 1986, as may be amended from time to time, and shall require all subcontractors and sub-subcontractors to comply with the same.

3.17 General Provisions.

3.17.1 City's Representative. The City hereby designates the General Manager, or his or her designee, to act as its representative for the performance of this Contract ("City's Representative"). City's Representative shall have the power to act on behalf of the City for all purposes under this Contract. Contractor shall not accept direction or orders from any person other than the City's Representative or his or her designee.

3.17.2 Contractor's Representative. Before starting the Work, Contractor shall submit in writing the name, qualifications and experience of its proposed representative who shall be subject to the review and approval of the City ("Contractor's Representative"). Following approval by the City, Contractor's Representative shall have full authority to represent and act on behalf of Contractor for all purposes under this Contract. Contractor's Representative shall supervise and direct the Work, using his best skill and attention, and shall be responsible for all construction means, methods, techniques, sequences and procedures and

for the satisfactory coordination of all portions of the Work under this Contract. Contractor's Representative shall devote full time to the Project and either he or his designee, who shall be acceptable to the City, shall be present at the Work site at all times that any Work is in progress and at any time that any employee or subcontractor of Contractor is present at the Work site. Arrangements for responsible supervision, acceptable to the City, shall be made for emergency Work which may be required. Should Contractor desire to change its Contractor's Representative, Contractor shall provide the information specified above and obtain the City's written approval.

3.17.3 Termination. This Contract may be terminated by City at any time, either with or without cause, by giving Contractor three (3) days advance written notice. In the event of termination by City for any reason other than the fault of Contractor, City shall pay Contractor for all Work performed up to that time as provided herein. In the event of breach of the Contract by Contractor, City may terminate the Contract immediately without notice, may reduce payment to Contractor in the amount necessary to offset City's resulting damages, and may pursue any other available recourse against Contractor. Contractor may not terminate this Contract except for cause. In the event this Contract is terminated in whole or in part as provided, City may procure, upon such terms and in such manner as it may determine appropriate, services similar to those terminated. Further, if this Contract is terminated as provided, City may require Contractor to provide all finished or unfinished documents, data, diagrams, drawings, materials or other matter prepared or built by Contractor in connection with its performance of this Contract.

3.17.4 Contract Interpretation. Should any question arise regarding the meaning or import of any of the provisions of this Contract or written or oral instructions from City, the matter shall be referred to City's Representative, whose decision shall be binding upon Contractor.

3.17.5 Anti-Trust Claims. This provision shall be operative if this Contract is applicable to California Public Contract Code Section 7103.5. In entering into this Contract to supply goods, services or materials, Contractor hereby offers and agrees to assign to the City all rights, title, and interest in and to all causes of action it may have under Section 4 of the Clayton Act (15 U.S.C. Section 15) or under the Cartwright Act (Chapter 2, commencing with Section 16700, of Part 2 of Division 7 of the Business and Professions Code) arising from purchases of goods, services, or materials pursuant to the Contract. This assignment shall be made and become effective at the time the City tender final payment to Contractor, without further acknowledgment by the Parties.

3.17.6 Notices. All notices hereunder and communications regarding interpretation of the terms of the Contract or changes thereto shall be provided by the mailing thereof by registered or certified mail, return receipt requested, postage prepaid and addressed as follows:

CONTRACTOR:

Mackone Development, Inc.
2244 Beverly Boulevard
Los Angeles, CA 90057
Attn: Matt Dugan

CITY:

City of Arcadia
240 West Huntington Drive
Arcadia, California 91066
Attn: Carlos Aguilar, General Services Superintendent

Any notice so given shall be considered received by the other Party three (3) days after deposit in the U.S. Mail as stated above and addressed to the Party at the above address. Actual notice shall be deemed adequate notice on the date actual notice occurred, regardless of the method of service.

3.17.7 Time of Essence. Time is of the essence in the performance of this Contract.

3.17.8 Assignment Forbidden. Contractor shall not, either voluntarily or by action of law, assign or transfer this Contract or any obligation, right, title or interest assumed by Contractor herein without the prior written consent of City. If Contractor attempts an assignment or transfer of this Contract or any obligation, right, title or interest herein, City may, at its option, terminate and revoke the Contract and shall thereupon be relieved from any and all obligations to Contractor or its assignee or transferee.

3.17.9 No Third Party Beneficiaries. There are no intended third party beneficiaries of any right or obligation assumed by the Parties.

3.17.10 Laws, Venue, and Attorneys' Fees. This Agreement shall be interpreted in accordance with the laws of the State of California. If any action is brought to interpret or enforce any term of this Agreement, the action shall be brought in a state or federal court situated in the County of Los Angeles, State of California.

3.17.11 Counterparts. This Contract may be executed in counterparts, each of which shall constitute an original.

3.17.12 Successors. The Parties do for themselves, their heirs, executors, administrators, successors, and assigns agree to the full performance of all of the provisions contained in this Contract.

3.17.13 [Reserved]

3.17.14 Solicitation. Contractor maintains and warrants that it has not employed nor retained any company or person, other than a bona fide employee working solely for Contractor, to solicit or secure this Contract. Further, Contractor warrants that it has not paid nor has it agreed to pay any company or person, other than a bona fide employee working solely for Contractor, any fee, commission, percentage, brokerage fee, gift or other consideration contingent upon or resulting from the award or making of this Contract. For breach or violation of this warranty, City shall have the right to terminate this Contract without liability.

3.17.15 Conflict of Interest. Contractor maintains and warrants that it has not employed nor retained any company or person, other than a bona fide employee working solely for Contractor, to solicit or secure this Agreement. Further, Contractor warrants that it has not paid nor has it agreed to pay any company or person, other than a bona fide employee working solely for Contractor, any fee, commission, percentage, brokerage fee, gift or other consideration contingent upon or resulting from the award or making of this Agreement. For

breach or violation of this warranty, City shall have the right to rescind this Agreement without liability. For the term of this Contract, no official, officer or employee of City, during the term of his or her service with City, shall have any direct interest in this Contract, or obtain any present or anticipated material benefit arising therefrom. In addition, Contractor agrees to file, or to cause its employees or subcontractors to file, a Statement of Economic Interest with the City's Filing Officer as required under state law in the performance of the Work.

3.17.16 Certification of License.

3.17.16.1 Contractor certifies that as of the date of execution of this Contract, Contractor has a current contractor's license of the classification indicated below under Contractor's signature.

3.17.16.2 Contractors are required by law to be licensed and regulated by the Contractors' State License Board which has jurisdiction to investigate complaints against contractors if a complaint regarding a patent act or omission is filed within four (4) years of the date of the alleged violation. A complaint regarding a latent act or omission pertaining to structural defects must be filed within ten (10) years of the date of the alleged violation. Any questions concerning a contractor may be referred to the Registrar, Contractors' State License Board, P.O. Box 26000, Sacramento, California 95826.

3.17.17 Authority to Enter Contract. Each Party warrants that the individuals who have signed this Contract have the legal power, right and authority to make this Contract and bind each respective Party.

3.17.18 Entire Contract; Modification. This Contract contains the entire agreement of the Parties with respect to the subject matter hereof, and supersedes all prior negotiations, understandings or agreements. This Contract may only be modified by a writing signed by both Parties.

3.17.19 Non-Waiver. None of the provisions of this Agreement shall be considered waived by either party, unless such waiver is specifically specified in writing.

3.17.20 City's Right to Employ Other Contractors. City reserves right to employ other contractors in connection with this Project or other projects.

[SIGNATURES ON NEXT PAGE]

**SIGNATURE PAGE FOR CONSTRUCTION CONTRACT
BETWEEN THE CITY OF ARCADIA
AND MACKONE DEVELOPMENT, INC.**

IN WITNESS WHEREOF, the Parties have entered into this Agreement as of the _____ day of _____, 2024.

CITY OF ARCADIA

MACKONE DEVELOPMENT, INC.

By: _____
Dominic Lazaretto
City Manager

By: _____
Its: _____

Printed Name: _____

ATTEST:

By: _____

By: _____
City Clerk

Its: _____

Printed Name: _____

APPROVED AS TO FORM:

By: _____
Michael J. Maurer
City Attorney

EXHIBIT "A"

SERVICES / SCHEDULE

The project plan and proposal (Work Order Number 125705.00) are incorporated into this Contract (see attachment "A").

The project plan and proposal (EZIQC Contract No. CA-R8-GB-101723-MDI) are incorporated into this Contract.

EXHIBIT "B"
PLANS AND SPECIFICATIONS

All service and unit specifications are listed in Exhibit "A".

EXHIBIT "C"

SPECIAL CONDITIONS

ARTICLE 1. BONDS

Within ten (10) calendar days from the date the Contractor is notified of award of the Contract, the Contractor shall deliver to the City four identical counterparts of the Performance Bond and Payment Bond on the forms supplied by the City and included as Exhibit "F" to the Contract. Failure to do so may, in the sole discretion of City, result in the forfeiture of Contractor's bid security. The surety supplying the bond must be an admitted surety insurer, as defined in Code of Civil Procedure Section 995.120, authorized to do business as such in the State of California and satisfactory to the City. The Performance Bond and the Payment Bond shall be for one hundred percent (100%) of the Total Contract Price.

EXHIBIT "D"

**CERTIFICATION
LABOR CODE - SECTION 1861**

I, the undersigned Contractor, am aware of the provisions of Section 3700, et seq., of the California Labor Code which require every employer to be insured against liability for Worker's Compensation or to undertake self-insurance in accordance with the provisions of the Code, and I, the undersigned Contractor, agree to and will comply with such provisions before commencing the performance of the Work on this Contract.

MACKONE DEVELOPMENT, INC.

By: _____
Signature

Name (Print)

Title (Print)

EXHIBIT “E”

PUBLIC WORKS CONTRACTOR REGISTRATION CERTIFICATION

Pursuant to Labor Code sections 1725.5 and 1771.1, all contractors and subcontractors that wish to bid on, be listed in a bid proposal, or enter into a contract to perform public work must be registered with the Department of Industrial Relations. See <http://www.dir.ca.gov/Public-Works/PublicWorks.html> for additional information.

No bid will be accepted nor any contract entered into without proof of the contractor’s and subcontractors’ current registration with the Department of Industrial Relations to perform public work.

Contractor hereby certifies that it is aware of the registration requirements set forth in Labor Code sections 1725.5 and 1771.1 and is currently registered as a contractor with the Department of Industrial Relations.¹

Name of Contractor: _____

DIR Registration Number: _____

DIR Registration Expiration: _____

Small Project Exemption: _____ Yes or _____ No

Unless Contractor is exempt pursuant to the small project exemption, Contractor further acknowledges:

- Contractor shall maintain a current DIR registration for the duration of the project.
- Contractor shall include the requirements of Labor Code sections 1725.5 and 1771.1 in its contract with subcontractors and ensure that all subcontractors are registered at the time of bid opening and maintain registration status for the duration of the project.
- Failure to submit this form or comply with any of the above requirements may result in a finding that the bid is non-responsive.

Name of Contractor _____

Signature _____

Name and Title _____

Dated _____

¹ If the Project is exempt from the contractor registration requirements pursuant to the small project exemption under Labor Code Sections 1725.5 and 1771.1, please mark “Yes” in response to “Small Project Exemption.”

EXHIBIT "F"

PAYMENT AND PERFORMANCE BONDS

PERFORMANCE BOND

KNOW ALL PERSONS BY THESE PRESENTS:

THAT WHEREAS, the City of Arcadia (hereinafter referred to as "City") has awarded to **Mackone Development, Inc.**, (hereinafter referred to as the "Contractor") an agreement for **Facilities Exterior Painting Project** (hereinafter referred to as the "Project").

WHEREAS, the work to be performed by the Contractor is more particularly set forth in the Contract Documents for the Project dated _____, (hereinafter referred to as "Contract Documents"), the terms and conditions of which are expressly incorporated herein by reference; and

WHEREAS, the Contractor is required by said Contract Documents to perform the terms thereof and to furnish a bond for the faithful performance of said Contract Documents.

NOW, THEREFORE, we, _____, the undersigned Contractor and _____ as Surety, a corporation organized and duly authorized to transact business under the laws of the State of California, are held and firmly bound unto the City in the sum of **THREE HUNDRED TWENTY-SIX THOUSAND, NINE HUNDRED TWENTY DOLLARS AND THIRTY-THREE CENTS (\$326,920.33)**, said sum being not less than one hundred percent (100%) of the total amount of the Contract, for which amount well and truly to be made, we bind ourselves, our heirs, executors and administrators, successors and assigns, jointly and severally, firmly by these presents.

THE CONDITION OF THIS OBLIGATION IS SUCH, that, if the Contractor, his or its heirs, executors, administrators, successors or assigns, shall in all things stand to and abide by, and well and truly keep and perform the covenants, conditions and agreements in the Contract Documents and any alteration thereof made as therein provided, on its part, to be kept and performed at the time and in the manner therein specified, and in all respects according to their intent and meaning; and shall faithfully fulfill all obligations including the one-year guarantee of all materials and workmanship; and shall indemnify and save harmless the City, its officers and agents, as stipulated in said Contract Documents, then this obligation shall become null and void; otherwise it shall be and remain in full force and effect.

As a condition precedent to the satisfactory completion of the Contract Documents, unless otherwise provided for in the Contract Documents, the above obligation shall hold good for a period of one (1) year after the acceptance of the work by City, during which time if Contractor shall fail to make full, complete, and satisfactory repair and replacements and totally protect the City from loss or damage resulting from or caused by defective materials or faulty workmanship, Surety shall undertake and faithfully fulfill all such obligations. The obligations of Surety hereunder shall continue so long as any obligation of Contractor remains. Nothing herein shall limit the City's rights or the Contractor or Surety's obligations under the Contract, law or equity, including, but not limited to, California Code of Civil Procedure section 337.15.

Whenever Contractor shall be, and is declared by the City to be, in default under the Contract Documents, the Surety shall remedy the default pursuant to the Contract Documents, or shall promptly, at the City's option:

- (1) Take over and complete the Project in accordance with all terms and conditions in the Contract Documents; or

- (2) Obtain a bid or bids for completing the Project in accordance with all terms and conditions in the Contract Documents and upon determination by Surety of the lowest responsive and responsible bidder, arrange for a Contract between such bidder, the Surety and the City, and make available as work progresses sufficient funds to pay the cost of completion of the Project, less the balance of the contract price, including other costs and damages for which Surety may be liable. The term "balance of the contract price" as used in this paragraph shall mean the total amount payable to Contractor by the City under the Contract and any modification thereto, less any amount previously paid by the City to the Contractor and any other set offs pursuant to the Contract Documents.
- (3) Permit the City to complete the Project in any manner consistent with local, California and federal law and make available as work progresses sufficient funds to pay the cost of completion of the Project, less the balance of the contract price, including other costs and damages for which Surety may be liable. The term "balance of the contract price" as used in this paragraph shall mean the total amount payable to Contractor by the City under the Contract and any modification thereto, less any amount previously paid by the City to the Contractor and any other set offs pursuant to the Contract Documents.

Surety expressly agrees that the City may reject any contractor or subcontractor which may be proposed by Surety in fulfillment of its obligations in the event of default by the Contractor.

Surety shall not utilize Contractor in completing the Project nor shall Surety accept a bid from Contractor for completion of the Project if the City, when declaring the Contractor in default, notifies Surety of the City's objection to Contractor's further participation in the completion of the Project.

The Surety, for value received, hereby stipulates and agrees that no change, extension of time, alteration or addition to the terms of the Contract Documents or to the Project to be performed thereunder shall in any way affect its obligations on this bond, and it does hereby waive notice of any such change, extension of time, alteration or addition to the terms of the Contract Documents or to the Project, including but not limited to the provisions of sections 2819 and 2845 of the California Civil Code.

IN WITNESS WHEREOF, we have hereunto set our hands and seals this _____ day of _____, 20__).

(Corporate Seal)

Contractor/ Principal

By _____

Title _____

(Corporate Seal)

Surety

By _____
Attorney-in-Fact

Signatures of those signing for the Contractor and Surety must be notarized and evidence of corporate authority attached.

(Attach Attorney-in-Fact Certificate) Title _____

The rate of premium on this bond is _____ per thousand. The total amount of premium charges, \$_____.
(The above must be filled in by corporate attorney.)

THIS IS A REQUIRED FORM

Any claims under this bond may be addressed to:

(Name and Address of Surety) _____

(Name and Address of Agent or Representative for service of process in California, if different from above) _____

(Telephone number of Surety and Agent or Representative for service of process in California) _____

NOTE: A copy of the Power-of-Attorney authorizing the person signing on behalf of the Surety to do so must be attached hereto.

Notary Acknowledgment

A notary public or other officer completing this certificate verifies only the identity of the individual who signed the document to which this certificate is attached, and not the truthfulness, accuracy, or validity of that document.

STATE OF CALIFORNIA
 COUNTY OF _____

On _____, 20____, before me, _____, Notary Public, personally appeared _____, who proved to me on the basis of satisfactory

evidence to be the person(s) whose name(s) is/are subscribed to the within instrument and acknowledged to me that he/she/they executed the same in his/her/their authorized capacity(ies), and that by his/her/their signature(s) on the instrument the person(s), or the entity upon behalf of which the person(s) acted, executed the instrument.

I certify under PENALTY OF PERJURY under the laws of the State of California that the foregoing paragraph is true and correct.

WITNESS my hand and official seal.

Signature of Notary Public _____

OPTIONAL

Though the information below is not required by law, it may prove valuable to persons relying on the document and could prevent fraudulent removal and reattachment of this form to another document.

CAPACITY CLAIMED BY SIGNER

- Individual
- Corporate Officer

_____ Title(s)

- Partner(s) Limited
- General

- Attorney-In-Fact
- Trustee(s)
- Guardian/Conservator
- Other:

Signer is representing:
 Name Of Person(s) Or Entity(ies)

DESCRIPTION OF ATTACHED DOCUMENT

_____ Title or Type of Document

_____ Number of Pages

_____ Date of Document

_____ Signer(s) Other Than Named Above

PAYMENT BOND

KNOW ALL MEN BY THESE PRESENTS That

WHEREAS, the City of Arcadia (hereinafter designated as the "City"), by action taken or a resolution passed **May 7, 2024**, has awarded to **Mackone Development, Inc.** hereinafter designated as the "Principal," a contract for the work described as follows:

City facilities Exterior Painting Project (the "Project"); and

WHEREAS, the work to be performed by the Principal is more particularly set forth in the Contract Documents for the Project dated _____ ("Contract Documents"), the terms and conditions of which are expressly incorporated by reference; and

WHEREAS, said Principal is required to furnish a bond in connection with said contract; providing that if said Principal or any of its Subcontractors shall fail to pay for any materials, provisions, provender, equipment, or other supplies used in, upon, for or about the performance of the work contracted to be done, or for any work or labor done thereon of any kind, or for amounts due under the Unemployment Insurance Code or for any amounts required to be deducted, withheld, and paid over to the Employment Development Department from the wages of employees of said Principal and its Subcontractors with respect to such work or labor the Surety on this bond will pay for the same to the extent hereinafter set forth.

NOW THEREFORE, we, the Principal and _____ as Surety, are held and firmly bound unto the City in the penal sum of **THREE HUNDRED TWENTY-SIX THOUSAND, NINE HUNDRED TWENTY DOLLARS AND THIRTY-THREE CENTS (\$326,920.33)** lawful money of the United States of America, for the payment of which sum well and truly to be made, we bind ourselves, our heirs, executors, administrators, successors and assigns, jointly and severally, firmly by these presents.

THE CONDITION OF THIS OBLIGATION IS SUCH that if said Principal, his or its subcontractors, heirs, executors, administrators, successors or assigns, shall fail to pay any of the persons named in Section 9100 of the Civil Code, fail to pay for any materials, provisions or other supplies, used in, upon, for or about the performance of the work contracted to be done, or for any work or labor thereon of any kind, or amounts due under the Unemployment Insurance Code with respect to work or labor performed under the contract, or for any amounts required to be deducted, withheld, and paid over to the Employment Development Department or Franchise Tax Board from the wages of employees of the contractor and his subcontractors pursuant to Section 18663 of the Revenue and Taxation Code, with respect to such work and labor the Surety or Sureties will pay for the same, in an amount not exceeding the sum herein above specified.

This bond shall inure to the benefit of any of the persons named in Section 9100 of the Civil Code so as to give a right of action to such persons or their assigns in any suit brought upon this bond.

It is further stipulated and agreed that the Surety on this bond shall not be exonerated or released from the obligation of this bond by any change, extension of time for performance, addition, alteration or modification in, to, or of any contract, plans, specifications, or agreement pertaining or relating to any scheme or work of improvement herein above described, or pertaining or relating to the furnishing of labor, materials, or equipment therefore, nor by any change or modification of any terms of payment or extension of the time for any payment pertaining or relating to any scheme or work of improvement herein above described, nor by any

rescission or attempted rescission of the contract, agreement or bond, nor by any conditions precedent or subsequent in the bond attempting to limit the right of recovery of claimants otherwise entitled to recover under any such contract or agreement or under the bond, nor by any fraud practiced by any person other than the claimant seeking to recover on the bond and that this bond be construed most strongly against the Surety and in favor of all persons for whose benefit such bond is given, and under no circumstances shall Surety be released from liability to those for whose benefit such bond has been given, by reason of any breach of contract between the owner or City and original contractor or on the part of any obligee named in such bond, but the sole conditions of recovery shall be that claimant is a person described in Section 9100 of the Civil Code, and has not been paid the full amount of his claim and that Surety does hereby waive notice of any such change, extension of time, addition, alteration or modification herein mentioned and the provisions of sections 2819 and 2845 of the California Civil Code.

IN WITNESS WHEREOF, we have hereunto set our hands and seals this _____ day of _____, 20__.

(Corporate Seal)

Contractor/ Principal

By _____

Title _____

(Corporate Seal)

Surety

By _____
Attorney-in-Fact

Title _____

Signatures of those signing for the Contractor and Surety must be notarized and evidence of corporate authority attached. A Power-of-Attorney authorizing the person signing on behalf of the Surety to do so must be attached hereto.

NOTE: A copy of the Power-of-Attorney authorizing the person signing on behalf of the Surety to do so must be attached hereto.

Notary Acknowledgment

A notary public or other officer completing this certificate verifies only the identity of the individual who signed the document to which this certificate is attached, and not the truthfulness, accuracy, or validity of that document.

STATE OF CALIFORNIA
 COUNTY OF _____

On _____, 20____, before me, _____, Notary Public, personally appeared _____, who proved to me on the basis of satisfactory

evidence to be the person(s) whose name(s) is/are subscribed to the within instrument and acknowledged to me that he/she/they executed the same in his/her/their authorized capacity(ies), and that by his/her/their signature(s) on the instrument the person(s), or the entity upon behalf of which the person(s) acted, executed the instrument.

I certify under PENALTY OF PERJURY under the laws of the State of California that the foregoing paragraph is true and correct.

WITNESS my hand and official seal.

Signature of Notary Public _____

OPTIONAL

Though the information below is not required by law, it may prove valuable to persons relying on the document and could prevent fraudulent removal and reattachment of this form to another document.

CAPACITY CLAIMED BY SIGNER

- Individual
- Corporate Officer

_____ Title(s)

- Partner(s) Limited
- General

- Attorney-In-Fact
- Trustee(s)
- Guardian/Conservator
- Other:

Signer is representing:
 Name Of Person(s) Or Entity(ies)

DESCRIPTION OF ATTACHED DOCUMENT

_____ Title or Type of Document

_____ Number of Pages

_____ Date of Document

_____ Signer(s) Other Than Named Above

EXHIBIT "G"
FEDERAL REQUIREMENTS

NOT APPLICABLE.



STAFF REPORT

Fire Department

DATE: May 7, 2024

TO: Honorable Mayor and City Council

FROM: Chen Suen, Fire Chief

SUBJECT: PROFESSIONAL SERVICES AGREEMENT WITH FIRE FACILITIES, INC. FOR DESIGN SERVICES FOR THE ARCADIA AND UNITED STATES FOREST SERVICE JOINT TRAINING CENTER IN THE AMOUNT OF \$60,000

CEQA: Not a Project

Recommendation: Approve

SUMMARY

The City is investigating a joint project with the United States Forest Service (“USFS”) to build a joint training center (Training Center) located at the Angeles Forest Service Headquarters Station, 701 N. Santa Anita Ave. The Training Center will fill a critical need in the region by providing an ideal setting to train first responders in the area and bolster inter-agency emergency response. The Training Center will also provide a much-needed, dedicated training space for Arcadia firefighters and specifically enable training to respond to an urbanizing downtown core.

Fire Facilities, Inc. is the sole source supplier of Wesco Steel Fire Training Towers and Westec Insulation Systems, which is the preferred vendor for the proposed training structures. Therefore, it is recommended that the City Council approve, authorize, and direct the City Manager to execute a Professional Services Agreement with Fire Facilities, Inc. for design services for the Arcadia and USFS Joint Training Center, in the amount of \$60,000.

BACKGROUND

The mission of the Arcadia Fire Department is to deliver necessary services that minimize the loss of life and property threatened by the hazards of fire, medical and rescue emergencies, hazardous materials incidents, and disaster situations in the community. Over time, the scope and responsibility of the Fire Department has expanded and evolved into a more complex operation, encompassing an all-hazard, all-risk approach to emergency response. As the City continues to grow, the complexity of taller, denser developments with higher-occupancy loads will require a greater

emphasis on quality, advanced training. A dedicated training space is needed to meet this growing demand.

Currently, the Fire Department utilizes various areas throughout Arcadia to conduct its training. Locations such as the City's Public Works Yard located behind Fire Station 107, and various parking structures in the City have provided an acceptable space for training. However, these areas do not provide a realistic space that mimics true emergencies. Additionally, the Fire Department currently shares a joint training center with Monrovia Fire that is located at 2055 S. Myrtle Ave., in Monrovia. The use of this joint training center with Monrovia creates complications due to its location outside of City borders. For instance, when multiple crews train on a single scenario, most or all of Arcadia's fire response personnel are outside of City borders, which can significantly affect response times, if a call occurs during the training. This results either in a loss of service, or a need to call in other agencies to cover the community while training happens. This limits the City's ability to conduct this type of large-scale training, which is critical to readiness. Further, because of the small footprint of the Monrovia Training Center, the types of training that can be conducted is limited. The small footprint of the Monrovia Training Center is especially challenging for multicompany trainings that use multiple apparatus, requiring a larger space. Although there is an existing agreement between Monrovia and Arcadia that is set to expire in June 2024, primary control of the tower respective to scheduling, maintenance, and upgrade decisions rests with Monrovia.

DISCUSSION

The 2020 Bobcat Fire further emphasized the need and importance of inter-agency training and cooperation, especially with the USFS. The proposed project will meet this need. An existing training agreement is in place with the USFS at their headquarters site in the center of Arcadia. Currently, the Fire Department uses and maintains several training props, including simulated roof props for ventilation training and areas used for confined space rescues. This project would entail an expansion of this site with some additional improvements. The specific area that the proposed Training Center would be built on measures approximately 30,000 square feet and is an unimproved dirt lot. The Fire Department has engaged in advanced discussions with the USFS on the special use permitting of the location. USFS Angeles Forest Chief Robert Garcia and his staff have provided their verbal support for the project.

The proposed project would include a four-story training tower with live fire training capabilities and classroom space. There would also be a residential simulation element integrated within the training tower that allows firefighters to deploy hose lines and simulate rescues in a residential environment. These elements also provide opportunities for a more expansive variety of training exercises that include laddering, search and rescue, rappelling, roof operations, and high-angle rescue operations.

After researching several options for training structures, Wesco Steel Fire Training Towers provided the greatest flexibility of design and function. The design of the structure will incorporate features, options, and layouts that are specifically matched to meet this City's current and future needs. Unique to Wesco Steel Fire Training Towers is its Westec Insulation System, which is used in the live-burn room that provides unprecedented protection for the fire training structure. As a result of this insulation system, burn rooms are provided with the industry's best 15-year limited warranty. Additionally, Fire Facilities Inc. has produced over 500 training towers that are in use nationwide and in several foreign countries. Each tower was designed and engineered specifically for local and regional site conditions. Fire Facilities, Inc. is the sole provider for both the Wesco Steel Fire Training Towers and the Westec Insulation System.

Extensive research was also conducted on various potential funding sources and opportunities for the Training Center. After meeting with various offices of elected officials, it is apparent that projects that are identified as "shovel-ready" would be prioritized over others that were not. A commitment to the design phase of the Training Center would bolster the City's application for funding for various grant opportunities at the federal, state, and local levels. Additionally, the design phase will assist the City in costing of the project. The Fire Facilities Inc.'s expertise in producing a suitable blueprint for the Joint Training Center's design will help establish the foundational phase of the project.

ENVIRONMENTAL ANALYSIS

The Professional Services Agreement with Fire Facilities, Inc. is only to authorize design drawings to be completed, and therefore, does not constitute a project under Section 15061(b)(3) of the California Environmental Quality Act ("CEQA") Guidelines, as it can be seen with certainty that it will have no impact on the environment.

FISCAL IMPACT

The total cost for the design of the Arcadia and USFS Joint Training Center is \$60,000. Sufficient funds are currently available in the Fire Protection Facilities Development Impact Fee Fund ("Fire Impact Fee"). The Fire Impact Fee was approved by City Council on May 2, 2023, and was established in response to the Citizen's Financial Advisory Committee's recommendation for ensuring future funding for expanding community needs. Specifically, the Fire Impact Fee was adopted to ease the financial burdens associated with increased service levels from new development. Having a facility that allows for simulations and training in the types of buildings being constructed in the Downtown will advance this goal.

The initial estimated cost of the Training Center is \$2,256,000, which includes the \$60,000 design services that are proposed in this report. The Fire Department will

continue to seek grant funds through various sources to fund the remaining costs of this project.

RECOMMENDATION

It is recommended that the City Council determine that this action does not constitute a project under the California Environmental Quality Act ("CEQA"); and approve, authorize, and direct the City Manager to execute a Professional Services Agreement with Fire Facilities, Inc. for design services for the Arcadia and United States Forest Service Joint Training Center in the amount of \$60,000.

Approved:



Dominic Lazzaretto
City Manager

Attachments: Sole Source Letter for Wesco Towers
Proposed Professional Services Agreement



To Whom It May Concern:

For over 20 years, Fire Facilities, Inc.[®] has been the sole source supplier of Wesco[®] Steel Fire Training Towers. Wesco training towers are manufactured here in the United States, and made from American steel products. To date, Fire Facilities Inc. has produced over 500 training towers that are in use throughout 48 U.S. States, and 16 foreign countries! Each tower is designed and engineered specifically to local and regional site conditions.

Fire Facilities understands the need to provide firefighters with a training environment that will give them the skills that will be used on a daily basis, especially on the fire-ground. Firefighters are constantly required to respond to unknown situations that will call upon their related experiences, knowledge and training. The development and continued maintenance of their skills will play an important role in the overall success of each firefighter and on the department as a whole.

Wesco Steel Fire Training Towers by Fire Facilities allow the greatest flexibility of design and function. The design of the structure will incorporate features, options and layouts that are specifically matched to meet the department's current and future needs. Not only will the structure serve for training for physical tasks, it will also create an environment that will aid in the development of fire officers and can be used to challenge officers working to master the Incident Command System, in a controlled environment. The structure will be able to adapt and change to the department's requirements, thereby providing necessary training for the department into the future.

Fire Facilities' experience encompasses designing fire-training structures for departments throughout the United States and abroad, including our nation's military. We have the ability to develop systems that work within the structure to simulate several fire types and situations using either Class 'A' materials, or highly advanced natural gas or propane fueled systems. The structure will be engineered to meet or exceed applicable NFPA and OSHA standards and allow for realism in all aspects of live fire training. We draw upon our experience to provide the most comprehensive live fire training structures, while maintaining a controlled environment for safe, effective training.

All Wesco Steel Fire Training Towers by Fire Facilities feature the Westec[™] Insulation System. Westec is a system developed exclusively by Fire Facilities, Inc., for use in live-burn room applications and is protected by **US Patent Number 7,823,357 B2**. This state of the art system provides unprecedented protection for the fire training structure. Westec Systems are provided with the industry's best 15-Year Limited Warranty for burn rooms! The Westec System withstands continuous burn room temperatures of 1850° F. The system greatly extends the life of the burn room and reduces ongoing maintenance costs. Fire Facilities is pleased to be the Sole Provider of the Westec System.*



Other design features **exclusive** to Fire Facilities training structures include sculpted trims to prevent injury and damage to equipment; safe training floor decks, with a flat, slip-resistant profile made from galvanealed steel; an 18 gauge flat siding profile that is safe, strong and aesthetically pleasing designed to withstand the forces of rappelling and laddering the structure; custom made burn room doors, and shutters that will withstand the rigors of a fire-training environment, and our patented movable wall partition system to enable the reconfiguration of the tower layout and create temporary rooms and hallways and vary the training scenarios for realistic ongoing training.

Respectfully,

Steven Harms
Regional Manager
Fire Facilities, Inc.

**(For firefighter safety, Fire Facilities recommends maximum training temperatures of 1200 °F.)*

**CITY OF ARCADIA
PROFESSIONAL SERVICES AGREEMENT**

This Agreement is made and entered into as of _____, 20____ by and between the City of Arcadia, a municipal corporation organized and operating under the laws of the State of California with its principal place of business at 240 West Huntington Drive, Arcadia, California 91066 (“City”), and **Fire Facilities, Inc., a CORPORATION**, with its principal place of business at **314 Wilburn Road, Sun Prairie, WI 53590** (hereinafter referred to as “Consultant”). City and Consultant are sometimes individually referred to as “Party” and collectively as “Parties” in this Agreement.

RECITALS

A. City is a public agency of the State of California and is in need of professional services for the following project:

Engineering and Design Services for a custom Fire Facilities “FF-3” Deputy Chief model training tower. (hereinafter referred to as “the Project”).

B. Consultant is duly licensed and has the necessary qualifications to provide such services.

C. The Parties desire by this Agreement to establish the terms for City to retain Consultant to provide the services described herein.

AGREEMENT

NOW, THEREFORE, IT IS AGREED AS FOLLOWS:

1. Services.

Consultant shall provide the City with the services described in the **Scope of Services** attached hereto **as Exhibit “A,” Proposal for Engineering and Design Services.**

2. Compensation.

a. Subject to paragraph 2(b) below, the City shall pay for such services in accordance with **the Schedule of Charges set forth in Exhibit “B**

b. In no event shall the total amount paid for services rendered by Consultant under this Agreement exceed the sum **of sixty thousand dollars (\$60,000)**. This amount is to cover all printing and related costs, and the City will not pay any additional fees for printing expenses. Periodic payments shall be made within 30 days of receipt of an invoice which includes a detailed description of the work performed. Payments to Consultant for work performed will be made on a monthly billing basis.

3. Additional Work.

If changes in the work seem merited by Consultant or the City, and informal consultations with the other party indicate that a change is warranted, it shall be processed in the following manner: a letter outlining the changes shall be forwarded to the City by Consultant with a statement of estimated changes in fee or time schedule. An amendment to this Agreement shall

be prepared by the City and executed by both Parties before performance of such services, or the City will not be required to pay for the changes in the scope of work. Such amendment shall not render ineffective or invalidate unaffected portions of this Agreement.

4. Maintenance of Records.

Books, documents, papers, accounting records, and other evidence pertaining to costs incurred shall be maintained by Consultant and made available at all reasonable times during the contract period and for four (4) years from the date of final payment under the contract for inspection by City.

5. [Insert Term or Time of Performance].

[If engaging the Consultant for a particular term, use the following provision]

The term of this Agreement shall be from **[Insert start date]** to **[Insert end date]**, unless earlier terminated as provided herein. The Parties may, by mutual, written consent, extend the term of this Agreement if necessary to complete the Project. Consultant shall perform its services in a prompt and timely manner within the term of this Agreement and shall commence performance upon receipt of written notice from the City to proceed (“Notice to Proceed”). **[If the City has specific milestones or timelines for performance, please input those requirements in the “Activity Schedule” attached as Exhibit C, otherwise delete Exhibit C.]** The Notice to Proceed shall set forth the date of commencement of work.

[If engaging the Consultant to perform a discrete task with a specified deadline, use the following provision]

Consultant shall perform its services in a prompt and timely manner and shall commence performance upon receipt of written notice from the City to proceed (“Notice to Proceed”). Consultant shall complete the services required hereunder within **[Insert number of calendar days for performance of the services – if more detail is required attach “Activity Schedule” as Exhibit C, otherwise delete Exhibit C.]** The Notice to Proceed shall set forth the date of commencement of work.

6. Delays in Performance.

a. Neither City nor Consultant shall be considered in default of this Agreement for delays in performance caused by circumstances beyond the reasonable control of the non-performing party. For purposes of this Agreement, such circumstances include but are not limited to, abnormal weather conditions; floods; earthquakes; fire; epidemics; war; riots and other civil disturbances; strikes, lockouts, work slowdowns, and other labor disturbances; sabotage or judicial restraint.

b. Should such circumstances occur, the non-performing party shall, within a reasonable time of being prevented from performing, give written notice to the other party describing the circumstances preventing continued performance and the efforts being made to resume performance of this Agreement.

7. Compliance with Law.

a. Consultant shall comply with all applicable laws, ordinances, codes and regulations of the federal, state and local government, including Cal/OSHA requirements.

b. If required, Consultant shall assist the City, as requested, in obtaining and maintaining all permits required of Consultant by federal, state and local regulatory agencies.

c. If applicable, Consultant is responsible for all costs of clean up and/ or removal of hazardous and toxic substances spilled as a result of his or her services or operations performed under this Agreement.

8. Standard of Care

Consultant's services will be performed in accordance with generally accepted professional practices and principles and in a manner consistent with the level of care and skill ordinarily exercised by members of the profession currently practicing under similar conditions.

9. Assignment and Subconsultant

Consultant shall not assign, sublet, or transfer this Agreement or any rights under or interest in this Agreement without the written consent of the City, which may be withheld for any reason. Any attempt to so assign or so transfer without such consent shall be void and without legal effect and shall constitute grounds for termination. Subcontracts, if any, shall contain a provision making them subject to all provisions stipulated in this Agreement. Nothing contained herein shall prevent Consultant from employing independent associates, and subconsultants as Consultant may deem appropriate to assist in the performance of services hereunder.

10. Independent Contractor

Consultant is retained as an independent contractor and is not an employee of City. No employee or agent of Consultant shall become an employee of City. The work to be performed shall be in accordance with the work described in this Agreement, subject to such directions and amendments from City as herein provided.

11. Insurance. Consultant shall not commence work for the City until it has provided evidence satisfactory to the City it has secured all insurance required under this section. In addition, Consultant shall not allow any subcontractor to commence work on any subcontract until it has secured all insurance required under this section.

a. Commercial General Liability

(i) The Consultant shall take out and maintain, during the performance of all work under this Agreement, in amounts not less than specified herein, Commercial General Liability Insurance, in a form and with insurance companies acceptable to the City.

(ii) Coverage for Commercial General Liability insurance shall be at least as broad as the following:

(1) Insurance Services Office Commercial General Liability coverage (Occurrence Form CG 00 01) or exact equivalent.

(iii) Commercial General Liability Insurance must include coverage for the following:

(1) Bodily Injury and Property Damage

- (2) Personal Injury/Advertising Injury
- (3) Premises/Operations Liability
- (4) Products/Completed Operations Liability
- (5) Aggregate Limits that Apply per Project
- (6) Explosion, Collapse and Underground (UCX) exclusion deleted
- (7) Contractual Liability with respect to this Agreement
- (8) Property Damage
- (9) Independent Consultants Coverage

(iv) The policy shall contain no endorsements or provisions limiting coverage for (1) contractual liability; (2) cross liability exclusion for claims or suits by one insured against another; (3) products/completed operations liability; or (4) contain any other exclusion contrary to the Agreement.

(v) The policy shall give City, its officials, officers, employees, agents and City designated volunteers additional insured status using ISO endorsement forms CG 20 10 10 01 and 20 37 10 01, or endorsements providing the exact same coverage.

(vi) The general liability program may utilize either deductibles or provide coverage excess of a self-insured retention, subject to written approval by the City, and provided that such deductibles shall not apply to the City as an additional insured.

b. Automobile Liability

(i) At all times during the performance of the work under this Agreement, the Consultant shall maintain Automobile Liability Insurance for bodily injury and property damage including coverage for owned, non-owned and hired vehicles, in a form and with insurance companies acceptable to the City.

(ii) Coverage for automobile liability insurance shall be at least as broad as Insurance Services Office Form Number CA 00 01 covering automobile liability (Coverage Symbol 1, any auto).

(iii) The policy shall give City, its officials, officers, employees, agents and City designated volunteers additional insured status.

(iv) Subject to written approval by the City, the automobile liability program may utilize deductibles, provided that such deductibles shall not apply to the City as an additional insured, but not a self-insured retention.

c. Workers' Compensation/Employer's Liability

(i) Consultant certifies that he/she is aware of the provisions of Section 3700 of the California Labor Code which requires every employer to be insured against liability for workers' compensation or to undertake self-insurance in accordance with the provisions of that code, and he/she will comply with such provisions before commencing work under this Agreement.

(ii) To the extent Consultant has employees at any time during the term of this Agreement, at all times during the performance of the work under this Agreement, the Consultant shall maintain full compensation insurance for all persons employed directly by

him/her to carry out the work contemplated under this Agreement, all in accordance with the "Workers' Compensation and Insurance Act," Division IV of the Labor Code of the State of California and any acts amendatory thereof, and Employer's Liability Coverage in amounts indicated herein. Consultant shall require all subconsultants to obtain and maintain, for the period required by this Agreement, workers' compensation coverage of the same type and limits as specified in this section.

d. Professional Liability (Errors and Omissions)

At all times during the performance of the work under this Agreement the Consultant shall maintain professional liability or Errors and Omissions insurance appropriate to its profession, in a form and with insurance companies acceptable to the City and in an amount indicated herein. This insurance shall be endorsed to include contractual liability applicable to this Agreement and shall be written on a policy form coverage specifically designed to protect against acts, errors or omissions of the Consultant. "Covered Professional Services" as designated in the policy must specifically include work performed under this Agreement. The policy must "pay on behalf of" the insured and must include a provision establishing the insurer's duty to defend.

e. Minimum Policy Limits Required

(i) The following insurance limits are required for the Agreement:

Combined Single Limit

Commercial General Liability	\$1,000,000 per occurrence/ \$2,000,000 aggregate for bodily injury, personal injury, and property damage
Automobile Liability	\$1,000,000 per occurrence for bodily injury and property damage
Employer's Liability	\$1,000,000 per occurrence
Professional Liability	\$1,000,000 per claim and aggregate (errors and omissions)

(ii) Defense costs shall be payable in addition to the limits.

(iii) Requirements of specific coverage or limits contained in this section are not intended as a limitation on coverage, limits, or other requirement, or a waiver of any coverage normally provided by any insurance. Any available coverage shall be provided to the parties required to be named as Additional Insured pursuant to this Agreement.

f. Evidence Required

Prior to execution of the Agreement, the Consultant shall file with the City evidence of insurance from an insurer or insurers certifying to the coverage of all insurance required herein. Such evidence shall include original copies of the ISO CG 00 01 (or insurer's equivalent) signed by the insurer's representative and Certificate of Insurance (Acord Form 25-S or equivalent), together with required endorsements. All evidence of insurance shall be signed by a properly authorized officer, agent, or qualified representative of the insurer and shall certify the names of the insured, any additional insureds, where appropriate, the type and amount of the

insurance, the location and operations to which the insurance applies, and the expiration date of such insurance.

g. Policy Provisions Required

(i) Consultant shall provide the City at least thirty (30) days prior written notice of cancellation of any policy required by this Agreement, except that the Consultant shall provide at least ten (10) days prior written notice of cancellation of any such policy due to non-payment of premium. If any of the required coverage is cancelled or expires during the term of this Agreement, the Consultant shall deliver renewal certificate(s) including the General Liability Additional Insured Endorsement to the City at least ten (10) days prior to the effective date of cancellation or expiration.

(ii) The Commercial General Liability Policy and Automobile Policy shall each contain a provision stating that Consultant's policy is primary insurance and that any insurance, self-insurance or other coverage maintained by the City or any named insureds shall not be called upon to contribute to any loss.

(iii) The retroactive date (if any) of each policy is to be no later than the effective date of this Agreement. Consultant shall maintain such coverage continuously for a period of at least three years after the completion of the work under this Agreement. Consultant shall purchase a one (1) year extended reporting period A) if the retroactive date is advanced past the effective date of this Agreement; B) if the policy is cancelled or not renewed; or C) if the policy is replaced by another claims-made policy with a retroactive date subsequent to the effective date of this Agreement.

(iv) All required insurance coverages, except for the professional liability coverage, shall contain or be endorsed to waiver of subrogation in favor of the City, its officials, officers, employees, agents, and volunteers or shall specifically allow Consultant or others providing insurance evidence in compliance with these specifications to waive their right of recovery prior to a loss. Consultant hereby waives its own right of recovery against City, and shall require similar written express waivers and insurance clauses from each of its subconsultants.

(v) The limits set forth herein shall apply separately to each insured against whom claims are made or suits are brought, except with respect to the limits of liability. Further the limits set forth herein shall not be construed to relieve the Consultant from liability in excess of such coverage, nor shall it limit the Consultant's indemnification obligations to the City and shall not preclude the City from taking such other actions available to the City under other provisions of the Agreement or law.

h. Qualifying Insurers

(i) All policies required shall be issued by acceptable insurance companies, as determined by the City, which satisfy the following minimum requirements:

(1) Each such policy shall be from a company or companies with a current A.M. Best's rating of no less than A:VII and admitted to transact in the business of insurance in the State of California, or otherwise allowed to place insurance through surplus line brokers under applicable provisions of the California Insurance Code or any federal law.

i. Additional Insurance Provisions

(i) The foregoing requirements as to the types and limits of insurance coverage to be maintained by Consultant, and any approval of said insurance by the City, is not intended to and shall not in any manner limit or qualify the liabilities and obligations otherwise assumed by the Consultant pursuant to this Agreement, including but not limited to, the provisions concerning indemnification.

(ii) If at any time during the life of the Agreement, any policy of insurance required under this Agreement does not comply with these specifications or is canceled and not replaced, City has the right but not the duty to obtain the insurance it deems necessary and any premium paid by City will be promptly reimbursed by Consultant or City will withhold amounts sufficient to pay premium from Consultant payments. In the alternative, City may cancel this Agreement.

(iii) The City may require the Consultant to provide complete copies of all insurance policies in effect for the duration of the Project.

(iv) Neither the City nor any of its officials, officers, employees, agents or volunteers shall be personally responsible for any liability arising under or by virtue of this Agreement.

j. Subconsultant Insurance Requirements. Consultant shall not allow any subcontractors or subconsultants to commence work on any subcontract until they have provided evidence satisfactory to the City that they have secured all insurance required under this section. Policies of commercial general liability insurance provided by such subcontractors or subconsultants shall be endorsed to name the City as an additional insured using ISO form CG 20 38 04 13 or an endorsement providing the exact same coverage. If requested by Consultant, City may approve different scopes or minimum limits of insurance for particular subcontractors or subconsultants.

12. Indemnification.

a. To the fullest extent permitted by law, Consultant shall defend (with counsel of City's choosing), indemnify and hold the City, its officials, officers, employees, volunteers, and agents free and harmless from any and all claims, demands, causes of action, costs, expenses, liability, loss, damage or injury of any kind, in law or equity, to property or persons, including wrongful death, in any manner arising out of, pertaining to, or incident to any acts, errors or omissions, or willful misconduct of Consultant, its officials, officers, employees, subcontractors, consultants or agents in connection with the performance of the Consultant's services, the Project or this Agreement, including without limitation the payment of all damages, expert witness fees and attorney's fees and other related costs and expenses. Consultant's obligation to indemnify shall not be restricted to insurance proceeds, if any, received by Consultant, the City, its officials, officers, employees, agents, or volunteers.

b. To the extent required by Civil Code section 2782.8, which is fully incorporated herein, Consultant's obligations under the above indemnity shall be limited to claims that arise out of, pertain to, or relate to the negligence, recklessness, or willful misconduct of the Consultant, but shall not otherwise be reduced. If Consultant's obligations to defend, indemnify, and/or hold harmless arise out of Consultant's performance of "design professional services" (as that term is defined under Civil Code section 2782.8), then upon Consultant obtaining a final

adjudication that liability under a claim is caused by the comparative active negligence or willful misconduct of the City, Consultant's obligations shall be reduced in proportion to the established comparative liability of the City and shall not exceed the Consultant's proportionate percentage of fault.

13. California Labor Code Requirements.

a. Consultant is aware of the requirements of California Labor Code Sections 1720 et seq. and 1770 et seq., which require the payment of prevailing wage rates and the performance of other requirements on certain "public works" and "maintenance" projects ("Prevailing Wage Laws"). If the services are being performed as part of an applicable "public works" or "maintenance" project, as defined by the Prevailing Wage Laws, and if the total compensation is \$15,000 or more for maintenance or \$25,000 or more for construction, alteration, demolition, installation, or repair, Consultant agrees to fully comply with such Prevailing Wage Laws. Consultant shall defend, indemnify and hold the City, its officials, officers, employees and agents free and harmless from any claims, liabilities, costs, penalties or interest arising out of any failure or alleged failure to comply with the Prevailing Wage Laws. It shall be mandatory upon the Consultant and all subconsultants to comply with all California Labor Code provisions, which include but are not limited to prevailing wages (Labor Code Sections 1771, 1774 and 1775), employment of apprentices (Labor Code Section 1777.5), certified payroll records (Labor Code Sections 1771.4 and 1776), hours of labor (Labor Code Sections 1813 and 1815) and debarment of contractors and subcontractors (Labor Code Section 1777.1).

b. If the services are being performed as part of an applicable "public works" or "maintenance" project and if the total compensation is \$15,000 or more for maintenance or \$25,000 or more for construction, alteration, demolition, installation, or repair, then pursuant to Labor Code Sections 1725.5 and 1771.1, the Consultant and all subconsultants performing such services must be registered with the Department of Industrial Relations. Consultant shall maintain registration for the duration of the Project and require the same of any subconsultants, as applicable. This Project may also be subject to compliance monitoring and enforcement by the Department of Industrial Relations. It shall be Consultant's sole responsibility to comply with all applicable registration and labor compliance requirements.

c. This Agreement may also be subject to compliance monitoring and enforcement by the Department of Industrial Relations. It shall be Consultant's sole responsibility to comply with all applicable registration and labor compliance requirements. Any stop orders issued by the Department of Industrial Relations against Consultant or any subcontractor that affect Consultant's performance of services, including any delay, shall be Consultant's sole responsibility. Any delay arising out of or resulting from such stop orders shall be considered Consultant caused delay and shall not be compensable by the City. Consultant shall defend, indemnify and hold the City, its officials, officers, employees and agents free and harmless from any claim or liability arising out of stop orders issued by the Department of Industrial Relations against Consultant or any subcontractor.

14. Verification of Employment Eligibility.

By executing this Agreement, Consultant verifies that it fully complies with all requirements and restrictions of state and federal law respecting the employment of undocumented aliens, including, but not limited to, the Immigration Reform and Control Act of 1986, as may be amended from time to time, and shall require all subconsultants and sub-subconsultants to comply with the same.

[Delete the following provision and renumber all further provisions, if not applicable.]

15. City Material Requirements.

Consultant is hereby made aware of the City's requirements regarding materials, as set forth in **[Insert the name of the document that contains the City's standard material requirements]**, which are deemed to be a part of this Agreement.

16. Laws and Venue.

This Agreement shall be interpreted in accordance with the laws of the State of California. If any action is brought to interpret or enforce any term of this Agreement, the action shall be brought in a state or federal court situated in the County of Los Angeles, State of California.

17 Termination or Abandonment

a. City has the right to terminate or abandon any portion or all of the work under this Agreement by giving ten (10) calendar days written notice to Consultant. In such event, City shall be immediately given title and possession to all original field notes, drawings and specifications, written reports and other documents produced or developed for that portion of the work completed and/or being abandoned. City shall pay Consultant the reasonable value of services rendered for any portion of the work completed prior to termination. If said termination occurs prior to completion of any task for the Project for which a payment request has not been received, the charge for services performed during such task shall be the reasonable value of such services, based on an amount mutually agreed to by City and Consultant of the portion of such task completed but not paid prior to said termination. City shall not be liable for any costs other than the charges or portions thereof which are specified herein. Consultant shall not be entitled to payment for unperformed services, and shall not be entitled to damages or compensation for termination of work.

b. Consultant may terminate its obligation to provide further services under this Agreement upon thirty (30) calendar days' written notice to City only in the event of substantial failure by City to perform in accordance with the terms of this Agreement through no fault of Consultant.

18 Documents. Except as otherwise provided in "Termination or Abandonment," above, all original field notes, written reports, Drawings and Specifications and other documents, produced or developed for the Project shall, upon payment in full for the services described in this Agreement, be furnished to and become the property of the City.

19. Organization

Consultant shall assign **Steven Harms as Project Manager**. The Project Manager shall not be removed from the Project or reassigned without the prior written consent of the City.

20. Limitation of Agreement.

This Agreement is limited to and includes only the work included in the Project described above.

21. Notice

Any notice or instrument required to be given or delivered by this Agreement may be given or delivered by depositing the same in any United States Post Office, certified mail, return receipt requested, postage prepaid, addressed to:

CITY:

City of Arcadia
240 West Huntington Drive
Arcadia, CA 91066

Attn: **Capt. Richard Olivarez,**
Fire Department

CONSULTANT:

Fire Facilities, Inc.
314 Wilburn Road
Sun Prairie, WI 53590

Attn: Steven Harms

and shall be effective upon receipt thereof.

22. Third Party Rights

Nothing in this Agreement shall be construed to give any rights or benefits to anyone other than the City and the Consultant.

23. Equal Opportunity Employment.

Consultant represents that it is an equal opportunity employer and that it shall not discriminate against any employee or applicant for employment because of race, religion, color, national origin, ancestry, sex, age or other interests protected by the State or Federal Constitutions. Such non-discrimination shall include, but not be limited to, all activities related to initial employment, upgrading, demotion, transfer, recruitment or recruitment advertising, layoff or termination.

24. Entire Agreement

This Agreement, with its exhibits, represents the entire understanding of City and Consultant as to those matters contained herein, and supersedes and cancels any prior or contemporaneous oral or written understanding, promises or representations with respect to those matters covered hereunder. Each party acknowledges that no representations, inducements, promises or agreements have been made by any person which are not incorporated herein, and that any other agreements shall be void. This Agreement may not be modified or altered except in writing signed by both Parties hereto. This is an integrated Agreement.

25. Severability

The unenforceability, invalidity or illegality of any provision(s) of this Agreement shall not render the provisions unenforceable, invalid or illegal.

26. Successors and Assigns

This Agreement shall be binding upon and shall inure to the benefit of the successors in interest, executors, administrators and assigns of each party to this Agreement. However, Consultant shall not assign or transfer by operation of law or otherwise any or all of its rights,

burdens, duties or obligations without the prior written consent of City. Any attempted assignment without such consent shall be invalid and void.

27. Non-Waiver

None of the provisions of this Agreement shall be considered waived by either party, unless such waiver is specifically specified in writing.

28. Time of Essence

Time is of the essence for each and every provision of this Agreement.

29. City's Right to Employ Other Consultants

City reserves its right to employ other consultants, including engineers, in connection with this Project or other projects.

30. Prohibited Interests

Consultant maintains and warrants that it has not employed nor retained any company or person, other than a bona fide employee working solely for Consultant, to solicit or secure this Agreement. Further, Consultant warrants that it has not paid nor has it agreed to pay any company or person, other than a bona fide employee working solely for Consultant, any fee, commission, percentage, brokerage fee, gift or other consideration contingent upon or resulting from the award or making of this Agreement. For breach or violation of this warranty, City shall have the right to rescind this Agreement without liability. For the term of this Agreement, no director, official, officer or employee of City, during the term of his or her service with City, shall have any direct interest in this Agreement, or obtain any present or anticipated material benefit arising therefrom.

31. Federal Requirements *****INCLUDE THIS SECTION ONLY IF APPLICABLE; DELETE OTHERWISE AND DELETE ASSOCIATED EXHIBIT. YOU MAY ALSO NEED TO INCLUDE SOME INFORMATION IN THE RFP DUE TO FEDERAL FUNDING GUIDELINES. CONSULT LEGAL COUNSEL IF NECESSARY*****

When funding for the services is provided, in whole or in part, by an agency of the federal government, Consultant shall also fully and adequately comply with the provisions included in Exhibit "D" (Federal Requirements) attached hereto and incorporated herein by reference ("Federal Requirements"). With respect to any conflict between such Federal Requirements and the terms of this Agreement and/or the provisions of state law, the more stringent requirement shall control.

[SIGNATURES ON FOLLOWING PAGE]

**SIGNATURE PAGE FOR PROFESSIONAL SERVICES AGREEMENT
BETWEEN THE CITY OF ARCADIA
AND FIRE FACILITIES, INC.**

IN WITNESS WHEREOF, the Parties have executed this Agreement as of the date first written above.

CITY OF ARCADIA

FIRE FACILITIES, INC.

By: _____
Dominic Lazzaretto
Fire Chief

By: _____
Its: _____
Printed Name: _____

ATTEST:

By: _____
City Clerk

APPROVED AS TO FORM:

By: _____
City Attorney

EXHIBIT A

Scope of Services

Fire Facilities Inc. (Seller), proposes to provide (3) three sets of civil engineer's stamped tower drawings and (3) three sets of the civil engineer's stamped tower calculations for a structural steel fire-training prop, also known as a "fire training tower", as referenced below for the Arcadia Fire Department in Arcadia, CA. The drawings/calculations are to be created in advance of manufacturing or shipping the finished materials/product for submittal review purposes to the customer or customer's representative. The customer or customer's representative then submits directly to the local building department/plan review for approval process. The training prop's structural design shall incorporate the *2022 California Building Code* and it is also understood that this training prop will not meet all criteria of buildings intended to accommodate occupancy and will be considered a nonbuilding structure for code compliance and load interpretation as stated in our specifications (dated April 23, 2024) in section 2.3 and 2.4.

Reference:

Base Model Type: Wesco FF-3, "Deputy Chief"
Custom Drawings #5585, Pages 1-4, (floor plans & elevations)
Drawings Dated: April 23, 2024
Specification Dated: April 23, 2024

Important Notes:

1. Since Fire Facilities Inc. is not the Coordinating Design Professional/Engineer of Record, FFI does not submit for approval, permits, or provide inspections of any type.
2. FFI is not a CA Structural Engineer, only a Civil, if S.E. is required, S.E. to be provided by others.
3. This fire training simulator shall be classified as a nonbuilding structure for structural design (i.e., seismic resisting system, load interpretation, etc.) and as an unoccupied structure for life/fire/safety. The price above reflects these stipulations and must be approved by the local plan reviewer before design work can begin.
4. Required approvals for the stairs, railings, and ladders are by others. Any changes to the tower or the preceding items, due to these approvals, will incur additional money/change orders.
5. Interior and exterior stairs/railings meet CA building code requirements except for the items called out in section 2.4 of the attached specifications. Variance, if required, is by others - any additional requirements/changes will incur an additional change order.
6. Special inspections for fabrication are by others - fabrication takes place in Wisconsin.
7. Any required testing or special inspections/observations are by others.
8. To enable the design to proceed, the customer must provide a Geo-technical Soil Report for the proposed tower location, or indicate that FFI can assume that the Soils Site Class is "Site Class-D" or better.
9. Electrical/lighting layouts, site work, and drainage designs and materials to be provided by others.

EXHIBIT B

Schedule of Charges/Payments

The aforementioned services is for a total cost of \$60,000. Consultant will inform City regarding any out-of-scope work being performed by Consultant.

- Buyer will be invoiced at the time of completion of engineering work. Full payment for the design services shall be made to Fire Facilities inc. with Net-30 terms.
- This agreement assumes that revisions, if any, will be limited to required design modifications as per building department review. Any modifications that include adding or removing of components will result in added Change Order fees which are to be paid in addition to the fees mentioned above.

DRAFT

EXHIBIT C
Activity Schedule

The Scope of Services shall be completed within the term of contract.

DRAFT

EXHIBIT D
Federal Requirements

DRAFT



STAFF REPORT

Public Works Services Department

DATE: May 7, 2024

TO: Honorable Mayor and City Council

FROM: Paul Cranmer, Public Works Services Director
By: Carlos Aguilar, General Services Superintendent

SUBJECT: CONTRACT WITH EXPRESS ENERGY SERVICES, INC. FOR THE REPAIR UNDERGROUND FIELD LIGHTING SHORT PROJECT IN THE AMOUNT OF \$38,872.76

CEQA: Exempt

Recommendation: Approve

SUMMARY

The Fiscal Year 2023-24 Capital Improvement Program (“CIP”) budget provides for the repair of the underground electrical short at the Dana Middle School athletic field. Utilizing Sourcewell, a national cooperative purchasing program, enables the City to streamline the process of procuring electrical wiring material and electrical installation services at the best price possible. It is recommended that the City Council approve, authorize, and direct the City Manager to execute a contract with Express Energy Services, Inc. for the Repair Underground Field Lighting Short Project in the amount of \$38,872.76.

BACKGROUND

The City of Arcadia has a Joint Maintenance Agreement (“Agreement”) with the Arcadia Unified School District for facilities at Dana Middle School, which includes the shared maintenance of the athletic field to allow the field’s public use. The Agreement indicates that the City, at its sole cost and expense, will maintain the athletic field lighting at Dana Field. The Fiscal Year 2023-24 CIP budget provides for the repair of the underground electrical short at the Dana Middle School athletic field. The existing electrical wiring that runs underground from the electrical panel to the athletic field light pole has an electrical short and is not able to provide power to the pole. To avoid any property damage caused by a malfunctioning electrical system and to provide proper lighting to the field, the electrical short at the athletic field will be repaired.

DISCUSSION

As part of this project, the circuit will be isolated and the damaged components causing the short circuit will be repaired or replaced. This could involve repairing damaged wires, tightening loose connections, replacing blown fuses, or replacing damaged breakers. Once the short has been addressed, a certified electrician will test the circuits to ensure all connections are secure and verify that all lighting is restored to normal operations.

Utilizing Sourcewell, a national cooperative purchasing program, enables the City to streamline the procurement process for these services at a lower cost than the traditional competitive bidding process. The California Government Code authorizes public agencies to participate in cooperative purchasing agreements such as those established by Sourcewell, while remaining within the City's adopted rules and procedures for purchasing. Sourcewell awarded a contract to Express Energy Services, Inc. for a series of specialized electrical construction services, including those needed for the repair of the underground field lighting short. A copy of the agreement between Sourcewell and Express Energy Services, Inc. is attached. The bidding process and the contract have been reviewed by the Public Works Services Department and meet the City's procurement requirements.

ENVIRONMENTAL ANALYSIS

This Project is considered a Class 1 exemption as defined in Section 15301(a) "Existing Facilities" projects of the California Environmental Quality Act ("CEQA"), which exempts projects consisting of alterations to existing facilities involving such things as electrical conveyances.

FISCAL IMPACT

The Agreement with the Arcadia Unified School District indicates that the City, at its sole cost and expense, will maintain the athletic field lighting at Dana Field. The total cost for the Repair Underground Field Lighting Short Project is \$38,872.76, with funds in the amount of \$46,000 budgeted in the Fiscal Year 2023-24 Capital Improvement Program.

RECOMMENDATION

It is recommended that the City Council determine that this project is a Class 1 exemption under the California Environmental Quality Act ("CEQA"); and approve, authorize, and direct the City Manager to execute a contract with Express Energy Services, Inc. for the Repair Underground Field Lighting Short Project in the amount of \$38,872.76.

Approved:

Dominic Lazzaretto
City Manager

Attachments: Sourcewell Contract
Proposed Construction Contract



Indefinite Delivery-Indefinite Quantity Construction Contract

Contract Number: CA-R10-E-101723-EES

Service Type: Electrical

This Indefinite Delivery-Indefinite Quantity Construction Contract (Contract) is between **Sourcewell**, 202 12th Street Northeast, P.O. Box 219, Staples, MN 56479 and **Express Energy Services Inc., 2719 W Lincoln Ave, Anaheim, CA 92801** (Contractor).

Sourcewell is a State of Minnesota local government agency and service cooperative created under the laws of the State of Minnesota (Minnesota Statutes Section 123A.21) that offers cooperative procurement solutions to government entities. Participation is open to federal, state and municipal governmental entities, K-12 and higher education entities, nonprofit entities, tribal governments, and other public entities located within the United States.

The Contractor desires to contract with Sourcewell to provide construction services to entities that access Sourcewell's indefinite delivery-indefinite quantity (IDIQ) construction contracts within the Service Region.

I. TERM OF CONTRACT

A. EFFECTIVE DATE. This Contract, including the General Terms and Conditions incorporated by reference, is effective upon the later of December 6, 2023 or the date of the final signature below.

B. EXPIRATION DATE AND EXTENSION. This Contract expires **December 5, 2024**, unless it is terminated sooner pursuant to Article XX of the General Terms and Conditions, which are incorporated into this Contract by reference. This Contract allows up to five additional one-year extensions upon the request of Sourcewell and written agreement with Contractor. Sourcewell retains the right to consider additional extensions beyond six years as required under exceptional circumstances.

II. REGION AND SERVICES

The Contractor's Region is: Region 10. The Contractor's IDIQ construction service type is: Electrical. The Contractor **has** agreed to perform work outside the Region.

III. ADJUSTMENT FACTORS

The Contractor will perform any or all Tasks in the Construction Task Catalog for the Unit Price appearing therein multiplied by the following Adjustment Factors. See the General Terms and Conditions for additional information.

A. **Normal Working Hours – Prevailing Wage Rate Projects**: Work performed from 7:00 a.m. until 4:00 p.m. Monday to Friday, except Holidays. The Contractor will perform Tasks during Normal Working Hours for the Unit Price set forth in the CTC multiplied by the Adjustment Factor of: 1.1500.

B. **Other Than Normal Working Hours – Prevailing Wage Rate Projects:** Work performed from 4:00 p.m. to 7:00 a.m. Monday to Friday, and any time Saturday, Sunday and Holidays. The Contractor will perform Tasks during Other Than Normal Working Hours for the Unit Price set forth in the CTC multiplied by the Adjustment Factor of: 1.2200.

C. **Secured Facilities/OSHPD Prevailing - Wage Rate Projects:** Work performed from 7:00 a.m. until 4:00 p.m. Monday to Friday, except Holidays. The Contractor will perform Tasks during Normal Working Hours for the Unit Price set forth in the CTC multiplied by the Adjustment Factor of: 1.2500.

D. **All Union Wage Projects:** Work performed from 7:00 a.m. until 4:00 p.m. Monday to Friday, except Holidays. The Contractor will perform Tasks during Normal Working Hours for the Unit Price set forth in the CTC multiplied by the Adjustment Factor of: 1.1500.

E. **Non pre-priced Adjustment Factor:** To be applied to Work determined not to be included in the CTC but within the general scope of the work: 1.1000.

VI. AUTHORIZED REPRESENTATIVE

A. Sourcewell's Authorized Representative is its Chief Procurement Officer.

B. The Contractor's Authorized Representative is Donald Rivers. If the Contractor's Authorized Representative changes at any time during this Contract, Contractor must promptly notify Sourcewell in writing.

Sourcewell

Express Energy Services Inc.

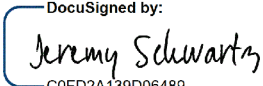
DocuSigned by:

C0FD2A139D06489...
By: _____

DocuSigned by:

D4EB468FCE6F4C1...
By: _____

Jeremy Schwartz

Donald Rivers

Title: Chief Procurement Officer

Title: CEO & Owner

Date: 12/20/2023 | 6:48 AM CST

Date: 12/20/2023 | 5:12 AM CST

**CITY OF ARCADIA
CONSTRUCTION CONTRACT
REPAIR UNDERGROUND FIELD LIGHTING SHORT
AT DANA MIDDLE SCHOOL ATHLETIC FIELD PROJECT**

1. PARTIES AND DATE.

This Contract is made and entered into this _____ day of _____, 2024 by and between the City of Arcadia, a public agency of the State of California (“City”) and **Express Energy Services, Inc.**, a California Corporation, with its principal place of business at **10610 Humbolt Street, Los Alamitos, CA 90720** (“Contractor”). City and Contractor are sometimes individually referred to as “Party” and collectively as “Parties” in this Contract.

2. RECITALS.

2.1 City. City is a public agency organized under the laws of the State of California, with power to contract for services necessary to achieve its purpose.

2.2 Contractor. Contractor desires to perform and assume responsibility for the provision of certain construction services required by the City on the terms and conditions set forth in this Contract. Contractor represents that it is duly licensed and experienced in providing **electrical** related construction services to public clients, that it and its employees or subcontractors have all necessary licenses and permits to perform the services in the State of California, and that it is familiar with the plans of City. The following license classifications are required for this Project: **C-10**.

2.3 Project. City desires to engage Contractor to render such services for the **Repair Underground Field Lighting Short at Dana Middle School Athletic Field Project** (“Project”) as set forth in this Contract.

2.4 Project Documents & Certifications. Contractor has obtained, and delivers concurrently herewith, a performance bond, a payment bond, and all insurance documentation, as required by the Contract.

3. TERMS

3.1 Incorporation of Documents. This Contract includes and hereby incorporates in full by reference the following documents, including all exhibits, drawings, specifications and documents therein, and attachments and addenda thereto:

- Services/Schedule (Exhibit “A”)
- Plans and Specifications (Exhibit “B”)
- Special Conditions (Exhibit “C”)
- Contractor’s Certificate Regarding Workers’ Compensation (Exhibit “D”)
- Public Works Contractor Registration Certification (Exhibit “E”)
- Payment and Performance Bonds (Exhibit “F”)
- Federal Requirements (Exhibit “G”)
- Addenda
- Change Orders executed by the City
- Current Edition of the Standard Specifications for Public Works Construction (The Greenbook), Excluding Sections 1-9

- Notice Inviting Bids, if any
- Instructions to Bidders, if any
- Contractor's Bid

3.2 Contractor's Basic Obligation; Scope of Work. Contractor promises and agrees, at its own cost and expense, to furnish to the City all labor, materials, tools, equipment, services, and incidental and customary work necessary to fully and adequately complete the Project, including all structures and facilities necessary for the Project or described in the Contract (hereinafter sometimes referred to as the "Work"), for a Total Contract Price as specified pursuant to this Contract. All Work shall be subject to, and performed in accordance with the above referenced documents, as well as the exhibits attached hereto and incorporated herein by reference. The plans and specifications for the Work are further described in Exhibit "B" attached hereto and incorporated herein by this reference. Special Conditions, if any, relating to the Work are described in Exhibit "C" attached hereto and incorporated herein by this reference.

3.2.1 Change in Scope of Work. Any change in the scope of the Work, method of performance, nature of materials or price thereof, or any other matter materially affecting the performance or nature of the Work shall not be paid for or accepted unless such change, addition or deletion is approved in writing by a valid change order executed by the City. Should Contractor request a change order due to unforeseen circumstances affecting the performance of the Work, such request shall be made within five (5) business days of the date such circumstances are discovered or shall waive its right to request a change order due to such circumstances. If the Parties cannot agree on any change in price required by such change in the Work, the City may direct the Contractor to proceed with the performance of the change on a time and materials basis.

3.2.2 Substitutions/"Or Equal". Pursuant to Public Contract Code Section 3400(b), the City may make a finding that designates certain products, things, or services by specific brand or trade name. Unless specifically designated in this Contract, whenever any material, process, or article is indicated or specified by grade, patent, or proprietary name or by name of manufacturer, such Specifications shall be deemed to be used for the purpose of facilitating the description of the material, process or article desired and shall be deemed to be followed by the words "or equal."

Contractor may, unless otherwise stated, offer for substitution any material, process or article which shall be substantially equal or better in every respect to that so indicated or specified in this Contract. However, the City may have adopted certain uniform standards for certain materials, processes and articles. Contractor shall submit requests, together with substantiating data, for substitution of any "or equal" material, process or article no later than thirty-five (35) days after award of the Contract. To facilitate the construction schedule and sequencing, some requests may need to be submitted before thirty-five (35) days after award of Contract. Provisions regarding submission of "or equal" requests shall not in any way authorize an extension of time for performance of this Contract. If a proposed "or equal" substitution request is rejected, Contractor shall be responsible for providing the specified material, process or article. The burden of proof as to the equality of any material, process or article shall rest with Contractor.

The City has the complete and sole discretion to determine if a material, process or article is an "or equal" material, process or article that may be substituted. Data required to substantiate requests for substitutions of an "or equal" material, process or article data shall include a signed affidavit from Contractor stating that, and describing how, the substituted "or

equal” material, process or article is equivalent to that specified in every way except as listed on the affidavit. Substantiating data shall include any and all illustrations, specifications, and other relevant data including catalog information which describes the requested substituted “or equal” material, process or article, and substantiates that it is an “or equal” to the material, process or article. The substantiating data must also include information regarding the durability and lifecycle cost of the requested substituted “or equal” material, process or article. Failure to submit all the required substantiating data, including the signed affidavit, to the City in a timely fashion will result in the rejection of the proposed substitution.

Contractor shall bear all of the City’s costs associated with the review of substitution requests. Contractor shall be responsible for all costs related to a substituted “or equal” material, process or article. Contractor is directed to the Special Conditions (if any) to review any findings made pursuant to Public Contract Code section 3400.

3.3 Period of Performance and Liquidated Damages. Contractor shall perform and complete all Work under this Contract within **Fourteen (14) calendar** days, beginning the effective date of the Notice to Proceed (“Contract Time”). Contractor shall perform its Work in strict accordance with any completion schedule, construction schedule or project milestones developed by the City. Such schedules or milestones may be included as part of Exhibits “A” or “B” attached hereto, or may be provided separately in writing to Contractor. Contractor agrees that if such Work is not completed within the aforementioned Contract Time and/or pursuant to any such completion schedule, construction schedule or project milestones developed pursuant to provisions of the Contract, it is understood, acknowledged and agreed that the City will suffer damage. Pursuant to Government Code Section 53069.85, Contractor shall pay to the City as fixed and liquidated damages the sum of **One hundred Fifty Dollars and No Cents (\$150.00) per day** for each and every calendar day of delay beyond the Contract Time or beyond any completion schedule, construction schedule or Project milestones established pursuant to the Contract.

3.4 Standard of Performance; Performance of Employees. Contractor shall perform all Work under this Contract in a skillful and workmanlike manner, and consistent with the standards generally recognized as being employed by professionals in the same discipline in the State of California. Contractor represents and maintains that it is skilled in the professional calling necessary to perform the Work. Contractor warrants that all employees and subcontractors shall have sufficient skill and experience to perform the Work assigned to them. Finally, Contractor represents that it, its employees and subcontractors have all licenses, permits, qualifications and approvals of whatever nature that are legally required to perform the Work, including any required business license, and that such licenses and approvals shall be maintained throughout the term of this Contract. As provided for in the indemnification provisions of this Contract, Contractor shall perform, at its own cost and expense and without reimbursement from the City, any work necessary to correct errors or omissions which are caused by Contractor’s failure to comply with the standard of care provided for herein. Any employee who is determined by the City to be uncooperative, incompetent, a threat to the safety of persons or the Work, or any employee who fails or refuses to perform the Work in a manner acceptable to the City, shall be promptly removed from the Project by Contractor and shall not be re-employed on the Work.

3.5 Control and Payment of Subordinates; Contractual Relationship. City retains Contractor on an independent contractor basis and Contractor is not an employee of City. Any additional personnel performing the work governed by this Contract on behalf of Contractor shall at all times be under Contractor’s exclusive direction and control. Contractor shall pay all wages, salaries, and other amounts due such personnel in connection with their performance

under this Contract and as required by law. Contractor shall be responsible for all reports and obligations respecting such additional personnel, including, but not limited to: social security taxes, income tax withholding, unemployment insurance, and workers' compensation insurance.

3.6 City's Basic Obligation. City agrees to engage and does hereby engage Contractor as an independent contractor to furnish all materials and to perform all Work according to the terms and conditions herein contained for the sum set forth above. Except as otherwise provided in the Contract, the City shall pay to Contractor, as full consideration for the satisfactory performance by Contractor of the services and obligations required by this Contract, the below-referenced compensation in accordance with compensation provisions set forth in the Contract.

3.7 Compensation and Payment.

3.7.1 Amount of Compensation. As consideration for performance of the Work required herein, City agrees to pay Contractor the Total Contract Price of **THIRTY-EIGHT THOUSAND, EIGHT HUNDRED SEVENTY-TWO DOLLARS AND SEVENTY-SIX CENTS (\$38,872.76)** ("Total Contract Price") provided that such amount shall be subject to adjustment pursuant to the applicable terms of this Contract or written change orders approved and signed in advance by the City.

3.7.2 Payment of Compensation. If the Work is scheduled for completion in thirty (30) or less calendar days, City will arrange for payment of the Total Contract Price upon completion and approval by City of the Work. If the Work is scheduled for completion in more than thirty (30) calendar days, City will pay Contractor on a monthly basis as provided for herein. On or before the fifth (5th) day of each month, Contractor shall submit to the City an itemized application for payment in the format supplied by the City indicating the amount of Work completed since commencement of the Work or since the last progress payment. These applications shall be supported by evidence which is required by this Contract and such other documentation as the City may require. The Contractor shall certify that the Work for which payment is requested has been done and that the materials listed are stored where indicated. Contractor may be required to furnish a detailed schedule of values upon request of the City and in such detail and form as the City shall request, showing the quantities, unit prices, overhead, profit, and all other expenses involved in order to provide a basis for determining the amount of progress payments.

3.7.3 Prompt Payment. City shall review and pay all progress payment requests in accordance with the provisions set forth in Section 20104.50 of the California Public Contract Code. However, no progress payments will be made for Work not completed in accordance with this Contract. Contractor shall comply with all applicable laws, rules and regulations relating to the proper payment of its employees, subcontractors, suppliers or others.

3.7.4 Contract Retentions. From each approved progress estimate, five percent (5%) will be deducted and retained by the City, and the remainder will be paid to Contractor. All Contract retention shall be released and paid to Contractor and subcontractors pursuant to California Public Contract Code Section 7107.

3.7.5 Other Retentions. In addition to Contract retentions, the City may deduct from each progress payment an amount necessary to protect City from loss because of: (1) liquidated damages which have accrued as of the date of the application for payment; (2) any sums expended by the City in performing any of Contractor's obligations under the Contract which Contractor has failed to perform or has performed inadequately; (3) defective Work not remedied; (4) stop notices as allowed by state law; (5) reasonable doubt that the Work can be

completed for the unpaid balance of the Total Contract Price or within the scheduled completion date; (6) unsatisfactory prosecution of the Work by Contractor; (7) unauthorized deviations from the Contract; (8) failure of Contractor to maintain or submit on a timely basis proper and sufficient documentation as required by the Contract or by City during the prosecution of the Work; (9) erroneous or false estimates by Contractor of the value of the Work performed; (10) any sums representing expenses, losses, or damages as determined by the City, incurred by the City for which Contractor is liable under the Contract; and (11) any other sums which the City is entitled to recover from Contractor under the terms of the Contract or pursuant to state law, including Section 1727 of the California Labor Code. The failure by the City to deduct any of these sums from a progress payment shall not constitute a waiver of the City's right to such sums.

3.7.6 Substitutions for Contract Retentions. In accordance with California Public Contract Code Section 22300, the City will permit the substitution of securities for any monies withheld by the City to ensure performance under the Contract. At the request and expense of Contractor, securities equivalent to the amount withheld shall be deposited with the City, or with a state or federally chartered bank in California as the escrow agent, and thereafter the City shall then pay such monies to Contractor as they come due. Upon satisfactory completion of the Contract, the securities shall be returned to Contractor. For purposes of this Section and Section 22300 of the Public Contract Code, the term "satisfactory completion of the contract" shall mean the time the City has issued written final acceptance of the Work and filed a Notice of Completion as required by law and provisions of this Contract. Contractor shall be the beneficial owner of any securities substituted for monies withheld and shall receive any interest thereon. The escrow agreement used for the purposes of this Section shall be in the form provided by the City.

3.7.7 Title to Work. As security for partial, progress, or other payments, title to Work for which such payments are made shall pass to the City at the time of payment. To the extent that title has not previously been vested in the City by reason of payments, full title shall pass to the City at delivery of the Work at the destination and time specified in this Contract. Such transferred title shall in each case be good, free and clear from any and all security interests, liens, or other encumbrances. Contractor promises and agrees that it will not pledge, hypothecate, or otherwise encumber the items in any manner that would result in any lien, security interest, charge, or claim upon or against said items. Such transfer of title shall not imply acceptance by the City, nor relieve Contractor from the responsibility to strictly comply with the Contract, and shall not relieve Contractor of responsibility for any loss of or damage to items.

3.7.8 Labor and Material Releases. Contractor shall furnish City with labor and material releases from all subcontractors performing work on, or furnishing materials for, the Work governed by this Contract prior to final payment by City.

3.7.9 Prevailing Wages. Contractor is aware of the requirements of California Labor Code Section 1720 et seq., and 1770 et seq., as well as California Code of Regulations, Title 8, Section 16000 et seq., ("Prevailing Wage Laws"), which require the payment of prevailing wage rates and the performance of other requirements on "public works" and "maintenance" projects. Since the Services are being performed as part of an applicable "public works" or "maintenance" project, as defined by the Prevailing Wage Laws, and if the total compensation is \$25,000 or more, Contractor agrees to fully comply with such Prevailing Wage Laws. City shall provide Contractor with a copy of the prevailing rates of per diem wages in effect at the commencement of this Contract. Contractor shall make copies of the prevailing rates of per diem wages for each craft, classification or type of worker needed to execute the

Services available to interested parties upon request, and shall post copies at Contractor's principal place of business and at the project site. Contractor shall defend, indemnify and hold the City, its officials, officers, employees and agents free and harmless from any claim or liability arising out of any failure or alleged failure to comply with the Prevailing Wage Laws. Contractor and any subcontractor shall forfeit a penalty of up to \$200 per calendar day or portion thereof for each worker paid less than the prevailing wage rates.

3.7.10 Apprenticeable Crafts. If the Total Contract Price exceeds \$35,000 and if Contractor employs workmen in an apprenticeable craft or trade, Contractor shall comply with the provisions of Section 1777.5 of the California Labor Code with respect to the employment of properly registered apprentices upon public works. The primary responsibility for compliance with said section for all apprenticeable occupations shall be with Contractor. The Contractor or any subcontractor that is determined by the Labor Commissioner to have knowingly violated Section 1777.5 shall forfeit as a civil penalty an amount not exceeding \$100 for each full calendar day of noncompliance, or such greater amount as provided by law.

3.7.11 Hours of Work. If the Total Contract Price exceeds \$25,000, Contractor is advised that eight (8) hours labor constitutes a legal day's work. Pursuant to Section 1813 of the California Labor Code, Contractor shall forfeit a penalty of \$25.00 per worker for each day that each worker is permitted to work more than eight (8) hours in any one calendar day and forty (40) hours in any one calendar week, except when payment for overtime is made at not less than one and one-half (1-1/2) times the basic rate for that worker.

3.7.12 Payroll Records. If the Total Contract Price exceeds \$25,000, Contractor and each subcontractor shall keep an accurate payroll record, showing the name, address, social security number, work classification, straight time and overtime hours worked each day and week, and the actual per diem wages paid to each journeyman, apprentice, worker, or other employee employed by him or her in connection with the public work. The payroll records shall be certified and shall be available for inspection at all reasonable hours at the principal office of Contractor in the manner provided in Labor Code section 1776. In the event of noncompliance with the requirements of this section, Contractor shall have 10 days in which to comply subsequent to receipt of written notice specifying in what respects such Contractor must comply with this section. Should noncompliance still be evident after such 10-day period, Contractor shall, as a penalty to City, forfeit not more than \$100.00 for each calendar day or portion thereof, for each worker, until strict compliance is effectuated. The amount of the forfeiture is to be determined by the Labor Commissioner. A contractor who is found to have violated the provisions of law regarding wages on Public Works with the intent to defraud shall be ineligible to bid on Public Works contracts for a period of one to three years as determined by the Labor Commissioner. Upon the request of the Division of Apprenticeship Standards or the Division of Labor Standards Enforcement, such penalties shall be withheld from progress payments then due. The responsibility for compliance with this section is on Contractor. The requirement to submit certified payroll records directly to the Labor Commissioner under Labor Code section 1771.4 shall not apply to work performed on a public works project that is exempt pursuant to the small project exemption specified in Labor Code Section 1771.4.

3.7.13 Contractor and Subcontractor Registration. If the Total Contract Price exceeds \$25,000, then pursuant to Labor Code sections 1725.5 and 1771.1, all contractors and subcontractors that wish to bid on, be listed in a bid proposal, or enter into a contract to perform public work must be registered with the Department of Industrial Relations. No bid will be accepted nor any contract entered into without proof of the contractor's and subcontractors' current registration with the Department of Industrial Relations to perform public work. Contractor is directed to review, fill out and execute the Public Works Contractor Registration

Certification attached hereto as Exhibit "E" prior to contract execution. Notwithstanding the foregoing, the contractor registration requirements mandated by Labor Code Sections 1725.5 and 1771.1 shall not apply to work performed on a public works project that is exempt pursuant to the small project exemption specified in Labor Code Sections 1725.5 and 1771.1.

3.7.14 Labor Compliance; Stop Orders. If the Total Contract Price exceeds \$25,000, Contractor acknowledges that it is aware that this Project is subject to compliance monitoring and enforcement by the Department of Industrial Relations. It shall be the Contractor's sole responsibility to evaluate and pay the cost of complying with all labor compliance requirements under this Contract and applicable law. Any stop orders issued by the Department of Industrial Relations against Contractor or any subcontractor that affect Contractor's performance of Work, including any delay, shall be Contractor's sole responsibility. Any delay arising out of or resulting from such stop orders shall be considered Contractor caused delay subject to any applicable liquidated damages and shall not be compensable by the City. Contractor shall defend, indemnify and hold the City, its officials, officers, employees and agents free and harmless from any claim or liability arising out of stop orders issued by the Department of Industrial Relations against Contractor or any subcontractor.

3.8 Performance of Work; Jobsite Obligations.

3.8.1 Water Quality Management and Compliance.

3.8.1.1 Water Quality Management and Compliance. Contractor shall keep itself and all subcontractors, staff, and employees fully informed of and in compliance with all local, state and federal laws, rules and regulations that may impact, or be implicated by the performance of the Work including, without limitation, all applicable provisions of the Federal Water Pollution Control Act (33 U.S.C. §§ 1300); the California Porter-Cologne Water Quality Control Act (Cal Water Code §§ 13000-14950); local ordinances regulating discharges of storm water; and any and all regulations, policies, or permits issued pursuant to any such authority regulating the discharge of pollutants, as that term is used in the Porter-Cologne Water Quality Control Act, to any ground or surface water in the State.

3.8.1.2 Compliance with the Statewide Construction General Permit. Contractor shall comply with all conditions of the most recent iteration of the National Pollutant Discharge Elimination System General Permit for Storm Water Discharges Associated with Construction Activity, issued by the California State Water Resources Control Board ("Permit"). It shall be Contractor's sole responsibility to file a Notice of Intent and procure coverage under the Permit for all construction activity which results in the disturbance of more than one acre of total land area or which is part of a larger common area of development or sale. Prior to initiating work, Contractor shall be solely responsible for preparing and implementing a Storm Water Pollution Prevention Plan (SWPPP) as required by the Permit. Contractor shall be responsible for procuring, implementing and complying with the provisions of the Permit and the SWPPP, including the standard provisions, and monitoring and reporting requirements as required by the Permit. The Permit requires the SWPPP to be a "living document" that changes as necessary to meet the conditions and requirements of the job site as it progresses through different phases of construction and is subject to different weather conditions. It shall be Contractor's sole responsibility to update the SWPPP as necessary to address conditions at the project site.

3.8.1.3 Other Water Quality Rules Regulations and Policies. Contractor shall comply with the lawful requirements of any applicable municipality, drainage City, or local agency regarding discharges of storm water to separate storm drain systems or

other watercourses under their jurisdiction, including applicable requirements in municipal storm water management programs.

3.8.1.4 **Cost of Compliance.** Storm, surface, nuisance, or other waters may be encountered at various times during construction of The Work. Therefore, the Contractor, by submitting a Bid, hereby acknowledges that it has investigated the risk arising from such waters, has prepared its Bid accordingly, and assumes any and all risks and liabilities arising therefrom.

3.8.1.5 **Liability for Non-Compliance.** Failure to comply with the Permit is a violation of federal and state law. Pursuant to the indemnification provisions of this Contract, Contractor hereby agrees to defend, indemnify and hold harmless the City and its officials, officers, employees, volunteers and agents for any alleged violations. In addition, City may seek damages from Contractor for any delay in completing the Work in accordance with the Contract, if such delay is caused by or related to Contractor's failure to comply with the Permit.

3.8.1.6 **Reservation of Right to Defend.** City reserves the right to defend any enforcement action brought against the City for Contractor's failure to comply with the Permit or any other relevant water quality law, regulation, or policy. Pursuant to the indemnification provisions of this Contract, Contractor hereby agrees to be bound by, and to reimburse the City for the costs (including the City's attorney's fees) associated with, any settlement reached between the City and the relevant enforcement entity.

3.8.1.7 **Training.** In addition to the standard of performance requirements set forth in paragraph 3.4, Contractor warrants that all employees and subcontractors shall have sufficient skill and experience to perform the Work assigned to them without impacting water quality in violation of the laws, regulations and policies described in paragraph 3.8.1. Contractor further warrants that it, its employees and subcontractors will receive adequate training, as determined by City, regarding the requirements of the laws, regulations and policies described in paragraph 3.8.1 as they may relate to the Work provided under this Agreement. Upon request, City will provide the Contractor with a list of training programs that meet the requirements of this paragraph.

3.8.2 **Safety.** Contractor shall execute and maintain its work so as to avoid injury or damage to any person or property. Contractor shall comply with the requirements of the specifications relating to safety measures applicable in particular operations or kinds of work. In carrying out its Work, Contractor shall at all times be in compliance with all applicable local, state and federal laws, rules and regulations, and shall exercise all necessary precautions for the safety of employees appropriate to the nature of the Work and the conditions under which the Work is to be performed. Safety precautions as applicable shall include, but shall not be limited to, adequate life protection and lifesaving equipment; adequate illumination for underground and night operations; instructions in accident prevention for all employees, such as machinery guards, safe walkways, scaffolds, ladders, bridges, gang planks, confined space procedures, trenching and shoring, fall protection and other safety devices, equipment and wearing apparel as are necessary or lawfully required to prevent accidents or injuries; and adequate facilities for the proper inspection and maintenance of all safety measures. Furthermore, Contractor shall prominently display the names and telephone numbers of at least two medical doctors practicing in the vicinity of the Project, as well as the telephone number of the local ambulance service, adjacent to all telephones at the Project site.

3.8.3 **Laws and Regulations.** Contractor shall keep itself fully informed of and in compliance with all local, state and federal laws, rules and regulations in any manner

affecting the performance of the Contract or the Work, including all Cal/OSHA requirements, and shall give all notices required by law. Contractor shall be liable for all violations of such laws and regulations in connection with Work. If Contractor observes that the drawings or specifications are at variance with any law, rule or regulation, it shall promptly notify the City in writing. Any necessary changes shall be made by written change order. If Contractor performs any work knowing it to be contrary to such laws, rules and regulations and without giving written notice to the City, Contractor shall be solely responsible for all costs arising therefrom. City is a public entity of the State of California subject to certain provisions of the Health & Safety Code, Government Code, Public Contract Code, and Labor Code of the State. It is stipulated and agreed that all provisions of the law applicable to the public contracts of a municipality are a part of this Contract to the same extent as though set forth herein and will be complied with. Contractor shall defend, indemnify and hold City, its officials, officers, employees and agents free and harmless, pursuant to the indemnification provisions of this Contract, from any claim or liability arising out of any failure or alleged failure to comply with such laws, rules or regulations.

3.8.4 Permits and Licenses. Contractor shall be responsible for securing City permits and licenses necessary to perform the Work described herein, including, but not limited to, any required business license. While Contractor will not be charged a fee for any City permits, Contractor shall pay the City's business license fee, if any. Any ineligible contractor or subcontractor pursuant to Labor Code Sections 1777.1 and 1777.7 may not perform work on this Project.

3.8.5 Trenching Work. If the Total Contract Price exceeds \$25,000 and if the Work governed by this Contract entails excavation of any trench or trenches five (5) feet or more in depth, Contractor shall comply with all applicable provisions of the California Labor Code, including Section 6705. To this end, Contractor shall submit for City's review and approval a detailed plan showing the design of shoring, bracing, sloping, or other provisions to be made for worker protection from the hazard of caving ground during the excavation of such trench or trenches. If such plan varies from the shoring system standards, the plan shall be prepared by a registered civil or structural engineer.

3.8.6 Hazardous Materials and Differing Conditions. As required by California Public Contract Code Section 7104, if this Contract involves digging trenches or other excavations that extend deeper than four (4) feet below the surface, Contractor shall promptly, and prior to disturbance of any conditions, notify City of: (1) any material discovered in excavation that Contractor believes to be a hazardous waste that is required to be removed to a Class I, Class II or Class III disposal site; (2) subsurface or latent physical conditions at the site differing from those indicated by City; and (3) unknown physical conditions of an unusual nature at the site, significantly different from those ordinarily encountered in such contract work. Upon notification, City shall promptly investigate the conditions to determine whether a change order is appropriate. In the event of a dispute, Contractor shall not be excused from any scheduled completion date and shall proceed with all Work to be performed under the Contract, but shall retain all rights provided by the Contract or by law for making protests and resolving the dispute.

3.8.7 Underground Utility Facilities. To the extent required by Section 4215 of the California Government Code, City shall compensate Contractor for the costs of: (1) locating and repairing damage to underground utility facilities not caused by the failure of Contractor to exercise reasonable care; (2) removing or relocating underground utility facilities not indicated in the construction drawings; and (3) equipment necessarily idled during such work. Contractor shall not be assessed liquidated damages for delay caused by failure of City to provide for removal or relocation of such utility facilities.

3.8.8 Air Quality. Contractor must fully comply with all applicable laws, rules and regulations in furnishing or using equipment and/or providing services, including, but not limited to, emissions limits and permitting requirements imposed by the California Air Resources Board (CARB). Although CARB limits and requirements are more broad, Contractor shall specifically be aware of their application to "portable equipment", which definition is considered by CARB to include any item of equipment with a fuel-powered engine. Contractor shall indemnify City against any fines or penalties imposed by CARB, or any other governmental or regulatory agency for violations of applicable laws, rules and/or regulations by Contractor, its subcontractors, or others for whom Contractor is responsible under its indemnity obligations provided for in this Agreement.

3.8.9 State Recycling Mandates. Contractor shall comply with State Recycling Mandates. Any recyclable materials/debris collected by the contractor that can be feasibly diverted via reuse or recycling must be hauled by the appropriate handler for reuse or recycling.

3.9 Completion of Work. When Contractor determines that it has completed the Work required herein, Contractor shall so notify City in writing and shall furnish all labor and material releases required by this Contract. City shall thereupon inspect the Work. If the Work is not acceptable to the City, the City shall indicate to Contractor in writing the specific portions or items of Work which are unsatisfactory or incomplete. Once Contractor determines that it has completed the incomplete or unsatisfactory Work, Contractor may request a reinspection by the City. Once the Work is acceptable to City, City shall pay to Contractor the Total Contract Price remaining to be paid, less any amount which City may be authorized or directed by law to retain. Payment of retention proceeds due to Contractor shall be made in accordance with Section 7107 of the California Public Contract Code.

3.10 Claims; Government Code Claim Compliance.

3.10.1 Intent. Effective January 1, 1991, Section 20104 et seq., of the California Public Contract Code prescribes a process utilizing informal conferences, non-binding judicial supervised mediation, and judicial arbitration to resolve disputes on construction claims of \$375,000 or less. Effective January 1, 2017, Section 9204 of the Public Contract Code prescribes a process for negotiation and mediation to resolve disputes on construction claims. The intent of this Section is to implement Sections 20104 et seq. and Section 9204 of the California Public Contract Code. This Section shall be construed to be consistent with said statutes.

3.10.2 Claims. For purposes of this Section, "Claim" means a separate demand by the Contractor, after a change order duly requested in accordance with the terms of this Contract has been denied by the City, for (A) a time extension, (B) payment of money or damages arising from Work done by or on behalf of the Contractor pursuant to the Contract, or (C) an amount the payment of which is disputed by the City. Claims governed by this Section may not be filed unless and until the Contractor completes all procedures for giving notice of delay or change and for the requesting of a time extension or change order, including but not necessarily limited to the change order procedures contained herein, and Contractor's request for a change has been denied in whole or in part. Claims governed by this Section must be filed no later than fourteen (14) days after a request for change has been denied in whole or in part or after any other event giving rise to the Claim. The Claim shall be submitted in writing to the City and shall include on its first page the following in 16 point capital font: "THIS IS A CLAIM." Furthermore, the claim shall include the documents necessary to substantiate the claim. Nothing in this Section is intended to extend the time limit or supersede notice requirements

otherwise provided by contract for the filing of claims, including all requirements pertaining to compensation or payment for extra Work, disputed Work, and/or changed conditions. Failure to follow such contractual requirements shall bar any claims or subsequent lawsuits for compensation or payment thereon.

3.10.3 Supporting Documentation. The Contractor shall submit all claims in the following format:

3.10.3.1 Summary of claim merit and price, reference Contract Document provisions pursuant to which the claim is made

3.10.3.2 List of documents relating to claim:

- (A) Specifications
- (B) Drawings
- (C) Clarifications (Requests for Information)
- (D) Schedules
- (E) Other

3.10.3.3 Chronology of events and correspondence

3.10.3.4 Analysis of claim merit

3.10.3.5 Analysis of claim cost

3.10.3.6 Time impact analysis in CPM format

3.10.3.7 If Contractor's claim is based in whole or in part on an allegation of errors or omissions in the Drawings or Specifications for the Project, Contractor shall provide a summary of the percentage of the claim subject to design errors or omissions and shall obtain a certificate of merit in support of the claim of design errors and omissions.

3.10.3.8 Cover letter and certification of validity of the claim, including any claims from subcontractors of any tier, in accordance with Government Code section 12650 *et seq.*

3.10.4 City's Response. Upon receipt of a claim pursuant to this Section, City shall conduct a reasonable review of the claim and, within a period not to exceed 45 days, shall provide the Contractor a written statement identifying what portion of the claim is disputed and what portion is undisputed. Any payment due on an undisputed portion of the claim will be processed and made within 60 days after the public entity issues its written statement.

3.10.4.1 If City needs approval from its governing body to provide the Contractor a written statement identifying the disputed portion and the undisputed portion of the claim, and the governing body does not meet within the 45 days or within the mutually agreed to extension of time following receipt of a claim sent by registered mail or certified mail, return receipt requested, City shall have up to three days following the next duly publicly noticed meeting of the governing body after the 45-day period, or extension, expires to provide the Contractor a written statement identifying the disputed portion and the undisputed portion.

3.10.4.2 Within 30 days of receipt of a claim, City may request in writing additional documentation supporting the claim or relating to defenses or claims City may have against the Contractor. If additional information is thereafter required, it shall be requested and provided pursuant to this subdivision, upon mutual agreement of City and the Contractor.

3.10.4.3 City's written response to the claim, as further documented, shall be submitted to the Contractor within 30 days (if the claim is less than \$50,000, within 15 days) after receipt of the further documentation, or within a period of time no greater than that taken by the Contractor in producing the additional information or requested documentation, whichever is greater.

3.10.5 Meet and Confer. If the Contractor disputes City's written response, or City fails to respond within the time prescribed, the Contractor may so notify City, in writing, either within 15 days of receipt of City's response or within 15 days of City's failure to respond within the time prescribed, respectively, and demand an informal conference to meet and confer for settlement of the issues in dispute. Upon receipt of a demand, City shall schedule a meet and confer conference within 30 days for settlement of the dispute.

3.10.6 Mediation. Within 10 business days following the conclusion of the meet and confer conference, if the claim or any portion of the claim remains in dispute, City shall provide the Contractor a written statement identifying the portion of the claim that remains in dispute and the portion that is undisputed. Any payment due on an undisputed portion of the claim shall be processed and made within 60 days after City issues its written statement. Any disputed portion of the claim, as identified by the Contractor in writing, shall be submitted to nonbinding mediation, with City and the Contractor sharing the associated costs equally. City and Contractor shall mutually agree to a mediator within 10 business days after the disputed portion of the claim has been identified in writing, unless the parties agree to select a mediator at a later time.

3.10.6.1 If the Parties cannot agree upon a mediator, each Party shall select a mediator and those mediators shall select a qualified neutral third party to mediate with regard to the disputed portion of the claim. Each Party shall bear the fees and costs charged by its respective mediator in connection with the selection of the neutral mediator.

3.10.6.2 For purposes of this section, mediation includes any nonbinding process, including, but not limited to, neutral evaluation or a dispute review board, in which an independent third party or board assists the Parties in dispute resolution through negotiation or by issuance of an evaluation. Any mediation utilized shall conform to the timeframes in this section.

3.10.6.3 Unless otherwise agreed to by City and the Contractor in writing, the mediation conducted pursuant to this section shall excuse any further obligation under Section 20104.4 to mediate after litigation has been commenced.

3.10.6.4 The mediation shall be held no earlier than the date the Contractor completes the Work or the date that the Contractor last performs Work, whichever is earlier. All unresolved claims shall be considered jointly in a single mediation, unless a new unrelated claim arises after mediation is completed.

3.10.7 Procedures After Mediation. If following the mediation, the claim or any portion remains in dispute, the Contractor must file a claim pursuant to Chapter 1 (commencing with Section 900) and Chapter 2 (commencing with Section 910) of Part 3 of Division 3.6 of Title 1 of the Government Code. For purposes of those provisions, the running of the period of time

within which a claim must be filed shall be tolled from the time the Contractor submits his or her written claim pursuant to subdivision (a) until the time the claim is denied, including any period of time utilized by the meet and confer conference or mediation.

3.10.8 Civil Actions. The following procedures are established for all civil actions filed to resolve claims subject to this Section:

3.10.8.1 Within 60 days, but no earlier than 30 days, following the filing or responsive pleadings, the court shall submit the matter to non-binding mediation unless waived by mutual stipulation of both parties or unless mediation was held prior to commencement of the action in accordance with Public Contract Code section 9204 and the terms of these procedures.. The mediation process shall provide for the selection within 15 days by both parties of a disinterested third person as mediator, shall be commenced within 30 days of the submittal, and shall be concluded within 15 days from the commencement of the mediation unless a time requirement is extended upon a good cause showing to the court.

3.10.8.2 If the matter remains in dispute, the case shall be submitted to judicial arbitration pursuant to Chapter 2.5 (commencing with Section 1141.10) of Title 3 of Part 3 of the Code of Civil Procedure, notwithstanding Section 1114.11 of that code. The Civil Discovery Act of 1986 (Article 3 (commencing with Section 2016) of Chapter 3 of Title 3 of Part 4 of the Code of Civil Procedure) shall apply to any proceeding brought under this subdivision consistent with the rules pertaining to judicial arbitration.

3.10.8.3 In addition to Chapter 2.5 (commencing with Section 1141.10) of Title 3 of Part 3 of the Code of Civil Procedure, (A) arbitrators shall, when possible, be experienced in construction law, and (B) any party appealing an arbitration award who does not obtain a more favorable judgment shall, in addition to payment of costs and fees under that chapter, also pay the attorney's fees on appeal of the other party.

3.10.9 Government Code Claims. In addition to any and all contract requirements pertaining to notices of and requests for compensation or payment for extra work, disputed work, claims and/or changed conditions, Contractor must comply with the claim procedures set forth in Government Code sections 900 et seq. prior to filing any lawsuit against the City. Such Government Code claims and any subsequent lawsuit based upon the Government Code claims shall be limited to those matters that remain unresolved after all procedures pertaining to extra work, disputed work, claims, and/or changed conditions have been followed by Contractor. If no such Government Code claim is submitted, or if any prerequisite contractual requirements are not otherwise satisfied as specified herein, Contractor shall be barred from bringing and maintaining a valid lawsuit against the City. A Government Code claim must be filed no earlier than the date the work is completed or the date the Contractor last performs work on the Project, whichever occurs first. A Government Code claim shall be inclusive of all unresolved claims unless a new unrelated claim arises after the Government Code claim is submitted.

3.10.10 Non-Waiver. City's failure to respond to a claim from the Contractor within the time periods described in this Section or to otherwise meet the time requirements of this Section shall result in the claim being deemed rejected in its entirety. City's failure to respond shall not waive City's rights to any subsequent procedures for the resolution of disputed claims.

3.11 Loss and Damage. Except as may otherwise be limited by law, Contractor shall be responsible for all loss and damage which may arise out of the nature of the Work agreed to herein, or from the action of the elements, or from any unforeseen difficulties which may arise or

be encountered in the prosecution of the Work until the same is fully completed and accepted by City. In the event of damage proximately caused by an Act of God, as defined by Section 7105 of the Public Contract Code, the City may terminate this Contract pursuant to Section 3.17.3; provided, however, that the City needs to provide Contractor with only one (1) day advanced written notice.

3.12 Indemnification.

3.12.1 Scope of Indemnity. To the fullest extent permitted by law, Contractor shall defend, indemnify and hold the City, its officials, employees, agents and authorized volunteers free and harmless from any and all claims, demands, causes of action, suits, actions, proceedings, costs, expenses, liability, judgments, awards, decrees, settlements, loss, damage or injury of any kind, in law or equity, to property or persons, including wrongful death, (collectively, "Claims") in any manner arising out of, pertaining to, or incident to any alleged acts, errors or omissions, or willful misconduct of Contractor, its officials, officers, employees, subcontractors, consultants or agents in connection with the performance of the Contractor's services, the Project or this Agreement, including without limitation the payment of all consequential damages, expert witness fees and attorneys' fees and other related costs and expenses. Notwithstanding the foregoing, to the extent required by Civil Code section 2782, Contractor's indemnity obligation shall not apply to liability for damages for death or bodily injury to persons, injury to property, or any other loss, damage or expense arising from the sole or active negligence or willful misconduct of the City or the City's agents, servants, or independent contractors who are directly responsible to the City, or for defects in design furnished by those persons.

3.12.2 Additional Indemnity Obligations. Contractor shall defend, with counsel of City's choosing and at Contractor's own cost, expense and risk, any and all Claims covered by this section that may be brought or instituted against City or its officials, employees, agents and authorized volunteers. In addition, Contractor shall pay and satisfy any judgment, award or decree that may be rendered against City or its officials, employees, agents and authorized volunteers as part of any such claim, suit, action or other proceeding. Contractor shall also reimburse City for the cost of any settlement paid by City or its officials, employees, agents and authorized volunteers as part of any such claim, suit, action or other proceeding. Such reimbursement shall include payment for City's attorney's fees and costs, including expert witness fees. Contractor shall reimburse City and its officials, employees, agents and authorized volunteers, for any and all legal expenses and costs incurred by each of them in connection therewith or in enforcing the indemnity herein provided. Contractor's obligation to indemnify shall not be restricted to insurance proceeds, if any, received by the City, its officials, employees, agents and authorized volunteers.

3.13 Insurance.

3.13.1 Time for Compliance. Contractor shall not commence Work under this Contract until it has provided evidence satisfactory to the City that it has secured all insurance required under this section. In addition, Contractor shall not allow any subcontractor to commence work on any subcontract until it has provided evidence satisfactory to the City that the subcontractor has secured all insurance required under this section. Failure to provide and maintain all required insurance shall be grounds for the City to terminate this Contract for cause.

3.13.2 Minimum Requirements. Contractor shall, at its expense, procure and maintain for the duration of the Contract insurance against claims for injuries to persons or damages to property which may arise from or in connection with the performance of the Work hereunder by Contractor, its agents, representatives, employees or subcontractors. Contractor

shall also require all of its subcontractors to procure and maintain the same insurance for the duration of the Contract. Such insurance shall meet at least the following minimum levels of coverage:

3.13.2.1 Minimum Scope of Insurance. Coverage shall be at least as broad as the latest version of the following: (1) *General Liability*: Insurance Services Office Commercial General Liability coverage (occurrence form CG 00 01) OR Insurance Services Office Owners and Contractors Protective Liability Coverage Form (CG 00 09 11 88) (coverage for operations of designated contractor); (2) *Automobile Liability*: Insurance Services Office Business Auto Coverage form number CA 00 01, code 1 (any auto); and (3) *Workers' Compensation and Employer's Liability*: Workers' Compensation insurance as required by the State of California and Employer's Liability Insurance. Policies shall not contain exclusions contrary to this Contract.

3.13.2.2 Minimum Limits of Insurance. Contractor shall maintain limits no less than: (1) *General Liability*: \$1,000,000 per occurrence and \$1,000,000 aggregate for bodily injury, personal injury and property damage; (2) *Automobile Liability*: \$1,000,000 per accident for bodily injury and property damage; and (3) *Workers' Compensation and Employer's Liability*: Workers' compensation limits as required by the Labor Code of the State of California. Employer's Liability limits of \$1,000,000 each accident, policy limit bodily injury or disease, and each employee bodily injury or disease. Defense costs shall be available in addition to the limits. Notwithstanding the minimum limits specified herein, any available coverage shall be provided to the parties required to be named as additional insureds pursuant to this Contract.

3.13.3 Insurance Endorsements. The insurance policies shall contain the following provisions, or Contractor shall provide endorsements (amendments) on forms supplied or approved by the City to add the following provisions to the insurance policies:

3.13.3.1 General Liability. (1) Such policy shall give the City, its officials, employees, agents and authorized volunteers additional insured status using ISO endorsements CG20 10 10 01 plus CG20 37 10 01, or endorsements providing the exact same coverage, with respect to the Work or operations performed by or on behalf of Contractor, including materials, parts or equipment furnished in connection with such work; (2) all policies shall waive or shall permit Contractor to waive all rights of subrogation which may be obtained by the Contractor or any insurer by virtue of payment of any loss or any coverage provided to any person named as an additional insured pursuant to this Contract, and Contractor agrees to waive all such rights of subrogation; and (3) the insurance coverage shall be primary insurance as respects the City, its officials, employees, agents and authorized volunteers, or if excess, shall stand in an unbroken chain of coverage excess of Contractor's scheduled underlying coverage. Any insurance or self-insurance maintained by the City, its officials, employees, agents and authorized volunteers shall be excess of Contractor's insurance and shall not be called upon to contribute with it.

3.13.3.2 Automobile Liability. (1) Such policy shall give the City, its officials, employees, agents and authorized volunteers additional insured status with respect to the ownership, operation, maintenance, use, loading or unloading of any auto owned, leased, hired or borrowed by Contractor or for which Contractor is responsible; (2) all policies shall waive or shall permit Contractor to waive all rights of subrogation which may be obtained by the Contractor or any insurer by virtue of payment of any loss or any coverage provided to any person named as an additional insured pursuant to this Contract, and Contractor agrees to waive all such rights of subrogation; and (3) the insurance coverage shall be primary insurance as respects the City, its officials, employees, agents and authorized volunteers, or if excess,

shall stand in an unbroken chain of coverage excess of Contractor's scheduled underlying coverage. Any insurance or self-insurance maintained by the City, its officials, employees, agents and authorized volunteers shall be excess of Contractor's insurance and shall not be called upon to contribute with it in any way.

3.13.3.3 Workers' Compensation and Employer's Liability Coverage. The insurer shall agree to waive all rights of subrogation against the City, its officials, employees, agents and authorized volunteers for losses paid under the terms of the insurance policy which arise from work performed by Contractor.

3.13.3.4 All Coverages. Each insurance policy required by this Contract shall be endorsed to state that: (1) coverage shall not be suspended, voided, reduced or canceled except after thirty (30) days prior written notice by certified mail, return receipt requested, has been given to the City; and (2) any failure to comply with reporting or other provisions of the policies, including breaches of warranties, shall not affect coverage provided to the City, its officials, employees, agents and authorized volunteers.

3.13.4 Separation of Insureds; No Special Limitations. All insurance required by this Section shall contain standard separation of insureds provisions. In addition, such insurance shall not contain any special limitations on the scope of protection afforded to the City, its officials, employees, agents and authorized volunteers.

3.13.5 Deductibles and Self-Insurance Retentions. Any deductibles or self-insured retentions must be declared to and approved by the City. Contractor shall guarantee that, at the option of the City, either: (1) the insurer shall reduce or eliminate such deductibles or self-insured retentions as respects the City, its officials, employees, agents and authorized volunteers; or (2) the Contractor shall procure a bond or other financial guarantee acceptable to the City guaranteeing payment of losses and related investigation costs, claims and administrative and defense expenses.

3.13.6 Acceptability of Insurers. Insurance is to be placed with insurers with a current A.M. Best's rating no less than A:VII, licensed to do business in California, and satisfactory to the City. Exception may be made for the State Compensation Insurance Fund when not specifically rated.

3.13.7 Verification of Coverage. Contractor shall furnish City with original certificates of insurance and endorsements effecting coverage required by this Contract on forms satisfactory to the City. The certificates and endorsements for each insurance policy shall be signed by a person authorized by that insurer to bind coverage on its behalf, and shall be on forms supplied or approved by the City. All certificates and endorsements must be received and approved by the City before work commences. The City reserves the right to require complete, certified copies of all required insurance policies, at any time.

3.13.8 Subcontractors. All subcontractors shall meet the requirements of this Section before commencing Work. Contractor shall furnish separate certificates and endorsements for each subcontractor. Subcontractor policies of General Liability insurance shall name the City, its officials, employees, agents and authorized volunteers as additional insureds using form ISO 20 38 04 13 or endorsements providing the exact same coverage. All coverages for subcontractors shall be subject to all of the requirements stated herein except as otherwise agreed to by the City in writing.

3.13.9 Reporting of Claims. Contractor shall report to the City, in addition to Contractor's insurer, any and all insurance claims submitted by Contractor in connection with the Work under this Contract.

3.14 Bond Requirements.

3.14.1 Payment Bond. If required by law or otherwise specifically requested by City in Exhibit "C" attached hereto and incorporated herein by reference, Contractor shall execute and provide to City concurrently with this Contract a Payment Bond in an amount required by the City and in a form provided or approved by the City. If such bond is required, no payment will be made to Contractor until the bond has been received and approved by the City.

3.14.2 Performance Bond. If specifically requested by City in Exhibit "C" attached hereto and incorporated herein by reference, Contractor shall execute and provide to City concurrently with this Contract a Performance Bond in an amount required by the City and in a form provided or approved by the City. If such bond is required, no payment will be made to Contractor until the bond has been received and approved by the City.

3.14.3 Bond Provisions. Should, in City's sole opinion, any bond become insufficient or any surety be found to be unsatisfactory, Contractor shall renew or replace the effected bond within (ten) 10 days of receiving notice from City. In the event the surety or Contractor intends to reduce or cancel any required bond, at least thirty (30) days prior written notice shall be given to the City, and Contractor shall post acceptable replacement bonds at least ten (10) days prior to expiration of the original bonds. No further payments shall be deemed due or will be made under this Contract until any replacement bonds required by this Section are accepted by the City. To the extent, if any, that the Total Contract Price is increased in accordance with the Contract, Contractor shall, upon request of the City, cause the amount of the bond to be increased accordingly and shall promptly deliver satisfactory evidence of such increase to the City. If Contractor fails to furnish any required bond, the City may terminate the Contract for cause.

3.14.4 Surety Qualifications. Only bonds executed by an admitted surety insurer, as defined in California Code of Civil Procedure Section 995.120, shall be accepted. If a California-admitted surety insurer issuing bonds does not meet these requirements, the insurer will be considered qualified if it is in conformance with Section 995.660 of the California Code of Civil Procedure, and proof of such is provided to the City.

3.15 Warranty. Contractor warrants all Work under the Contract (which for purposes of this Section shall be deemed to include unauthorized work which has not been removed and any non-conforming materials incorporated into the Work) to be of good quality and free from any defective or faulty material and workmanship. Contractor agrees that for a period of one year (or the period of time specified elsewhere in the Contract or in any guarantee or warranty provided by any manufacturer or supplier of equipment or materials incorporated into the Work, whichever is later) after the date of final acceptance, Contractor shall within ten (10) days after being notified in writing by the City of any defect in the Work or non-conformance of the Work to the Contract, commence and prosecute with due diligence all Work necessary to fulfill the terms of the warranty at its sole cost and expense. Contractor shall act sooner as requested by the City in response to an emergency. In addition, Contractor shall, at its sole cost and expense, repair and replace any portions of the Work (or work of other contractors) damaged by its defective Work or which becomes damaged in the course of repairing or replacing defective Work. For any Work so corrected, Contractor's obligation hereunder to correct defective Work shall be reinstated for an additional one year period, commencing with the date of acceptance of such corrected Work. Contractor shall perform such tests as the City may require to verify that

any corrective actions, including, without limitation, redesign, repairs, and replacements comply with the requirements of the Contract. All costs associated with such corrective actions and testing, including the removal, replacement, and reinstatement of equipment and materials necessary to gain access, shall be the sole responsibility of Contractor. All warranties and guarantees of subcontractors, suppliers and manufacturers with respect to any portion of the Work, whether express or implied, are deemed to be obtained by Contractor for the benefit of the City, regardless of whether or not such warranties and guarantees have been transferred or assigned to the City by separate agreement and Contractor agrees to enforce such warranties and guarantees, if necessary, on behalf of the City. In the event that Contractor fails to perform its obligations under this Section, or under any other warranty or guaranty under this Contract, to the reasonable satisfaction of the City, the City shall have the right to correct and replace any defective or non-conforming Work and any work damaged by such work or the replacement or correction thereof at Contractor's sole expense. Contractor shall be obligated to fully reimburse the City for any expenses incurred hereunder upon demand.

3.16 Employee/Labor Certifications.

3.16.1 Contractor's Labor Certification. By its signature hereunder, Contractor certifies that he is aware of the provisions of Section 3700 of the California Labor Code which require every employer to be insured against liability for Worker's Compensation or to undertake self-insurance in accordance with the provisions of that Code, and agrees to comply with such provisions before commencing the performance of the Work. A certification form for this purpose, which is attached to this Contract as Exhibit "D" and incorporated herein by reference, shall be executed simultaneously with this Contract.

3.16.2 Equal Opportunity Employment. Contractor represents that it is an equal opportunity employer and that it shall not discriminate against any employee or applicant for employment because of race, religion, color, national origin, ancestry, sex, age or other interests protected by the State or Federal Constitutions. Such non-discrimination shall include, but not be limited to, all activities related to initial employment, upgrading, demotion, transfer, recruitment or recruitment advertising, layoff or termination.

3.16.3 Verification of Employment Eligibility. By executing this Contract, Contractor verifies that it fully complies with all requirements and restrictions of state and federal law respecting the employment of undocumented aliens, including, but not limited to, the Immigration Reform and Control Act of 1986, as may be amended from time to time, and shall require all subcontractors and sub-subcontractors to comply with the same.

3.17 General Provisions.

3.17.1 City's Representative. The City hereby designates the General Manager, or his or her designee, to act as its representative for the performance of this Contract ("City's Representative"). City's Representative shall have the power to act on behalf of the City for all purposes under this Contract. Contractor shall not accept direction or orders from any person other than the City's Representative or his or her designee.

3.17.2 Contractor's Representative. Before starting the Work, Contractor shall submit in writing the name, qualifications and experience of its proposed representative who shall be subject to the review and approval of the City ("Contractor's Representative"). Following approval by the City, Contractor's Representative shall have full authority to represent and act on behalf of Contractor for all purposes under this Contract. Contractor's Representative shall supervise and direct the Work, using his best skill and attention, and shall be responsible for all construction means, methods, techniques, sequences and procedures and

for the satisfactory coordination of all portions of the Work under this Contract. Contractor's Representative shall devote full time to the Project and either he or his designee, who shall be acceptable to the City, shall be present at the Work site at all times that any Work is in progress and at any time that any employee or subcontractor of Contractor is present at the Work site. Arrangements for responsible supervision, acceptable to the City, shall be made for emergency Work which may be required. Should Contractor desire to change its Contractor's Representative, Contractor shall provide the information specified above and obtain the City's written approval.

3.17.3 Termination. This Contract may be terminated by City at any time, either with or without cause, by giving Contractor three (3) days advance written notice. In the event of termination by City for any reason other than the fault of Contractor, City shall pay Contractor for all Work performed up to that time as provided herein. In the event of breach of the Contract by Contractor, City may terminate the Contract immediately without notice, may reduce payment to Contractor in the amount necessary to offset City's resulting damages, and may pursue any other available recourse against Contractor. Contractor may not terminate this Contract except for cause. In the event this Contract is terminated in whole or in part as provided, City may procure, upon such terms and in such manner as it may determine appropriate, services similar to those terminated. Further, if this Contract is terminated as provided, City may require Contractor to provide all finished or unfinished documents, data, diagrams, drawings, materials or other matter prepared or built by Contractor in connection with its performance of this Contract.

3.17.4 Contract Interpretation. Should any question arise regarding the meaning or import of any of the provisions of this Contract or written or oral instructions from City, the matter shall be referred to City's Representative, whose decision shall be binding upon Contractor.

3.17.5 Anti-Trust Claims. This provision shall be operative if this Contract is applicable to California Public Contract Code Section 7103.5. In entering into this Contract to supply goods, services or materials, Contractor hereby offers and agrees to assign to the City all rights, title, and interest in and to all causes of action it may have under Section 4 of the Clayton Act (15 U.S.C. Section 15) or under the Cartwright Act (Chapter 2, commencing with Section 16700, of Part 2 of Division 7 of the Business and Professions Code) arising from purchases of goods, services, or materials pursuant to the Contract. This assignment shall be made and become effective at the time the City tender final payment to Contractor, without further acknowledgment by the Parties.

3.17.6 Notices. All notices hereunder and communications regarding interpretation of the terms of the Contract or changes thereto shall be provided by the mailing thereof by registered or certified mail, return receipt requested, postage prepaid and addressed as follows:

CONTRACTOR:

Express Energy Services, Inc.
10610 Humbolt Street
Los Alamitos, CA 90720
Attn: Jacob Williams

CITY:

City of Arcadia
240 West Huntington Drive

Arcadia, California 91066
Attn: Carlos Aguilar, General Services Superintendent

Any notice so given shall be considered received by the other Party three (3) days after deposit in the U.S. Mail as stated above and addressed to the Party at the above address. Actual notice shall be deemed adequate notice on the date actual notice occurred, regardless of the method of service.

3.17.7 Time of Essence. Time is of the essence in the performance of this Contract.

3.17.8 Assignment Forbidden. Contractor shall not, either voluntarily or by action of law, assign or transfer this Contract or any obligation, right, title or interest assumed by Contractor herein without the prior written consent of City. If Contractor attempts an assignment or transfer of this Contract or any obligation, right, title or interest herein, City may, at its option, terminate and revoke the Contract and shall thereupon be relieved from any and all obligations to Contractor or its assignee or transferee.

3.17.9 No Third Party Beneficiaries. There are no intended third party beneficiaries of any right or obligation assumed by the Parties.

3.17.10 Laws, Venue, and Attorneys' Fees. This Agreement shall be interpreted in accordance with the laws of the State of California. If any action is brought to interpret or enforce any term of this Agreement, the action shall be brought in a state or federal court situated in the County of Los Angeles, State of California.

3.17.11 Counterparts. This Contract may be executed in counterparts, each of which shall constitute an original.

3.17.12 Successors. The Parties do for themselves, their heirs, executors, administrators, successors, and assigns agree to the full performance of all of the provisions contained in this Contract.

3.17.13 [Reserved]

3.17.14 Solicitation. Contractor maintains and warrants that it has not employed nor retained any company or person, other than a bona fide employee working solely for Contractor, to solicit or secure this Contract. Further, Contractor warrants that it has not paid nor has it agreed to pay any company or person, other than a bona fide employee working solely for Contractor, any fee, commission, percentage, brokerage fee, gift or other consideration contingent upon or resulting from the award or making of this Contract. For breach or violation of this warranty, City shall have the right to terminate this Contract without liability.

3.17.15 Conflict of Interest. Contractor maintains and warrants that it has not employed nor retained any company or person, other than a bona fide employee working solely for Contractor, to solicit or secure this Agreement. Further, Contractor warrants that it has not paid nor has it agreed to pay any company or person, other than a bona fide employee working solely for Contractor, any fee, commission, percentage, brokerage fee, gift or other consideration contingent upon or resulting from the award or making of this Agreement. For breach or violation of this warranty, City shall have the right to rescind this Agreement without liability. For the term of this Contract, no official, officer or employee of City, during the term of his or her service with City, shall have any direct interest in this Contract, or obtain any present

or anticipated material benefit arising therefrom. In addition, Contractor agrees to file, or to cause its employees or subcontractors to file, a Statement of Economic Interest with the City's Filing Officer as required under state law in the performance of the Work.

3.17.16 Certification of License.

3.17.16.1 Contractor certifies that as of the date of execution of this Contract, Contractor has a current contractor's license of the classification indicated below under Contractor's signature.

3.17.16.2 Contractors are required by law to be licensed and regulated by the Contractors' State License Board which has jurisdiction to investigate complaints against contractors if a complaint regarding a patent act or omission is filed within four (4) years of the date of the alleged violation. A complaint regarding a latent act or omission pertaining to structural defects must be filed within ten (10) years of the date of the alleged violation. Any questions concerning a contractor may be referred to the Registrar, Contractors' State License Board, P.O. Box 26000, Sacramento, California 95826.

3.17.17 Authority to Enter Contract. Each Party warrants that the individuals who have signed this Contract have the legal power, right and authority to make this Contract and bind each respective Party.

3.17.18 Entire Contract; Modification. This Contract contains the entire agreement of the Parties with respect to the subject matter hereof, and supersedes all prior negotiations, understandings or agreements. This Contract may only be modified by a writing signed by both Parties.

3.17.19 Non-Waiver. None of the provisions of this Agreement shall be considered waived by either party, unless such waiver is specifically specified in writing.

3.17.20 City's Right to Employ Other Contractors. City reserves right to employ other contractors in connection with this Project or other projects.

[SIGNATURES ON NEXT PAGE]

**SIGNATURE PAGE FOR CONSTRUCTION CONTRACT
BETWEEN THE CITY OF ARCADIA
AND EXPRESS ENERGY SERVICES, INC.**

IN WITNESS WHEREOF, the Parties have entered into this Agreement as of the _____ day of _____, 2024.

CITY OF ARCADIA

EXPRESS ENERGY SERVICES, INC.

By: _____
Dominic Lazaretto
City Manager

By: _____
Its: _____

Printed Name: _____

ATTEST:

By: _____

By: _____
City Clerk

Its: _____

Printed Name: _____

APPROVED AS TO FORM:

By: _____
Michael J. Maurer
City Attorney

EXHIBIT "A"

SERVICES / SCHEDULE

The project plan and proposal (Work Order Number 125850.00) are incorporated into this Contract. (see Attachment "A").

The project plan and proposal (EZIQC Contract No.: CA-R8-E-101723-Express) are incorporated into this Contract.

EXHIBIT "B"

PLANS AND SPECIFICATIONS

All service and unit specifications are listed in Exhibit "A".

EXHIBIT "C"

SPECIAL CONDITIONS

ARTICLE 1. BONDS

Within ten (10) calendar days from the date the Contractor is notified of award of the Contract, the Contractor shall deliver to the City four identical counterparts of the Performance Bond and Payment Bond on the forms supplied by the City and included as Exhibit "F" to the Contract. Failure to do so may, in the sole discretion of City, result in the forfeiture of Contractor's bid security. The surety supplying the bond must be an admitted surety insurer, as defined in Code of Civil Procedure Section 995.120, authorized to do business as such in the State of California and satisfactory to the City. The Performance Bond and the Payment Bond shall be for one hundred percent (100%) of the Total Contract Price.

EXHIBIT "D"

**CERTIFICATION
LABOR CODE - SECTION 1861**

I, the undersigned Contractor, am aware of the provisions of Section 3700, et seq., of the California Labor Code which require every employer to be insured against liability for Worker's Compensation or to undertake self-insurance in accordance with the provisions of the Code, and I, the undersigned Contractor, agree to and will comply with such provisions before commencing the performance of the Work on this Contract.

EXPRESS ENERGY SERVICES, INC.

By: _____
Signature

Name (Print)

Title (Print)

EXHIBIT "E"

PUBLIC WORKS CONTRACTOR REGISTRATION CERTIFICATION

Pursuant to Labor Code sections 1725.5 and 1771.1, all contractors and subcontractors that wish to bid on, be listed in a bid proposal, or enter into a contract to perform public work must be registered with the Department of Industrial Relations. See <http://www.dir.ca.gov/Public-Works/PublicWorks.html> for additional information.

No bid will be accepted nor any contract entered into without proof of the contractor's and subcontractors' current registration with the Department of Industrial Relations to perform public work.

Contractor hereby certifies that it is aware of the registration requirements set forth in Labor Code sections 1725.5 and 1771.1 and is currently registered as a contractor with the Department of Industrial Relations.¹

Name of Contractor: _____

DIR Registration Number: _____

DIR Registration Expiration: _____

Small Project Exemption: _____ Yes or _____ No

Unless Contractor is exempt pursuant to the small project exemption, Contractor further acknowledges:

- Contractor shall maintain a current DIR registration for the duration of the project.
- Contractor shall include the requirements of Labor Code sections 1725.5 and 1771.1 in its contract with subcontractors and ensure that all subcontractors are registered at the time of bid opening and maintain registration status for the duration of the project.
- Failure to submit this form or comply with any of the above requirements may result in a finding that the bid is non-responsive.

Name of Contractor _____

Signature _____

Name and Title _____

Dated _____

¹ If the Project is exempt from the contractor registration requirements pursuant to the small project exemption under Labor Code Sections 1725.5 and 1771.1, please mark "Yes" in response to "Small Project Exemption."

EXHIBIT "F"
PAYMENT AND PERFORMANCE BONDS

PERFORMANCE BOND

KNOW ALL PERSONS BY THESE PRESENTS:

THAT WHEREAS, the City of Arcadia (hereinafter referred to as "City") has awarded to **Express Energy Services, Inc.**, (hereinafter referred to as the "Contractor") an agreement for **Repair Underground Field Lighting Short at Dana Middle School Athletic Field project** (hereinafter referred to as the "Project").

WHEREAS, the work to be performed by the Contractor is more particularly set forth in the Contract Documents for the Project dated _____, (hereinafter referred to as "Contract Documents"), the terms and conditions of which are expressly incorporated herein by reference; and

WHEREAS, the Contractor is required by said Contract Documents to perform the terms thereof and to furnish a bond for the faithful performance of said Contract Documents.

NOW, THEREFORE, we, _____, the undersigned Contractor and _____ as Surety, a corporation organized and duly authorized to transact business under the laws of the State of California, are held and firmly bound unto the City in the sum of **THIRTY-EIGHT THOUSAND, EIGHT HUNDRED SEVENTY-TWO DOLLARS AND SEVENTY-SIX CENTS (\$38,872.76)**, said sum being not less than one hundred percent (100%) of the total amount of the Contract, for which amount well and truly to be made, we bind ourselves, our heirs, executors and administrators, successors and assigns, jointly and severally, firmly by these presents.

THE CONDITION OF THIS OBLIGATION IS SUCH, that, if the Contractor, his or its heirs, executors, administrators, successors or assigns, shall in all things stand to and abide by, and well and truly keep and perform the covenants, conditions and agreements in the Contract Documents and any alteration thereof made as therein provided, on its part, to be kept and performed at the time and in the manner therein specified, and in all respects according to their intent and meaning; and shall faithfully fulfill all obligations including the one-year guarantee of all materials and workmanship; and shall indemnify and save harmless the City, its officers and agents, as stipulated in said Contract Documents, then this obligation shall become null and void; otherwise it shall be and remain in full force and effect.

As a condition precedent to the satisfactory completion of the Contract Documents, unless otherwise provided for in the Contract Documents, the above obligation shall hold good for a period of one (1) year after the acceptance of the work by City, during which time if Contractor shall fail to make full, complete, and satisfactory repair and replacements and totally protect the City from loss or damage resulting from or caused by defective materials or faulty workmanship, Surety shall undertake and faithfully fulfill all such obligations. The obligations of Surety hereunder shall continue so long as any obligation of Contractor remains. Nothing herein shall limit the City's rights or the Contractor or Surety's obligations under the Contract, law or equity, including, but not limited to, California Code of Civil Procedure section 337.15.

Whenever Contractor shall be, and is declared by the City to be, in default under the Contract Documents, the Surety shall remedy the default pursuant to the Contract Documents, or shall promptly, at the City's option:

- (1) Take over and complete the Project in accordance with all terms and conditions in the Contract Documents; or
- (2) Obtain a bid or bids for completing the Project in accordance with all terms and conditions in the Contract Documents and upon determination by Surety of the lowest responsive and responsible bidder, arrange for a Contract between such bidder, the Surety and the City, and make available as work progresses sufficient funds to pay the cost of completion of the Project, less the balance of the contract price, including other costs and damages for which Surety may be liable. The term "balance of the contract price" as used in this paragraph shall mean the total amount payable to Contractor by the City under the Contract and any modification thereto, less any amount previously paid by the City to the Contractor and any other set offs pursuant to the Contract Documents.
- (3) Permit the City to complete the Project in any manner consistent with local, California and federal law and make available as work progresses sufficient funds to pay the cost of completion of the Project, less the balance of the contract price, including other costs and damages for which Surety may be liable. The term "balance of the contract price" as used in this paragraph shall mean the total amount payable to Contractor by the City under the Contract and any modification thereto, less any amount previously paid by the City to the Contractor and any other set offs pursuant to the Contract Documents.

Surety expressly agrees that the City may reject any contractor or subcontractor which may be proposed by Surety in fulfillment of its obligations in the event of default by the Contractor.

Surety shall not utilize Contractor in completing the Project nor shall Surety accept a bid from Contractor for completion of the Project if the City, when declaring the Contractor in default, notifies Surety of the City's objection to Contractor's further participation in the completion of the Project.

The Surety, for value received, hereby stipulates and agrees that no change, extension of time, alteration or addition to the terms of the Contract Documents or to the Project to be performed thereunder shall in any way affect its obligations on this bond, and it does hereby waive notice of any such change, extension of time, alteration or addition to the terms of the Contract Documents or to the Project, including but not limited to the provisions of sections 2819 and 2845 of the California Civil Code.

IN WITNESS WHEREOF, we have hereunto set our hands and seals this _____ day of _____, 20__).

(Corporate Seal)

Contractor/ Principal

By _____

Title _____

(Corporate Seal)

Surety

By _____
Attorney-in-Fact

Signatures of those signing for the Contractor and Surety must be notarized and evidence of corporate authority attached.

(Attach Attorney-in-Fact Certificate) Title _____

The rate of premium on this bond is _____ per thousand. The total amount of premium charges, \$_____.
(The above must be filled in by corporate attorney.)

THIS IS A REQUIRED FORM

Any claims under this bond may be addressed to:

(Name and Address of Surety) _____

(Name and Address of Agent or Representative for service of process in California, if different from above) _____

(Telephone number of Surety and Agent or Representative for service of process in California) _____

NOTE: A copy of the Power-of-Attorney authorizing the person signing on behalf of the Surety to do so must be attached hereto.

Notary Acknowledgment

A notary public or other officer completing this certificate verifies only the identity of the individual who signed the document to which this certificate is attached, and not the truthfulness, accuracy, or validity of that document.

STATE OF CALIFORNIA
 COUNTY OF _____

On _____, 20____, before me, _____, Notary Public, personally appeared _____, who proved to me on the basis of satisfactory

evidence to be the person(s) whose name(s) is/are subscribed to the within instrument and acknowledged to me that he/she/they executed the same in his/her/their authorized capacity(ies), and that by his/her/their signature(s) on the instrument the person(s), or the entity upon behalf of which the person(s) acted, executed the instrument.

I certify under PENALTY OF PERJURY under the laws of the State of California that the foregoing paragraph is true and correct.

WITNESS my hand and official seal.

Signature of Notary Public _____

OPTIONAL

Though the information below is not required by law, it may prove valuable to persons relying on the document and could prevent fraudulent removal and reattachment of this form to another document.

CAPACITY CLAIMED BY SIGNER

- Individual
- Corporate Officer

_____ Title(s)

- Partner(s) Limited
- General

- Attorney-In-Fact
- Trustee(s)
- Guardian/Conservator
- Other:

Signer is representing:
 Name Of Person(s) Or Entity(ies)

DESCRIPTION OF ATTACHED DOCUMENT

_____ Title or Type of Document

_____ Number of Pages

_____ Date of Document

_____ Signer(s) Other Than Named Above

PAYMENT BOND

KNOW ALL MEN BY THESE PRESENTS That

WHEREAS, the City of Arcadia (hereinafter designated as the "City"), by action taken or a resolution passed **May 7, 2024** has awarded to **Express Energy Services, Inc.** hereinafter designated as the "Principal," a contract for the work described as follows:

Repair Underground Field Lighting Short at Dana Middle School Athletic Field Project (the "Project"); and

WHEREAS, the work to be performed by the Principal is more particularly set forth in the Contract Documents for the Project dated _____ ("Contract Documents"), the terms and conditions of which are expressly incorporated by reference; and

WHEREAS, said Principal is required to furnish a bond in connection with said contract; providing that if said Principal or any of its Subcontractors shall fail to pay for any materials, provisions, provender, equipment, or other supplies used in, upon, for or about the performance of the work contracted to be done, or for any work or labor done thereon of any kind, or for amounts due under the Unemployment Insurance Code or for any amounts required to be deducted, withheld, and paid over to the Employment Development Department from the wages of employees of said Principal and its Subcontractors with respect to such work or labor the Surety on this bond will pay for the same to the extent hereinafter set forth.

NOW THEREFORE, we, the Principal and _____ as Surety, are held and firmly bound unto the City in the penal sum of **THIRTY-EIGHT THOUSAND, EIGHT HUNDRED SEVENTY-TWO DOLLARS AND SEVENTY-SIX CENTS (\$38,872.76)** lawful money of the United States of America, for the payment of which sum well and truly to be made, we bind ourselves, our heirs, executors, administrators, successors and assigns, jointly and severally, firmly by these presents.

THE CONDITION OF THIS OBLIGATION IS SUCH that if said Principal, his or its subcontractors, heirs, executors, administrators, successors or assigns, shall fail to pay any of the persons named in Section 9100 of the Civil Code, fail to pay for any materials, provisions or other supplies, used in, upon, for or about the performance of the work contracted to be done, or for any work or labor thereon of any kind, or amounts due under the Unemployment Insurance Code with respect to work or labor performed under the contract, or for any amounts required to be deducted, withheld, and paid over to the Employment Development Department or Franchise Tax Board from the wages of employees of the contractor and his subcontractors pursuant to Section 18663 of the Revenue and Taxation Code, with respect to such work and labor the Surety or Sureties will pay for the same, in an amount not exceeding the sum herein above specified.

This bond shall inure to the benefit of any of the persons named in Section 9100 of the Civil Code so as to give a right of action to such persons or their assigns in any suit brought upon this bond.

It is further stipulated and agreed that the Surety on this bond shall not be exonerated or released from the obligation of this bond by any change, extension of time for performance, addition, alteration or modification in, to, or of any contract, plans, specifications, or agreement pertaining or relating to any scheme or work of improvement herein above described, or pertaining or relating to the furnishing of labor, materials, or equipment therefore, nor by any change or modification of any terms of payment or extension of the time for any payment

pertaining or relating to any scheme or work of improvement herein above described, nor by any rescission or attempted rescission of the contract, agreement or bond, nor by any conditions precedent or subsequent in the bond attempting to limit the right of recovery of claimants otherwise entitled to recover under any such contract or agreement or under the bond, nor by any fraud practiced by any person other than the claimant seeking to recover on the bond and that this bond be construed most strongly against the Surety and in favor of all persons for whose benefit such bond is given, and under no circumstances shall Surety be released from liability to those for whose benefit such bond has been given, by reason of any breach of contract between the owner or City and original contractor or on the part of any obligee named in such bond, but the sole conditions of recovery shall be that claimant is a person described in Section 9100 of the Civil Code, and has not been paid the full amount of his claim and that Surety does hereby waive notice of any such change, extension of time, addition, alteration or modification herein mentioned and the provisions of sections 2819 and 2845 of the California Civil Code.

IN WITNESS WHEREOF, we have hereunto set our hands and seals this _____ day of _____, 20__.

(Corporate Seal)

Contractor/ Principal

By _____

Title _____

(Corporate Seal)

Surety

By _____

Attorney-in-Fact

Title _____

Signatures of those signing for the Contractor and Surety must be notarized and evidence of corporate authority attached. A Power-of-Attorney authorizing the person signing on behalf of the Surety to do so must be attached hereto.

NOTE: A copy of the Power-of-Attorney authorizing the person signing on behalf of the Surety to do so must be attached hereto.

Notary Acknowledgment

A notary public or other officer completing this certificate verifies only the identity of the individual who signed the document to which this certificate is attached, and not the truthfulness, accuracy, or validity of that document.

STATE OF CALIFORNIA
 COUNTY OF _____

On _____, 20____, before me, _____, Notary Public, personally appeared _____, who proved to me on the basis of satisfactory

evidence to be the person(s) whose name(s) is/are subscribed to the within instrument and acknowledged to me that he/she/they executed the same in his/her/their authorized capacity(ies), and that by his/her/their signature(s) on the instrument the person(s), or the entity upon behalf of which the person(s) acted, executed the instrument.

I certify under PENALTY OF PERJURY under the laws of the State of California that the foregoing paragraph is true and correct.

WITNESS my hand and official seal.

Signature of Notary Public _____

OPTIONAL

Though the information below is not required by law, it may prove valuable to persons relying on the document and could prevent fraudulent removal and reattachment of this form to another document.

CAPACITY CLAIMED BY SIGNER

- Individual
- Corporate Officer

 Title(s)

- Partner(s) Limited
- General
- Attorney-In-Fact
- Trustee(s)
- Guardian/Conservator
- Other:

Signer is representing:
 Name Of Person(s) Or Entity(ies)

DESCRIPTION OF ATTACHED DOCUMENT

 Title or Type of Document

 Number of Pages

 Date of Document

 Signer(s) Other Than Named Above

EXHIBIT "G"
FEDERAL REQUIREMENTS

NOT APPLICABLE.



STAFF REPORT

Public Works Services Department

DATE: May 7, 2024

TO: Honorable Mayor and City Council

FROM: Paul Cranmer, Public Works Services Director
By: Carlos Aguilar, General Services Superintendent

SUBJECT: CONTRACT WITH CARRIER CORPORATION FOR THE LIBRARY HVAC UNIT REPLACEMENTS IN THE AMOUNT OF \$140,469
CEQA: Exempt
Recommendation: Approve

SUMMARY

The Public Works Services Department (“PWSD”) is responsible for the maintenance and repair of all City facilities, which includes the Heating, Ventilation, and Air Conditioning (“HVAC”) units. Five HVAC units at the Arcadia Library are over 15 years old, have reached the end of their useful life and need replacement. Utilizing Sourcewell, a national cooperative purchasing program, enables the City to streamline the process of procuring and installing new HVAC units at the best price possible. It is recommended that the City Council approve, authorize, and direct the City Manager to execute a contract with Carrier Corporation for the Library HVAC Unit Replacements in the amount of \$140,469.

BACKGROUND

The PWSD currently has a preventative HVAC replacement program, designed to replace HVAC units every 12 to 15 years to reduce the chances of failure. The benefits of replacing HVAC units on a planned schedule include savings in electrical usage and unscheduled replacement costs. In addition, if an HVAC unit becomes inoperable, it can take up to four weeks to receive replacement parts and even longer to go through the procurement process to replace a unit that is beyond repair.

DISCUSSION

The existing five rooftop HVAC units at the Arcadia Library are over 15 years old. The motor bearings and condenser fan motors have deteriorated due to age and frequent use. Over the years, the coils, compressor, motor, and many of the electronics in the units have worn out and require constant maintenance. Most of the existing units have deteriorated to a point where they are beyond repair. Over the years, PWSD staff have replaced contactors, relays, control boards, and filters for individual units. Unfortunately,

the overall integrity of these units is completely compromised due to the piecemeal part replacement over the years. This project consists of removing and properly disposing of the existing HVAC units and installing five new HVAC units and platforms. The new HVAC units will be energy efficient and will have compressors that meet Air Quality Management District (“AQMD”) Freon regulations. The five new HVAC units will consist of one 10-ton unit, one 8.5-ton unit, one 4-ton unit, one 3-ton unit, and one 2-ton unit. As part of this project, the existing exterior galvanized ducting will also be removed and properly disposed of. Installation of the new units will include watertight sealant, liners, and all associated electrical work.

Utilizing Sourcewell, a national cooperative purchasing program, enables the City to streamline the procurement process for these services at a lower cost than the traditional competitive bidding process. The California Government Code authorizes public agencies to participate in cooperative purchasing agreements such as those established by Sourcewell, while remaining within the City’s adopted rules and procedures for purchasing. Sourcewell awarded a contract to Carrier Corporation for a series of specialized HVAC related services, including those needed for the Library HVAC Unit Replacements. A copy of the agreement between Sourcewell and Carrier Corporation is attached. The bidding process and the contract have been reviewed by the PWSD and meet the City’s procurement requirements. The City has previously contracted with Carrier Corporation and has been satisfied with their service.

ENVIRONMENTAL ANALYSIS

This Project is considered a Class 1 exemption as defined in Section 15301(a) “Existing Facilities” projects of the California Environmental Quality Act (“CEQA”), which exempts projects consisting of alterations to existing facilities like interior partitions, plumbing, and electrical conveyances.

FISCAL IMPACT

The total cost for the Library HVAC Unit Replacements is \$140,469. Funds in the amount of \$160,000 have been budgeted in the Fiscal Year 2022-23 and Fiscal Year 2023-24 Capital Improvement Program for the Library HVAC Unit Replacements. Therefore, sufficient funds are available.

RECOMMENDATION

It is recommended that the City Council determine that this project is exempt under the California Environmental Quality Act (“CEQA”); and approve, authorize, and direct the City Manager to execute a contract with Carrier Corporation for the Library HVAC Unit Replacements in the amount of \$140,469.

Award Library HVAC Unit Replacements
May 7, 2024
Page 3 of 3

Approved:



Dominic Lazzaretto
City Manager

Attachments: Sourcewell Contract
Proposed Construction Contract

**Solicitation Number: RFP #070121****CONTRACT**

This Contract is between Sourcewell, 202 12th Street Northeast, P.O. Box 219, Staples, MN 56479 (Sourcewell) and Carrier Global Corporation, 5900-H Northwoods Bus Pkwy., Charlotte, NC 28269 (Supplier).

Sourcewell is a State of Minnesota local government unit and service cooperative created under the laws of the State of Minnesota (Minnesota Statutes Section 123A.21) that offers cooperative procurement solutions to government entities. Participation is open to eligible federal, state/province, and municipal governmental entities, higher education, K-12 education, nonprofit, tribal government, and other public entities located in the United States and Canada. Sourcewell issued a public solicitation for HVAC Systems and Related Services from which Supplier was awarded a contract.

Supplier desires to contract with Sourcewell to provide equipment, products, or services to Sourcewell and the entities that access Sourcewell's cooperative purchasing contracts (Participating Entities).

1. TERM OF CONTRACT

- A. **EFFECTIVE DATE.** This Contract is effective upon the date of the final signature below.
- B. **EXPIRATION DATE AND EXTENSION.** This Contract expires August 12, 2025, unless it is cancelled sooner pursuant to Article 22. This Contract may be extended one additional year upon the request of Sourcewell and written agreement by Supplier.
- C. **SURVIVAL OF TERMS.** Notwithstanding any expiration or termination of this Contract, all payment obligations incurred prior to expiration or termination will survive, as will the following: Articles 11 through 14 survive the expiration or cancellation of this Contract. All rights will cease upon expiration or termination of this Contract.

2. EQUIPMENT, PRODUCTS, OR SERVICES

- A. **EQUIPMENT, PRODUCTS, OR SERVICES.** Supplier will provide the Equipment, Products, or Services as stated in its Proposal submitted under the Solicitation Number listed above.

Supplier's Equipment, Products, or Services Proposal (Proposal) is attached and incorporated into this Contract.

All Equipment and Products provided under this Contract must be new and the current model. Supplier may offer close-out or refurbished Equipment or Products if they are clearly indicated in Supplier's product and pricing list. Unless agreed to by the Participating Entities in advance, Equipment or Products must be delivered as operational to the Participating Entity's site.

This Contract offers an indefinite quantity of sales, and while substantial volume is anticipated, sales and sales volume are not guaranteed.

B. **WARRANTY.** Supplier warrants that all Equipment, Products, and Services furnished are free from liens and encumbrances, and are free from defects in design, materials, and workmanship. In addition, Supplier warrants the Equipment, Products, and Services are suitable for and will perform in accordance with the ordinary use for which they are intended. Supplier's dealers and distributors must agree to assist the Participating Entity in reaching a resolution in any dispute over warranty terms with the manufacturer. Any manufacturer's warranty that extends beyond the expiration of the Supplier's warranty will be passed on to the Participating Entity.

C. **DEALERS, DISTRIBUTORS, AND/OR RESELLERS.** Upon Contract execution and throughout the Contract term, Supplier must provide to Sourcewell a current means to validate or authenticate Supplier's authorized dealers, distributors, or resellers relative to the Equipment, Products, and Services offered under this Contract, which will be incorporated into this Contract by reference. It is the Supplier's responsibility to ensure Sourcewell receives the most current information.

3. PRICING

All Equipment, Products, or Services under this Contract will be priced at or below the price stated in Supplier's Proposal.

When providing pricing quotes to Participating Entities, all pricing quoted must reflect a Participating Entity's total cost of acquisition. This means that the quoted cost is for delivered Equipment, Products, and Services that are operational for their intended purpose, and includes all costs to the Participating Entity's requested delivery location.

Regardless of the payment method chosen by the Participating Entity, the total cost associated with any purchase option of the Equipment, Products, or Services must always be disclosed in the pricing quote to the applicable Participating Entity at the time of purchase.

A. **SHIPPING AND SHIPPING COSTS.** All delivered Equipment and Products must be properly packaged. Damaged Equipment and Products may be rejected. If the damage is not readily apparent at the time of delivery, Supplier must permit the Equipment and Products to be

returned within a reasonable time at no cost to Sourcewell or its Participating Entities. Participating Entities reserve the right to inspect the Equipment and Products at a reasonable time after delivery where circumstances or conditions prevent effective inspection of the Equipment and Products at the time of delivery. In the event of the delivery of nonconforming Equipment and Products, the Participating Entity will notify the Supplier as soon as possible and the Supplier will replace nonconforming Equipment and Products with conforming Equipment and Products that are acceptable to the Participating Entity.

Supplier must arrange for and pay for the return shipment on Equipment and Products that arrive in a defective or inoperable condition.

Sourcewell may declare the Supplier in breach of this Contract if the Supplier intentionally delivers substandard or inferior Equipment or Products.

B. SALES TAX. Each Participating Entity is responsible for supplying the Supplier with valid tax-exemption certification(s). When ordering, a Participating Entity must indicate if it is a tax-exempt entity.

C. HOT LIST PRICING. At any time during this Contract, Supplier may offer a specific selection of Equipment, Products, or Services at discounts greater than those listed in the Contract. When Supplier determines it will offer Hot List Pricing, it must be submitted electronically to Sourcewell in a line-item format. Equipment, Products, or Services may be added or removed from the Hot List at any time through a Sourcewell Price and Product Change Form as defined in Article 4 below.

Hot List program and pricing may also be used to discount and liquidate close-out and discontinued Equipment and Products as long as those close-out and discontinued items are clearly identified as such. Current ordering process and administrative fees apply. Hot List Pricing must be published and made available to all Participating Entities.

4. PRODUCT AND PRICING CHANGE REQUESTS

Supplier may request Equipment, Product, or Service changes, additions, or deletions at any time. All requests must be made in writing by submitting a signed Sourcewell Price and Product Change Request Form to the assigned Sourcewell Supplier Development Administrator. This approved form is available from the assigned Sourcewell Supplier Development Administrator. At a minimum, the request must:

- Identify the applicable Sourcewell contract number;
- Clearly specify the requested change;
- Provide sufficient detail to justify the requested change;

- Individually list all Equipment, Products, or Services affected by the requested change, along with the requested change (e.g., addition, deletion, price change); and
- Include a complete restatement of pricing documentation in Microsoft Excel with the effective date of the modified pricing, or product addition or deletion. The new pricing restatement must include all Equipment, Products, and Services offered, even for those items where pricing remains unchanged.

A fully executed Sourcewell Price and Product Request Form will become an amendment to this Contract and will be incorporated by reference.

5. PARTICIPATION, CONTRACT ACCESS, AND PARTICIPATING ENTITY REQUIREMENTS

A. PARTICIPATION. Sourcewell's cooperative contracts are available and open to public and nonprofit entities across the United States and Canada; such as federal, state/province, municipal, K-12 and higher education, tribal government, and other public entities.

The benefits of this Contract should be available to all Participating Entities that can legally access the Equipment, Products, or Services under this Contract. A Participating Entity's authority to access this Contract is determined through its cooperative purchasing, interlocal, or joint powers laws. Any entity accessing benefits of this Contract will be considered a Service Member of Sourcewell during such time of access. Supplier understands that a Participating Entity's use of this Contract is at the Participating Entity's sole convenience and Participating Entities reserve the right to obtain like Equipment, Products, or Services from any other source.

Supplier is responsible for familiarizing its sales and service forces with Sourcewell contract use eligibility requirements and documentation and will encourage potential participating entities to join Sourcewell. Sourcewell reserves the right to add and remove Participating Entities to its roster during the term of this Contract.

B. PUBLIC FACILITIES. Supplier's employees may be required to perform work at government-owned facilities, including schools. Supplier's employees and agents must conduct themselves in a professional manner while on the premises, and in accordance with Participating Entity policies and procedures, and all applicable laws.

6. PARTICIPATING ENTITY USE AND PURCHASING

A. ORDERS AND PAYMENT. To access the contracted Equipment, Products, or Services under this Contract, a Participating Entity must clearly indicate to Supplier that it intends to access this Contract; however, order flow and procedure will be developed jointly between Sourcewell and Supplier. Typically, a Participating Entity will issue an order directly to Supplier or its authorized subsidiary, distributor, dealer, or reseller. If a Participating Entity issues a purchase order, it may use its own forms, but the purchase order should clearly note the applicable Sourcewell

contract number. All Participating Entity orders under this Contract must be issued prior to expiration or cancellation of this Contract; however, Supplier performance, Participating Entity payment obligations, and any applicable warranty periods or other Supplier or Participating Entity obligations may extend beyond the term of this Contract.

Supplier's acceptable forms of payment are included in its attached Proposal. Participating Entities will be solely responsible for payment and Sourcewell will have no liability for any unpaid invoice of any Participating Entity.

B. **ADDITIONAL TERMS AND CONDITIONS/PARTICIPATING ADDENDUM.** Additional terms and conditions to a purchase order, or other required transaction documentation, may be negotiated between a Participating Entity and Supplier, such as job or industry-specific requirements, legal requirements (e.g., affirmative action or immigration status requirements), or specific local policy requirements. Some Participating Entities may require the use of a Participating Addendum; the terms of which will be negotiated directly between the Participating Entity and the Supplier. Any negotiated additional terms and conditions must never be less favorable to the Participating Entity than what is contained in this Contract.

C. **SPECIALIZED SERVICE REQUIREMENTS.** In the event that the Participating Entity requires service or specialized performance requirements not addressed in this Contract (such as e-commerce specifications, specialized delivery requirements, or other specifications and requirements), the Participating Entity and the Supplier may enter into a separate, standalone agreement, apart from this Contract. Sourcewell, including its agents and employees, will not be made a party to a claim for breach of such agreement.

D. **TERMINATION OF ORDERS.** Participating Entities may terminate an order, in whole or in part, immediately upon notice to Supplier in the event of any of the following events:

1. The Participating Entity fails to receive funding or appropriation from its governing body at levels sufficient to pay for the equipment, products, or services to be purchased; or
2. Federal, state, or provincial laws or regulations prohibit the purchase or change the Participating Entity's requirements.

E. **GOVERNING LAW AND VENUE.** The governing law and venue for any action related to a Participating Entity's order will be determined by the Participating Entity making the purchase.

7. CUSTOMER SERVICE

A. **PRIMARY ACCOUNT REPRESENTATIVE.** Supplier will assign an Account Representative to Sourcewell for this Contract and must provide prompt notice to Sourcewell if that person is changed. The Account Representative will be responsible for:

- Maintenance and management of this Contract;
- Timely response to all Sourcwell and Participating Entity inquiries; and
- Business reviews to Sourcwell and Participating Entities, if applicable.

B. BUSINESS REVIEWS. Supplier must perform a minimum of one business review with Sourcwell per contract year. The business review will cover sales to Participating Entities, pricing and contract terms, administrative fees, sales data reports, supply issues, customer issues, and any other necessary information.

8. REPORT ON CONTRACT SALES ACTIVITY AND ADMINISTRATIVE FEE PAYMENT

A. CONTRACT SALES ACTIVITY REPORT. Each calendar quarter, Supplier must provide a contract sales activity report (Report) to the Sourcwell Supplier Development Administrator assigned to this Contract. Reports are due no later than 45 days after the end of each calendar quarter. A Report must be provided regardless of the number or amount of sales during that quarter (i.e., if there are no sales, Supplier must submit a report indicating no sales were made).

The Report must contain the following fields:

- Participating Entity Name (e.g., City of Staples Highway Department);
- Participating Entity Physical Street Address;
- Participating Entity City;
- Participating Entity State/Province;
- Participating Entity Zip/Postal Code;
- Participating Entity Contact Name;
- Participating Entity Contact Email Address;
- Participating Entity Contact Telephone Number;
- Sourcwell Assigned Entity/Participating Entity Number;
- Item Purchased Description;
- Item Purchased Price;
- Sourcwell Administrative Fee Applied; and
- Date Purchase was invoiced/sale was recognized as revenue by Supplier.

B. ADMINISTRATIVE FEE. In consideration for the support and services provided by Sourcwell, the Supplier will pay an administrative fee to Sourcwell on all Equipment, Products, and Services provided to Participating Entities. The Administrative Fee must be included in, and not added to, the pricing. Supplier may not charge Participating Entities more than the contracted price to offset the Administrative Fee.

The Supplier will submit payment to Sourcwell for the percentage of administrative fee stated in the Proposal multiplied by the total sales of all Equipment, Products, and Services purchased

by Participating Entities under this Contract during each calendar quarter. Payments should note the Supplier's name and Sourcewell-assigned contract number in the memo; and must be mailed to the address above "Attn: Accounts Receivable" or remitted electronically to Sourcewell's banking institution per Sourcewell's Finance department instructions. Payments must be received no later than 45 calendar days after the end of each calendar quarter.

Supplier agrees to cooperate with Sourcewell in auditing transactions under this Contract to ensure that the administrative fee is paid on all items purchased under this Contract.

In the event the Supplier is delinquent in any undisputed administrative fees, Sourcewell reserves the right to cancel this Contract and reject any proposal submitted by the Supplier in any subsequent solicitation. In the event this Contract is cancelled by either party prior to the Contract's expiration date, the administrative fee payment will be due no more than 30 days from the cancellation date.

9. AUTHORIZED REPRESENTATIVE

Sourcewell's Authorized Representative is its Chief Procurement Officer.

Supplier's Authorized Representative is the person named in the Supplier's Proposal. If Supplier's Authorized Representative changes at any time during this Contract, Supplier must promptly notify Sourcewell in writing.

10. AUDIT, ASSIGNMENT, AMENDMENTS, WAIVER, AND CONTRACT COMPLETE

A. **AUDIT.** Pursuant to Minnesota Statutes Section 16C.05, subdivision 5, the books, records, documents, and accounting procedures and practices relevant to this Agreement are subject to examination by Sourcewell or the Minnesota State Auditor for a minimum of six years from the end of this Contract. This clause extends to Participating Entities as it relates to business conducted by that Participating Entity under this Contract.

B. **ASSIGNMENT.** Neither party may assign or otherwise transfer its rights or obligations under this Contract without the prior written consent of the other party and a fully executed assignment agreement. Such consent will not be unreasonably withheld. Any prohibited assignment will be invalid.

C. **AMENDMENTS.** Any amendment to this Contract must be in writing and will not be effective until it has been duly executed by the parties.

D. **WAIVER.** Failure by either party to take action or assert any right under this Contract will not be deemed a waiver of such right in the event of the continuation or repetition of the circumstances giving rise to such right. Any such waiver must be in writing and signed by the parties.

E. **CONTRACT COMPLETE.** This Contract represents the complete agreement between the parties. No other understanding regarding this Contract, whether written or oral, may be used to bind either party. For any conflict between the attached Proposal and the terms set out in Articles 1-22 of this Contract, the terms of Articles 1-22 will govern.

F. **RELATIONSHIP OF THE PARTIES.** The relationship of the parties is one of independent contractors, each free to exercise judgment and discretion with regard to the conduct of their respective businesses. This Contract does not create a partnership, joint venture, or any other relationship such as master-servant, or principal-agent.

11. INDEMNITY AND HOLD HARMLESS

Supplier must indemnify, defend, save, and hold Sourcewell and its Participating Entities, including their agents and employees, harmless from any third-party claims or causes of action, including attorneys' fees incurred by Sourcewell or its Participating Entities, arising out of any act or omission in the performance of this Contract by the Supplier or its agents or employees; this indemnification includes injury or death to person(s) or property alleged to have been caused by some defect in the Equipment, Products, or Services under this Contract to the extent the Equipment, Product, or Service has been used according to its specifications. Sourcewell's responsibility will be governed by the State of Minnesota's Tort Liability Act (Minnesota Statutes Chapter 466) and other applicable law.

Under no circumstances will Supplier be liable for any incidental, special, liquidated or consequential damages, including loss of revenue, loss of use of equipment or facilities, or economic damages based on strict liability or negligence.

12. GOVERNMENT DATA PRACTICES

Supplier and Sourcewell must comply with the Minnesota Government Data Practices Act, Minnesota Statutes Chapter 13, as it applies to all data provided by or provided to Sourcewell under this Contract and as it applies to all data created, collected, received, stored, used, maintained, or disseminated by the Supplier under this Contract.

13. INTELLECTUAL PROPERTY, PUBLICITY, MARKETING, AND ENDORSEMENT

A. INTELLECTUAL PROPERTY

1. *Grant of License.* During the term of this Contract:
 - a. Sourcewell grants to Supplier a royalty-free, worldwide, non-exclusive right and license to use the trademark(s) provided to Supplier by Sourcewell in advertising and promotional materials for the purpose of marketing Sourcewell's relationship with Supplier.

b. Supplier grants to Sourcewell a royalty-free, worldwide, non-exclusive right and license to use Supplier's trademarks in advertising and promotional materials for the purpose of marketing Supplier's relationship with Sourcewell.

2. *Limited Right of Sublicense.* The right and license granted herein includes a limited right of each party to grant sublicenses to their respective subsidiaries, distributors, dealers, resellers, marketing representatives, and agents (collectively "Permitted Sublicensees") in advertising and promotional materials for the purpose of marketing the Parties' relationship to Participating Entities. Any sublicense granted will be subject to the terms and conditions of this Article. Each party will be responsible for any breach of this Article by any of their respective sublicensees.

3. *Use; Quality Control.*

a. Neither party may alter the other party's trademarks from the form provided and must comply with removal requests as to specific uses of its trademarks or logos.

b. Each party agrees to use, and to cause its Permitted Sublicensees to use, the other party's trademarks only in good faith and in a dignified manner consistent with such party's use of the trademarks. Upon written notice to the breaching party, the breaching party has 30 days of the date of the written notice to cure the breach or the license will be terminated.

4. As applicable, Supplier agrees to indemnify and hold harmless Sourcewell and its Participating Entities against any and all suits, claims, judgments, and costs instituted or recovered against Sourcewell or Participating Entities by any person on account of the use of any Equipment or Products by Sourcewell or its Participating Entities supplied by Supplier in violation of applicable patent or copyright laws.

5. *Termination.* Upon the termination of this Contract for any reason, each party, including Permitted Sublicensees, will have 30 days to remove all Trademarks from signage, websites, and the like bearing the other party's name or logo (excepting Sourcewell's pre-printed catalog of suppliers which may be used until the next printing). Supplier must return all marketing and promotional materials, including signage, provided by Sourcewell, or dispose of it according to Sourcewell's written directions.

B. **PUBLICITY.** Any publicity regarding the subject matter of this Contract must not be released without prior written approval from the Authorized Representatives. Publicity includes notices, informational pamphlets, press releases, research, reports, signs, and similar public notices prepared by or for the Supplier individually or jointly with others, or any subcontractors, with respect to the program, publications, or services provided resulting from this Contract.

C. **MARKETING.** Any direct advertising, marketing, or offers with Participating Entities must be approved by Sourcewell. Send all approval requests to the Sourcewell Supplier Development Administrator assigned to this Contract.

D. **ENDORSEMENT.** The Supplier must not claim that Sourcewell endorses its Equipment, Products, or Services.

14. GOVERNING LAW, JURISDICTION, AND VENUE

The substantive and procedural laws of the State of Minnesota will govern this Contract. Venue for all legal proceedings arising out of this Contract, or its breach, must be in the appropriate state court in Todd County, Minnesota or federal court in Fergus Falls, Minnesota.

15. FORCE MAJEURE

Neither party to this Contract will be held responsible for delay or default caused by acts of God or other conditions that are beyond that party's reasonable control. A party defaulting under this provision must provide the other party prompt written notice of the default.

16. SEVERABILITY

If any provision of this Contract is found by a court of competent jurisdiction to be illegal, unenforceable, or void then both parties will be relieved from all obligations arising from that provision. If the remainder of this Contract is capable of being performed, it will not be affected by such determination or finding and must be fully performed.

17. PERFORMANCE, DEFAULT, AND REMEDIES

A. **PERFORMANCE.** During the term of this Contract, the parties will monitor performance and address unresolved contract issues as follows:

1. *Notification.* The parties must promptly notify each other of any known dispute and work in good faith to resolve such dispute within a reasonable period of time. If necessary, Sourcewell and the Supplier will jointly develop a short briefing document that describes the issue(s), relevant impact, and positions of both parties.
2. *Escalation.* If parties are unable to resolve the issue in a timely manner, as specified above, either Sourcewell or Supplier may escalate the resolution of the issue to a higher level of management. The Supplier will have 30 calendar days to cure an outstanding issue.
3. *Performance while Dispute is Pending.* Notwithstanding the existence of a dispute, the Supplier must continue without delay to carry out all of its responsibilities under the Contract that are not affected by the dispute. If the Supplier fails to continue without delay to perform its responsibilities under the Contract, in the accomplishment of all undisputed work, the Supplier will bear any additional costs incurred by Sourcewell and/or its Participating Entities as a result of such failure to proceed.

B. **DEFAULT AND REMEDIES.** Either of the following constitutes cause to declare this Contract, or any Participating Entity order under this Contract, in default:

1. Nonperformance of contractual requirements, or

2. A material breach of any term or condition of this Contract.

The party claiming default must provide written notice of the default, with 30 calendar days to cure the default. Time allowed for cure will not diminish or eliminate any liability for liquidated or other damages. If the default remains after the opportunity for cure, the non-defaulting party may:

- Exercise any remedy provided by law or equity, or
- Terminate the Contract or any portion thereof, including any orders issued against the Contract.

18. INSURANCE

A. REQUIREMENTS. At its own expense, Supplier must maintain insurance policy(ies) in effect at all times during the performance of this Contract with insurance company(ies) authorized to do business in the State of Minnesota having an "AM BEST" rating of A- or better, with coverage and limits of insurance of the following:

1. *Workers' Compensation and Employer's Liability.*

Workers' Compensation: As required by any applicable law or regulation.

Employer's Liability Insurance: must be provided in amounts listed below:

Limits:

\$500,000 each accident for bodily injury by accident

\$500,000 policy limit for bodily injury by disease

\$500,000 each employee for bodily injury by disease

2. *Commercial General Liability Insurance.* Supplier will maintain insurance covering its operations, with coverage on an occurrence basis, and must be subject to terms no less broad than the Insurance Services Office ("ISO") Commercial General Liability Form CG0001 (2001 or newer edition), or equivalent. At a minimum, coverage must include liability arising from premises, operations, bodily injury and property damage, independent contractors, products-completed operations including construction defect, contractual liability, blanket contractual liability, and personal injury and advertising injury. All required limits, terms and conditions of coverage must be maintained during the term of this Contract.

Limits:

\$1,000,000 each occurrence Bodily Injury and Property Damage

\$1,000,000 Personal and Advertising Injury

\$2,000,000 aggregate for Products-Completed operations

\$2,000,000 general aggregate

3. *Commercial Automobile Liability Insurance.* During the term of this Contract, Supplier will maintain insurance covering all owned, hired, and non-owned automobiles

in limits of liability as indicated below. The coverage must be subject to terms no less broad than ISO Business Auto Coverage Form CA 0001 (2010 edition or newer), or equivalent.

Limits:

\$1,000,000 each accident, combined single limit

4. *Umbrella Insurance*. During the term of this Contract, Supplier will maintain umbrella coverage over Employer's Liability, Commercial General Liability, and Commercial Automobile.

Limits:

\$2,000,000 per occurrence and in aggregate

5. *Network Security and Privacy Liability Insurance*. During the term of this Contract, Supplier will maintain coverage for network security and privacy liability. The coverage may be endorsed on another form of liability coverage or written on a standalone policy. The insurance must cover claims which may arise from failure of Supplier's security resulting in, but not limited to, computer attacks, unauthorized access, disclosure of not public data – including but not limited to, confidential or private information, transmission of a computer virus, or denial of service.

Limits:

\$2,000,000 per claim

\$2,000,000 annual aggregate

Failure of Supplier to maintain the required insurance will constitute a material breach entitling Sourcewell to immediately terminate this Contract for default.

B. CERTIFICATES OF INSURANCE. Prior to commencing under this Contract, Supplier must furnish to Sourcewell a certificate of insurance, as evidence of the insurance required under this Contract. Prior to expiration of the policy(ies), renewal certificates must be mailed to Sourcewell, 202 12th Street Northeast, P.O. Box 219, Staples, MN 56479 or sent to the Sourcewell Supplier Development Administrator assigned to this Contract. The certificates must be signed by a person authorized by the insurer(s) to bind coverage on their behalf.

Failure to request certificates of insurance by Sourcewell, or failure of Supplier to provide certificates of insurance, in no way limits or relieves Supplier of its duties and responsibilities in this Contract.

C. ADDITIONAL INSURED ENDORSEMENT AND PRIMARY AND NON-CONTRIBUTORY INSURANCE CLAUSE. Supplier agrees to list Sourcewell and its Participating Entities, including their officers, agents, and employees, as an additional insured under the Supplier's commercial general liability insurance policy with respect to liability arising out of activities, "operations," or "work" performed by or on behalf of Supplier, and products and completed operations of Supplier. The policy provision(s) or endorsement(s) must further provide that coverage is

primary and not excess over or contributory with any other valid, applicable, and collectible insurance or self-insurance in force for the additional insureds.

D. **WAIVER OF SUBROGATION.** Supplier waives and must require (by endorsement or otherwise) all its insurers to waive subrogation rights against Sourcewell and other additional insureds for losses paid under the insurance policies required by this Contract or other insurance applicable to the Supplier or its subcontractors, except such rights as Supplier has to proceeds. The waiver must apply to all deductibles and/or self-insured retentions applicable to the required or any other insurance maintained by the Supplier or its subcontractors. Where permitted by law, Supplier must require similar written express waivers of subrogation and insurance clauses from each of its subcontractors.

E. **UMBRELLA/EXCESS LIABILITY/SELF-INSURED RETENTION.** The limits required by this Contract can be met by either providing a primary policy or in combination with umbrella/excess liability policy(ies), or self-insured retention.

19. COMPLIANCE

A. **LAWS AND REGULATIONS.** All Equipment, Products, or Services provided under this Contract must comply fully with applicable federal laws and regulations, and with the laws in the states and provinces in which the Equipment, Products, or Services are sold.

B. **LICENSES.** Supplier must maintain a valid and current status on all required federal, state/provincial, and local licenses, bonds, and permits required for the operation of the business that the Supplier conducts with Sourcewell and Participating Entities.

20. BANKRUPTCY, DEBARMENT, OR SUSPENSION CERTIFICATION

Supplier certifies and warrants that it is not in bankruptcy or that it has previously disclosed in writing certain information to Sourcewell related to bankruptcy actions. If at any time during this Contract Supplier declares bankruptcy, Supplier must immediately notify Sourcewell in writing.

Supplier certifies and warrants that neither it nor its principals are presently debarred, suspended, proposed for debarment, declared ineligible, or voluntarily excluded from programs operated by the State of Minnesota; the United States federal government or the Canadian government, as applicable; or any Participating Entity. Supplier certifies and warrants that neither it nor its principals have been convicted of a criminal offense related to the subject matter of this Contract. Supplier further warrants that it will provide immediate written notice to Sourcewell if this certification changes at any time.

21. PROVISIONS FOR NON-UNITED STATES FEDERAL ENTITY PROCUREMENTS UNDER UNITED STATES FEDERAL AWARDS OR OTHER AWARDS

Participating Entities that use United States federal grant or FEMA funds to purchase goods or services from this Contract may be subject to additional requirements including the procurement standards of the Uniform Administrative Requirements, Cost Principles and Audit Requirements for Federal Awards, 2 C.F.R. § 200. Participating Entities may have additional requirements based on specific funding source terms or conditions. Within this Article, all references to “federal” should be interpreted to mean the United States federal government. The following list only applies when a Participating Entity accesses Supplier’s Equipment, Products, or Services with United States federal funds.

A. **EQUAL EMPLOYMENT OPPORTUNITY.** Except as otherwise provided under 41 C.F.R. § 60, all contracts that meet the definition of “federally assisted construction contract” in 41 C.F.R. § 60-1.3 must include the equal opportunity clause provided under 41 C.F.R. §60-1.4(b), in accordance with Executive Order 11246, “Equal Employment Opportunity” (30 FR 12319, 12935, 3 C.F.R. §, 1964-1965 Comp., p. 339), as amended by Executive Order 11375, “Amending Executive Order 11246 Relating to Equal Employment Opportunity,” and implementing regulations at 41 C.F.R. § 60, “Office of Federal Contract Compliance Programs, Equal Employment Opportunity, Department of Labor.” The equal opportunity clause is incorporated herein by reference.

B. **DAVIS-BACON ACT, AS AMENDED (40 U.S.C. § 3141-3148).** When required by federal program legislation, all prime construction contracts in excess of \$2,000 awarded by non-federal entities must include a provision for compliance with the Davis-Bacon Act (40 U.S.C. § 3141-3144, and 3146-3148) as supplemented by Department of Labor regulations (29 C.F.R. § 5, “Labor Standards Provisions Applicable to Contracts Covering Federally Financed and Assisted Construction”). In accordance with the statute, contractors must be required to pay wages to laborers and mechanics at a rate not less than the prevailing wages specified in a wage determination made by the Secretary of Labor. In addition, contractors must be required to pay wages not less than once a week. The non-federal entity must place a copy of the current prevailing wage determination issued by the Department of Labor in each solicitation. The decision to award a contract or subcontract must be conditioned upon the acceptance of the wage determination. The non-federal entity must report all suspected or reported violations to the federal awarding agency. The contracts must also include a provision for compliance with the Copeland “Anti-Kickback” Act (40 U.S.C. § 3145), as supplemented by Department of Labor regulations (29 C.F.R. § 3, “Contractors and Subcontractors on Public Building or Public Work Financed in Whole or in Part by Loans or Grants from the United States”). The Act provides that each contractor or subrecipient must be prohibited from inducing, by any means, any person employed in the construction, completion, or repair of public work, to give up any part of the compensation to which he or she is otherwise entitled. The non-federal entity must report all suspected or reported violations to the federal awarding agency. Supplier must be in compliance with all applicable Davis-Bacon Act provisions.

C. CONTRACT WORK HOURS AND SAFETY STANDARDS ACT (40 U.S.C. § 3701-3708). Where applicable, all contracts awarded by the non-federal entity in excess of \$100,000 that involve the employment of mechanics or laborers must include a provision for compliance with 40 U.S.C. §§ 3702 and 3704, as supplemented by Department of Labor regulations (29 C.F.R. § 5). Under 40 U.S.C. § 3702 of the Act, each contractor must be required to compute the wages of every mechanic and laborer on the basis of a standard work week of 40 hours. Work in excess of the standard work week is permissible provided that the worker is compensated at a rate of not less than one and a half times the basic rate of pay for all hours worked in excess of 40 hours in the work week. The requirements of 40 U.S.C. § 3704 are applicable to construction work and provide that no laborer or mechanic must be required to work in surroundings or under working conditions which are unsanitary, hazardous or dangerous. These requirements do not apply to the purchases of supplies or materials or articles ordinarily available on the open market, or contracts for transportation or transmission of intelligence. This provision is hereby incorporated by reference into this Contract. Supplier certifies that during the term of an award for all contracts by Sourcewell resulting from this procurement process, Supplier must comply with applicable requirements as referenced above.

D. RIGHTS TO INVENTIONS MADE UNDER A CONTRACT OR AGREEMENT. If the federal award meets the definition of “funding agreement” under 37 C.F.R. § 401.2(a) and the recipient or subrecipient wishes to enter into a contract with a small business firm or nonprofit organization regarding the substitution of parties, assignment or performance of experimental, developmental, or research work under that “funding agreement,” the recipient or subrecipient must comply with the requirements of 37 C.F.R. § 401, “Rights to Inventions Made by Nonprofit Organizations and Small Business Firms Under Government Grants, Contracts and Cooperative Agreements,” and any implementing regulations issued by the awarding agency. Supplier certifies that during the term of an award for all contracts by Sourcewell resulting from this procurement process, Supplier must comply with applicable requirements as referenced above.

E. CLEAN AIR ACT (42 U.S.C. § 7401-7671Q.) AND THE FEDERAL WATER POLLUTION CONTROL ACT (33 U.S.C. § 1251-1387). Contracts and subgrants of amounts in excess of \$150,000 require the non-federal award to agree to comply with all applicable standards, orders or regulations issued pursuant to the Clean Air Act (42 U.S.C. § 7401- 7671q) and the Federal Water Pollution Control Act as amended (33 U.S.C. § 1251- 1387). Violations must be reported to the Federal awarding agency and the Regional Office of the Environmental Protection Agency (EPA). Supplier certifies that during the term of this Contract will comply with applicable requirements as referenced above.

F. DEBARMENT AND SUSPENSION (EXECUTIVE ORDERS 12549 AND 12689). A contract award (see 2 C.F.R. § 180.220) must not be made to parties listed on the government wide exclusions in the System for Award Management (SAM), in accordance with the OMB guidelines at 2 C.F.R. §180 that implement Executive Orders 12549 (3 C.F.R. § 1986 Comp., p. 189) and 12689 (3 C.F.R. § 1989 Comp., p. 235), “Debarment and Suspension.” SAM Exclusions contains the names

of parties debarred, suspended, or otherwise excluded by agencies, as well as parties declared ineligible under statutory or regulatory authority other than Executive Order 12549. Supplier certifies that neither it nor its principals are presently debarred, suspended, proposed for debarment, declared ineligible, or voluntarily excluded from participation by any federal department or agency.

G. BYRD ANTI-LOBBYING AMENDMENT, AS AMENDED (31 U.S.C. § 1352). Suppliers must file any required certifications. Suppliers must not have used federal appropriated funds to pay any person or organization for influencing or attempting to influence an officer or employee of any agency, a member of Congress, officer or employee of Congress, or an employee of a member of Congress in connection with obtaining any federal contract, grant, or any other award covered by 31 U.S.C. § 1352. Suppliers must disclose any lobbying with non-federal funds that takes place in connection with obtaining any federal award. Such disclosures are forwarded from tier to tier up to the non-federal award. Suppliers must file all certifications and disclosures required by, and otherwise comply with, the Byrd Anti-Lobbying Amendment (31 U.S.C. § 1352).

H. RECORD RETENTION REQUIREMENTS. To the extent applicable, Supplier must comply with the record retention requirements detailed in 2 C.F.R. § 200.333. The Supplier further certifies that it will retain all records as required by 2 C.F.R. § 200.333 for a period of 3 years after grantees or subgrantees submit final expenditure reports or quarterly or annual financial reports, as applicable, and all other pending matters are closed.

I. ENERGY POLICY AND CONSERVATION ACT COMPLIANCE. To the extent applicable, Supplier must comply with the mandatory standards and policies relating to energy efficiency which are contained in the state energy conservation plan issued in compliance with the Energy Policy and Conservation Act.

J. BUY AMERICAN PROVISIONS COMPLIANCE. Any order requiring Buy American provisions will not be accepted until Supplier confirms in writing it can comply with the specific applicable Buy American clause cited. Purchases made in accordance with the Buy American Act must follow the applicable procurement rules calling for free and open competition.

K. ACCESS TO RECORDS (2 C.F.R. § 200.336). Supplier agrees that duly authorized representatives of a federal agency must have access to any books, documents, papers and records of Supplier that are directly pertinent to Supplier's discharge of its obligations under this Contract for the purpose of making audits, examinations, excerpts, and transcriptions. The right also includes timely and reasonable access to Supplier's personnel for the purpose of interview and discussion relating to such documents.

L. PROCUREMENT OF RECOVERED MATERIALS (2 C.F.R. § 200.322). A non-federal entity that is a state agency or agency of a political subdivision of a state and its contractors must comply with Section 6002 of the Solid Waste Disposal Act, as amended by the Resource Conservation

and Recovery Act. The requirements of Section 6002 include procuring only items designated in guidelines of the Environmental Protection Agency (EPA) at 40 C.F.R. § 247 that contain the highest percentage of recovered materials practicable, consistent with maintaining a satisfactory level of competition, where the purchase price of the item exceeds \$10,000 or the value of the quantity acquired during the preceding fiscal year exceeded \$10,000; procuring solid waste management services in a manner that maximizes energy and resource recovery; and establishing an affirmative procurement program for procurement of recovered materials identified in the EPA guidelines.

M. FEDERAL SEAL(S), LOGOS, AND FLAGS. The Supplier not use the seal(s), logos, crests, or reproductions of flags or likenesses of Federal agency officials without specific pre-approval.

N. NO OBLIGATION BY FEDERAL GOVERNMENT. The U.S. federal government is not a party to this Contract or any purchase by an Participating Entity and is not subject to any obligations or liabilities to the Participating Entity, Supplier, or any other party pertaining to any matter resulting from the Contract or any purchase by an authorized user.

O. PROGRAM FRAUD AND FALSE OR FRAUDULENT STATEMENTS OR RELATED ACTS. The Contractor acknowledges that 31 U.S.C. 38 (Administrative Remedies for False Claims and Statements) applies to the Supplier's actions pertaining to this Contract or any purchase by a Participating Entity.

P. FEDERAL DEBT. The Supplier certifies that it is non-delinquent in its repayment of any federal debt. Examples of relevant debt include delinquent payroll and other taxes, audit disallowance, and benefit overpayments.

Q. CONFLICTS OF INTEREST. The Supplier must notify the U.S. Office of General Services, Sourcewell, and Participating Entity as soon as possible if this Contract or any aspect related to the anticipated work under this Contract raises an actual or potential conflict of interest (as described in 2 C.F.R. Part 200). The Supplier must explain the actual or potential conflict in writing in sufficient detail so that the U.S. Office of General Services, Sourcewell, and Participating Entity are able to assess the actual or potential conflict; and provide any additional information as necessary or requested.

R. U.S. EXECUTIVE ORDER 13224. The Supplier, and its subcontractors, must comply with U.S. Executive Order 13224 and U.S. Laws that prohibit transactions with and provision of resources and support to individuals and organizations associated with terrorism.

S. PROHIBITION ON CERTAIN TELECOMMUNICATIONS AND VIDEO SURVEILLANCE SERVICES OR EQUIPMENT. To the extent applicable, Supplier certifies that during the term of this Contract it will comply with applicable requirements of 2 C.F.R. § 200.216.

T. DOMESTIC PREFERENCES FOR PROCUREMENTS. To the extent applicable, Supplier certifies that during the term of this Contract will comply with applicable requirements of 2 C.F.R. § 200.322.

U. FEDERAL GOVERNMENT REQUIREMENTS STIPULATION. Supplier is a commercial entity and the components, equipment and services to be included by Supplier in its proposal and to be provided in the event of an award are offered on the basis that they constitute commercial items as defined in the Federal Acquisition Regulations ("FAR"). Similarly, the prices to be offered by Supplier in its proposal, and which would be offered in any resulting contract and any modifications or changes to such contract are based on Supplier's standard commercial accounting policies and practices. Supplier's accounting practices comply fully with U.S. GAAP, but do not take into account any additional or special requirements of Cost Accounting Standards, nor meet the requirements of FAR Part 31 or any similar procurement regulations, including those of the U.S. Department of Defense. Accordingly, Supplier makes its proposal based on its belief that an award can be made to Supplier consistent with FAR Part 12 - "Acquisition of Commercial Items," and that submission of cost and pricing data consistent with CAS/FAR Part 31 will not be required. Supplier does not accept and will not be held liable for any flow down requirements unless specifically agreed to in writing.

22. CANCELLATION

Sourcewell or Supplier may cancel this Contract at any time, with or without cause, upon 60 days' written notice to the other party. However, Sourcewell may cancel this Contract immediately upon discovery of a material defect in any certification made in Supplier's Proposal. Cancellation of this Contract does not relieve either party of financial, product, or service obligations incurred or accrued prior to cancellation.

Sourcewell

Carrier Global Corporation

DocuSigned by:
Jeremy Schwartz
C0FD2A139D06489...

DocuSigned by:
Simon C. Walls
F1B5CDFCEE8A47B...

By: _____

By: _____

Jeremy Schwartz

Simon C. Walls

Title: Chief Procurement Officer

Title: Global Strategic Accounts Leader

10/7/2021 | 9:30 PM CDT

10/7/2021 | 11:01 AM CDT

Date: _____

Date: _____

Approved:

DocuSigned by:
Chad Coauette
7E42B8F817A64CC...

By: _____

Chad Coauette

Title: Executive Director/CEO

10/7/2021 | 9:34 PM CDT

Date: _____

**AMENDMENT #1
TO
CONTRACT #070121-CAR**

THIS AMENDMENT is effective upon the date of the last signature below by and between **Sourcewell** and **Carrier Global Corporation** (Supplier).

Sourcewell awarded a contract to Supplier to provide HVAC Systems and Related Services, effective October 7, 2021, through August 12, 2025 (Contract).

Supplier requested that its name be modified from the name of its holding company to its North American operating company "Carrier Corporation."

All references to "Carrier Global Corporation" in Contract #070121-CAR will be stricken and replaced with "Carrier Corporation."

Except as amended above, the Contract remains in full force and effect.

Sourcewell

Carrier Global Corporation

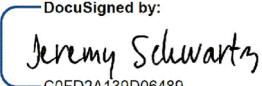
By: 
C0FD2A139D06489...
Jeremy Schwartz, Chief Procurement Officer

By: 
Will Langston, Assistant Secretary

Date: 4/15/2022 | 6:24 AM CDT

Date: April 19, 2022

Approved:

By: 
7E42B8F817A64CC...
Chad Coquette, Executive Director/CEO

Date: 4/15/2022 | 6:46 AM CDT

**CITY OF ARCADIA
CONSTRUCTION CONTRACT
LIBRARY HVAC UNITS REPLACEMENT PROJECT**

1. PARTIES AND DATE.

This Contract is made and entered into this _____ day of _____, 2024 by and between the City of Arcadia, a public agency of the State of California (“City”) and **Carrier Corporation**, a **Delaware Corporation**, with its principal place of business at 2478 Peck Road, City of Industry, CA 90601 (“Contractor”). City and Contractor are sometimes individually referred to as “Party” and collectively as “Parties” in this Contract.

2. RECITALS.

2.1 City. City is a public agency organized under the laws of the State of California, with power to contract for services necessary to achieve its purpose.

2.2 Contractor. Contractor desires to perform and assume responsibility for the provision of certain construction services required by the City on the terms and conditions set forth in this Contract. Contractor represents that it is duly licensed and experienced in providing **heating, ventilation, air conditioning, repair and replacement for HVAC** related construction services to public clients, that it and its employees or subcontractors have all necessary licenses and permits to perform the services in the State of California, and that it is familiar with the plans of City. The following license classifications are required for this Project: **C-20 and C-10**.

2.3 Project. City desires to engage Contractor to render such services for the **Library HVAC Units Replacement Project** (“Project”) as set forth in this Contract.

2.4 Project Documents & Certifications. Contractor has obtained, and delivers concurrently herewith, a performance bond, a payment bond, and all insurance documentation, as required by the Contract.

3. TERMS

3.1 Incorporation of Documents. This Contract includes and hereby incorporates in full by reference the following documents, including all exhibits, drawings, specifications and documents therein, and attachments and addenda thereto:

- Services/Schedule (Exhibit “A”)
- Plans and Specifications (Exhibit “B”)
- Special Conditions (Exhibit “C”)
- Contractor’s Certificate Regarding Workers’ Compensation (Exhibit “D”)
- Public Works Contractor Registration Certification (Exhibit “E”)
- Payment and Performance Bonds (Exhibit “F”)
- Federal Requirements (Exhibit “G”)
- Addenda
- Change Orders executed by the City
- **Current** Edition of the Standard Specifications for Public Works Construction (The Greenbook), Excluding Sections 1-9
- Notice Inviting Bids, if any

- Instructions to Bidders, if any
- Contractor's Bid

3.2 Contractor's Basic Obligation; Scope of Work. Contractor promises and agrees, at its own cost and expense, to furnish to the City all labor, materials, tools, equipment, services, and incidental and customary work necessary to fully and adequately complete the Project, including all structures and facilities necessary for the Project or described in the Contract (hereinafter sometimes referred to as the "Work"), for a Total Contract Price as specified pursuant to this Contract. All Work shall be subject to, and performed in accordance with the above referenced documents, as well as the exhibits attached hereto and incorporated herein by reference. The plans and specifications for the Work are further described in Exhibit "B" attached hereto and incorporated herein by this reference. Special Conditions, if any, relating to the Work are described in Exhibit "C" attached hereto and incorporated herein by this reference.

3.2.1 Change in Scope of Work. Any change in the scope of the Work, method of performance, nature of materials or price thereof, or any other matter materially affecting the performance or nature of the Work shall not be paid for or accepted unless such change, addition or deletion is approved in writing by a valid change order executed by the City. Should Contractor request a change order due to unforeseen circumstances affecting the performance of the Work, such request shall be made within five (5) business days of the date such circumstances are discovered or shall waive its right to request a change order due to such circumstances. If the Parties cannot agree on any change in price required by such change in the Work, the City may direct the Contractor to proceed with the performance of the change on a time and materials basis.

3.2.2 Substitutions/"Or Equal". Pursuant to Public Contract Code Section 3400(b), the City may make a finding that designates certain products, things, or services by specific brand or trade name. Unless specifically designated in this Contract, whenever any material, process, or article is indicated or specified by grade, patent, or proprietary name or by name of manufacturer, such Specifications shall be deemed to be used for the purpose of facilitating the description of the material, process or article desired and shall be deemed to be followed by the words "or equal."

Contractor may, unless otherwise stated, offer for substitution any material, process or article which shall be substantially equal or better in every respect to that so indicated or specified in this Contract. However, the City may have adopted certain uniform standards for certain materials, processes and articles. Contractor shall submit requests, together with substantiating data, for substitution of any "or equal" material, process or article no later than thirty-five (35) days after award of the Contract. To facilitate the construction schedule and sequencing, some requests may need to be submitted before thirty-five (35) days after award of Contract. Provisions regarding submission of "or equal" requests shall not in any way authorize an extension of time for performance of this Contract. If a proposed "or equal" substitution request is rejected, Contractor shall be responsible for providing the specified material, process or article. The burden of proof as to the equality of any material, process or article shall rest with Contractor.

The City has the complete and sole discretion to determine if a material, process or article is an "or equal" material, process or article that may be substituted. Data required to substantiate requests for substitutions of an "or equal" material, process or article data shall include a signed affidavit from Contractor stating that, and describing how, the substituted "or equal" material, process or article is equivalent to that specified in every way except as listed on

the affidavit. Substantiating data shall include any and all illustrations, specifications, and other relevant data including catalog information which describes the requested substituted "or equal" material, process or article, and substantiates that it is an "or equal" to the material, process or article. The substantiating data must also include information regarding the durability and lifecycle cost of the requested substituted "or equal" material, process or article. Failure to submit all the required substantiating data, including the signed affidavit, to the City in a timely fashion will result in the rejection of the proposed substitution.

Contractor shall bear all of the City's costs associated with the review of substitution requests. Contractor shall be responsible for all costs related to a substituted "or equal" material, process or article. Contractor is directed to the Special Conditions (if any) to review any findings made pursuant to Public Contract Code section 3400.

3.3 Period of Performance and Liquidated Damages. Contractor shall perform and complete all Work under this Contract within **Forty-Five (45) calendar** days, beginning the effective date of the Notice to Proceed ("Contract Time"). Contractor shall perform its Work in strict accordance with any completion schedule, construction schedule or project milestones developed by the City. Such schedules or milestones may be included as part of Exhibits "A" or "B" attached hereto, or may be provided separately in writing to Contractor. Contractor agrees that if such Work is not completed within the aforementioned Contract Time and/or pursuant to any such completion schedule, construction schedule or project milestones developed pursuant to provisions of the Contract, it is understood, acknowledged and agreed that the City will suffer damage. Pursuant to Government Code Section 53069.85, Contractor shall pay to the City as fixed and liquidated damages the sum of **Four Hundred Dollars and No Cents (\$400.00)** per day for each and every calendar day of delay beyond the Contract Time or beyond any completion schedule, construction schedule or Project milestones established pursuant to the Contract.

3.4 Standard of Performance; Performance of Employees. Contractor shall perform all Work under this Contract in a skillful and workmanlike manner, and consistent with the standards generally recognized as being employed by professionals in the same discipline in the State of California. Contractor represents and maintains that it is skilled in the professional calling necessary to perform the Work. Contractor warrants that all employees and subcontractors shall have sufficient skill and experience to perform the Work assigned to them. Finally, Contractor represents that it, its employees and subcontractors have all licenses, permits, qualifications and approvals of whatever nature that are legally required to perform the Work, including any required business license, and that such licenses and approvals shall be maintained throughout the term of this Contract. As provided for in the indemnification provisions of this Contract, Contractor shall perform, at its own cost and expense and without reimbursement from the City, any work necessary to correct errors or omissions which are caused by Contractor's failure to comply with the standard of care provided for herein. Any employee who is determined by the City to be uncooperative, incompetent, a threat to the safety of persons or the Work, or any employee who fails or refuses to perform the Work in a manner acceptable to the City, shall be promptly removed from the Project by Contractor and shall not be re-employed on the Work.

3.5 Control and Payment of Subordinates; Contractual Relationship. City retains Contractor on an independent contractor basis and Contractor is not an employee of City. Any additional personnel performing the work governed by this Contract on behalf of Contractor shall at all times be under Contractor's exclusive direction and control. Contractor shall pay all wages, salaries, and other amounts due such personnel in connection with their performance under this Contract and as required by law. Contractor shall be responsible for all reports and

obligations respecting such additional personnel, including, but not limited to: social security taxes, income tax withholding, unemployment insurance, and workers' compensation insurance.

3.6 City's Basic Obligation. City agrees to engage and does hereby engage Contractor as an independent contractor to furnish all materials and to perform all Work according to the terms and conditions herein contained for the sum set forth above. Except as otherwise provided in the Contract, the City shall pay to Contractor, as full consideration for the satisfactory performance by Contractor of the services and obligations required by this Contract, the below-referenced compensation in accordance with compensation provisions set forth in the Contract.

3.7 Compensation and Payment.

3.7.1 Amount of Compensation. As consideration for performance of the Work required herein, City agrees to pay Contractor the Total Contract Price of **ONE HUNDRED FORTY THOUSAND, FOUR HUNDRED SIXTY-NINE DOLLARS AND NO CENTS (\$140,469.00)** ("Total Contract Price") provided that such amount shall be subject to adjustment pursuant to the applicable terms of this Contract or written change orders approved and signed in advance by the City.

3.7.2 Payment of Compensation. If the Work is scheduled for completion in thirty (30) or less calendar days, City will arrange for payment of the Total Contract Price upon completion and approval by City of the Work. If the Work is scheduled for completion in more than thirty (30) calendar days, City will pay Contractor on a monthly basis as provided for herein. On or before the fifth (5th) day of each month, Contractor shall submit to the City an itemized application for payment in the format supplied by the City indicating the amount of Work completed since commencement of the Work or since the last progress payment. These applications shall be supported by evidence which is required by this Contract and such other documentation as the City may require. The Contractor shall certify that the Work for which payment is requested has been done and that the materials listed are stored where indicated. Contractor may be required to furnish a detailed schedule of values upon request of the City and in such detail and form as the City shall request, showing the quantities, unit prices, overhead, profit, and all other expenses involved in order to provide a basis for determining the amount of progress payments.

3.7.3 Prompt Payment. City shall review and pay all progress payment requests in accordance with the provisions set forth in Section 20104.50 of the California Public Contract Code. However, no progress payments will be made for Work not completed in accordance with this Contract. Contractor shall comply with all applicable laws, rules and regulations relating to the proper payment of its employees, subcontractors, suppliers or others.

3.7.4 Contract Retentions. From each approved progress estimate, five percent (5%) will be deducted and retained by the City, and the remainder will be paid to Contractor. All Contract retention shall be released and paid to Contractor and subcontractors pursuant to California Public Contract Code Section 7107.

3.7.5 Other Retentions. In addition to Contract retentions, the City may deduct from each progress payment an amount necessary to protect City from loss because of: (1) liquidated damages which have accrued as of the date of the application for payment; (2) any sums expended by the City in performing any of Contractor's obligations under the Contract which Contractor has failed to perform or has performed inadequately; (3) defective Work not remedied; (4) stop notices as allowed by state law; (5) reasonable doubt that the Work can be completed for the unpaid balance of the Total Contract Price or within the scheduled completion

date; (6) unsatisfactory prosecution of the Work by Contractor; (7) unauthorized deviations from the Contract; (8) failure of Contractor to maintain or submit on a timely basis proper and sufficient documentation as required by the Contract or by City during the prosecution of the Work; (9) erroneous or false estimates by Contractor of the value of the Work performed; (10) any sums representing expenses, losses, or damages as determined by the City, incurred by the City for which Contractor is liable under the Contract; and (11) any other sums which the City is entitled to recover from Contractor under the terms of the Contract or pursuant to state law, including Section 1727 of the California Labor Code. The failure by the City to deduct any of these sums from a progress payment shall not constitute a waiver of the City's right to such sums.

3.7.6 Substitutions for Contract Retentions. In accordance with California Public Contract Code Section 22300, the City will permit the substitution of securities for any monies withheld by the City to ensure performance under the Contract. At the request and expense of Contractor, securities equivalent to the amount withheld shall be deposited with the City, or with a state or federally chartered bank in California as the escrow agent, and thereafter the City shall then pay such monies to Contractor as they come due. Upon satisfactory completion of the Contract, the securities shall be returned to Contractor. For purposes of this Section and Section 22300 of the Public Contract Code, the term "satisfactory completion of the contract" shall mean the time the City has issued written final acceptance of the Work and filed a Notice of Completion as required by law and provisions of this Contract. Contractor shall be the beneficial owner of any securities substituted for monies withheld and shall receive any interest thereon. The escrow agreement used for the purposes of this Section shall be in the form provided by the City.

3.7.7 Title to Work. As security for partial, progress, or other payments, title to Work for which such payments are made shall pass to the City at the time of payment. To the extent that title has not previously been vested in the City by reason of payments, full title shall pass to the City at delivery of the Work at the destination and time specified in this Contract. Such transferred title shall in each case be good, free and clear from any and all security interests, liens, or other encumbrances. Contractor promises and agrees that it will not pledge, hypothecate, or otherwise encumber the items in any manner that would result in any lien, security interest, charge, or claim upon or against said items. Such transfer of title shall not imply acceptance by the City, nor relieve Contractor from the responsibility to strictly comply with the Contract, and shall not relieve Contractor of responsibility for any loss of or damage to items.

3.7.8 Labor and Material Releases. Contractor shall furnish City with labor and material releases from all subcontractors performing work on, or furnishing materials for, the Work governed by this Contract prior to final payment by City.

3.7.9 Prevailing Wages. Contractor is aware of the requirements of California Labor Code Section 1720 et seq., and 1770 et seq., as well as California Code of Regulations, Title 8, Section 16000 et seq., ("Prevailing Wage Laws"), which require the payment of prevailing wage rates and the performance of other requirements on "public works" and "maintenance" projects. Since the Services are being performed as part of an applicable "public works" or "maintenance" project, as defined by the Prevailing Wage Laws, and if the total compensation is \$25,000 or more, Contractor agrees to fully comply with such Prevailing Wage Laws. City shall provide Contractor with a copy of the prevailing rates of per diem wages in effect at the commencement of this Contract. Contractor shall make copies of the prevailing rates of per diem wages for each craft, classification or type of worker needed to execute the Services available to interested parties upon request, and shall post copies at Contractor's

principal place of business and at the project site. Contractor shall defend, indemnify and hold the City, its officials, officers, employees and agents free and harmless from any claim or liability arising out of any failure or alleged failure to comply with the Prevailing Wage Laws. Contractor and any subcontractor shall forfeit a penalty of up to \$200 per calendar day or portion thereof for each worker paid less than the prevailing wage rates.

3.7.10 Apprenticeable Crafts. If the Total Contract Price exceeds \$35,000 and if Contractor employs workmen in an apprenticeable craft or trade, Contractor shall comply with the provisions of Section 1777.5 of the California Labor Code with respect to the employment of properly registered apprentices upon public works. The primary responsibility for compliance with said section for all apprenticeable occupations shall be with Contractor. The Contractor or any subcontractor that is determined by the Labor Commissioner to have knowingly violated Section 1777.5 shall forfeit as a civil penalty an amount not exceeding \$100 for each full calendar day of noncompliance, or such greater amount as provided by law.

3.7.11 Hours of Work. If the Total Contract Price exceeds \$25,000, Contractor is advised that eight (8) hours labor constitutes a legal day's work. Pursuant to Section 1813 of the California Labor Code, Contractor shall forfeit a penalty of \$25.00 per worker for each day that each worker is permitted to work more than eight (8) hours in any one calendar day and forty (40) hours in any one calendar week, except when payment for overtime is made at not less than one and one-half (1-1/2) times the basic rate for that worker.

3.7.12 Payroll Records. If the Total Contract Price exceeds \$25,000, Contractor and each subcontractor shall keep an accurate payroll record, showing the name, address, social security number, work classification, straight time and overtime hours worked each day and week, and the actual per diem wages paid to each journeyman, apprentice, worker, or other employee employed by him or her in connection with the public work. The payroll records shall be certified and shall be available for inspection at all reasonable hours at the principal office of Contractor in the manner provided in Labor Code section 1776. In the event of noncompliance with the requirements of this section, Contractor shall have 10 days in which to comply subsequent to receipt of written notice specifying in what respects such Contractor must comply with this section. Should noncompliance still be evident after such 10-day period, Contractor shall, as a penalty to City, forfeit not more than \$100.00 for each calendar day or portion thereof, for each worker, until strict compliance is effectuated. The amount of the forfeiture is to be determined by the Labor Commissioner. A contractor who is found to have violated the provisions of law regarding wages on Public Works with the intent to defraud shall be ineligible to bid on Public Works contracts for a period of one to three years as determined by the Labor Commissioner. Upon the request of the Division of Apprenticeship Standards or the Division of Labor Standards Enforcement, such penalties shall be withheld from progress payments then due. The responsibility for compliance with this section is on Contractor. The requirement to submit certified payroll records directly to the Labor Commissioner under Labor Code section 1771.4 shall not apply to work performed on a public works project that is exempt pursuant to the small project exemption specified in Labor Code Section 1771.4.

3.7.13 Contractor and Subcontractor Registration. If the Total Contract Price exceeds \$25,000, then pursuant to Labor Code sections 1725.5 and 1771.1, all contractors and subcontractors that wish to bid on, be listed in a bid proposal, or enter into a contract to perform public work must be registered with the Department of Industrial Relations. No bid will be accepted nor any contract entered into without proof of the contractor's and subcontractors' current registration with the Department of Industrial Relations to perform public work. Contractor is directed to review, fill out and execute the Public Works Contractor Registration Certification attached hereto as Exhibit "E" prior to contract execution. Notwithstanding the

foregoing, the contractor registration requirements mandated by Labor Code Sections 1725.5 and 1771.1 shall not apply to work performed on a public works project that is exempt pursuant to the small project exemption specified in Labor Code Sections 1725.5 and 1771.1.

3.7.14 Labor Compliance; Stop Orders. If the Total Contract Price exceeds \$25,000, Contractor acknowledges that it is aware that this Project is subject to compliance monitoring and enforcement by the Department of Industrial Relations. It shall be the Contractor's sole responsibility to evaluate and pay the cost of complying with all labor compliance requirements under this Contract and applicable law. Any stop orders issued by the Department of Industrial Relations against Contractor or any subcontractor that affect Contractor's performance of Work, including any delay, shall be Contractor's sole responsibility. Any delay arising out of or resulting from such stop orders shall be considered Contractor caused delay subject to any applicable liquidated damages and shall not be compensable by the City. Contractor shall defend, indemnify and hold the City, its officials, officers, employees and agents free and harmless from any claim or liability arising out of stop orders issued by the Department of Industrial Relations against Contractor or any subcontractor.

3.8 Performance of Work; Jobsite Obligations.

3.8.1 Water Quality Management and Compliance.

3.8.1.1 Water Quality Management and Compliance. Contractor shall keep itself and all subcontractors, staff, and employees fully informed of and in compliance with all local, state and federal laws, rules and regulations that may impact, or be implicated by the performance of the Work including, without limitation, all applicable provisions of the Federal Water Pollution Control Act (33 U.S.C. §§ 1300); the California Porter-Cologne Water Quality Control Act (Cal Water Code §§ 13000-14950); local ordinances regulating discharges of storm water; and any and all regulations, policies, or permits issued pursuant to any such authority regulating the discharge of pollutants, as that term is used in the Porter-Cologne Water Quality Control Act, to any ground or surface water in the State.

3.8.1.2 Compliance with the Statewide Construction General Permit. Contractor shall comply with all conditions of the most recent iteration of the National Pollutant Discharge Elimination System General Permit for Storm Water Discharges Associated with Construction Activity, issued by the California State Water Resources Control Board ("Permit"). It shall be Contractor's sole responsibility to file a Notice of Intent and procure coverage under the Permit for all construction activity which results in the disturbance of more than one acre of total land area or which is part of a larger common area of development or sale. Prior to initiating work, Contractor shall be solely responsible for preparing and implementing a Storm Water Pollution Prevention Plan (SWPPP) as required by the Permit. Contractor shall be responsible for procuring, implementing and complying with the provisions of the Permit and the SWPPP, including the standard provisions, and monitoring and reporting requirements as required by the Permit. The Permit requires the SWPPP to be a "living document" that changes as necessary to meet the conditions and requirements of the job site as it progresses through difference phases of construction and is subject to different weather conditions. It shall be Contractor's sole responsibility to update the SWPPP as necessary to address conditions at the project site.

3.8.1.3 Other Water Quality Rules Regulations and Policies. Contractor shall comply with the lawful requirements of any applicable municipality, drainage City, or local agency regarding discharges of storm water to separate storm drain systems or

other watercourses under their jurisdiction, including applicable requirements in municipal storm water management programs.

3.8.1.4 **Cost of Compliance.** Storm, surface, nuisance, or other waters may be encountered at various times during construction of The Work. Therefore, the Contractor, by submitting a Bid, hereby acknowledges that it has investigated the risk arising from such waters, has prepared its Bid accordingly, and assumes any and all risks and liabilities arising therefrom.

3.8.1.5 **Liability for Non-Compliance.** Failure to comply with the Permit is a violation of federal and state law. Pursuant to the indemnification provisions of this Contract, Contractor hereby agrees to defend, indemnify and hold harmless the City and its officials, officers, employees, volunteers and agents for any alleged violations. In addition, City may seek damages from Contractor for any delay in completing the Work in accordance with the Contract, if such delay is caused by or related to Contractor's failure to comply with the Permit.

3.8.1.6 **Reservation of Right to Defend.** City reserves the right to defend any enforcement action brought against the City for Contractor's failure to comply with the Permit or any other relevant water quality law, regulation, or policy. Pursuant to the indemnification provisions of this Contract, Contractor hereby agrees to be bound by, and to reimburse the City for the costs (including the City's attorney's fees) associated with, any settlement reached between the City and the relevant enforcement entity.

3.8.1.7 **Training.** In addition to the standard of performance requirements set forth in paragraph 3.4, Contractor warrants that all employees and subcontractors shall have sufficient skill and experience to perform the Work assigned to them without impacting water quality in violation of the laws, regulations and policies described in paragraph 3.8.1. Contractor further warrants that it, its employees and subcontractors will receive adequate training, as determined by City, regarding the requirements of the laws, regulations and policies described in paragraph 3.8.1 as they may relate to the Work provided under this Agreement. Upon request, City will provide the Contractor with a list of training programs that meet the requirements of this paragraph.

3.8.2 **Safety.** Contractor shall execute and maintain its work so as to avoid injury or damage to any person or property. Contractor shall comply with the requirements of the specifications relating to safety measures applicable in particular operations or kinds of work. In carrying out its Work, Contractor shall at all times be in compliance with all applicable local, state and federal laws, rules and regulations, and shall exercise all necessary precautions for the safety of employees appropriate to the nature of the Work and the conditions under which the Work is to be performed. Safety precautions as applicable shall include, but shall not be limited to, adequate life protection and lifesaving equipment; adequate illumination for underground and night operations; instructions in accident prevention for all employees, such as machinery guards, safe walkways, scaffolds, ladders, bridges, gang planks, confined space procedures, trenching and shoring, fall protection and other safety devices, equipment and wearing apparel as are necessary or lawfully required to prevent accidents or injuries; and adequate facilities for the proper inspection and maintenance of all safety measures. Furthermore, Contractor shall prominently display the names and telephone numbers of at least two medical doctors practicing in the vicinity of the Project, as well as the telephone number of the local ambulance service, adjacent to all telephones at the Project site.

3.8.3 **Laws and Regulations.** Contractor shall keep itself fully informed of and in compliance with all local, state and federal laws, rules and regulations in any manner

affecting the performance of the Contract or the Work, including all Cal/OSHA requirements, and shall give all notices required by law. Contractor shall be liable for all violations of such laws and regulations in connection with Work. If Contractor observes that the drawings or specifications are at variance with any law, rule or regulation, it shall promptly notify the City in writing. Any necessary changes shall be made by written change order. If Contractor performs any work knowing it to be contrary to such laws, rules and regulations and without giving written notice to the City, Contractor shall be solely responsible for all costs arising therefrom. City is a public entity of the State of California subject to certain provisions of the Health & Safety Code, Government Code, Public Contract Code, and Labor Code of the State. It is stipulated and agreed that all provisions of the law applicable to the public contracts of a municipality are a part of this Contract to the same extent as though set forth herein and will be complied with. Contractor shall defend, indemnify and hold City, its officials, officers, employees and agents free and harmless, pursuant to the indemnification provisions of this Contract, from any claim or liability arising out of any failure or alleged failure to comply with such laws, rules or regulations.

3.8.4 Permits and Licenses. Contractor shall be responsible for securing City permits and licenses necessary to perform the Work described herein, including, but not limited to, any required business license. While Contractor will not be charged a fee for any City permits, Contractor shall pay the City's business license fee, if any. Any ineligible contractor or subcontractor pursuant to Labor Code Sections 1777.1 and 1777.7 may not perform work on this Project.

3.8.5 Trenching Work. If the Total Contract Price exceeds \$25,000 and if the Work governed by this Contract entails excavation of any trench or trenches five (5) feet or more in depth, Contractor shall comply with all applicable provisions of the California Labor Code, including Section 6705. To this end, Contractor shall submit for City's review and approval a detailed plan showing the design of shoring, bracing, sloping, or other provisions to be made for worker protection from the hazard of caving ground during the excavation of such trench or trenches. If such plan varies from the shoring system standards, the plan shall be prepared by a registered civil or structural engineer.

3.8.6 Hazardous Materials and Differing Conditions. As required by California Public Contract Code Section 7104, if this Contract involves digging trenches or other excavations that extend deeper than four (4) feet below the surface, Contractor shall promptly, and prior to disturbance of any conditions, notify City of: (1) any material discovered in excavation that Contractor believes to be a hazardous waste that is required to be removed to a Class I, Class II or Class III disposal site; (2) subsurface or latent physical conditions at the site differing from those indicated by City; and (3) unknown physical conditions of an unusual nature at the site, significantly different from those ordinarily encountered in such contract work. Upon notification, City shall promptly investigate the conditions to determine whether a change order is appropriate. In the event of a dispute, Contractor shall not be excused from any scheduled completion date and shall proceed with all Work to be performed under the Contract, but shall retain all rights provided by the Contract or by law for making protests and resolving the dispute.

3.8.7 Underground Utility Facilities. To the extent required by Section 4215 of the California Government Code, City shall compensate Contractor for the costs of: (1) locating and repairing damage to underground utility facilities not caused by the failure of Contractor to exercise reasonable care; (2) removing or relocating underground utility facilities not indicated in the construction drawings; and (3) equipment necessarily idled during such work. Contractor shall not be assessed liquidated damages for delay caused by failure of City to provide for removal or relocation of such utility facilities.

3.8.8 Air Quality. Contractor must fully comply with all applicable laws, rules and regulations in furnishing or using equipment and/or providing services, including, but not limited to, emissions limits and permitting requirements imposed by the California Air Resources Board (CARB). Although CARB limits and requirements are more broad, Contractor shall specifically be aware of their application to "portable equipment", which definition is considered by CARB to include any item of equipment with a fuel-powered engine. Contractor shall indemnify City against any fines or penalties imposed by CARB, or any other governmental or regulatory agency for violations of applicable laws, rules and/or regulations by Contractor, its subcontractors, or others for whom Contractor is responsible under its indemnity obligations provided for in this Agreement.

3.8.9 State Recycling Mandates. Contractor shall comply with State Recycling Mandates. Any recyclable materials/debris collected by the contractor that can be feasibly diverted via reuse or recycling must be hauled by the appropriate handler for reuse or recycling.

3.9 Completion of Work. When Contractor determines that it has completed the Work required herein, Contractor shall so notify City in writing and shall furnish all labor and material releases required by this Contract. City shall thereupon inspect the Work. If the Work is not acceptable to the City, the City shall indicate to Contractor in writing the specific portions or items of Work which are unsatisfactory or incomplete. Once Contractor determines that it has completed the incomplete or unsatisfactory Work, Contractor may request a reinspection by the City. Once the Work is acceptable to City, City shall pay to Contractor the Total Contract Price remaining to be paid, less any amount which City may be authorized or directed by law to retain. Payment of retention proceeds due to Contractor shall be made in accordance with Section 7107 of the California Public Contract Code.

3.10 Claims; Government Code Claim Compliance.

3.10.1 Intent. Effective January 1, 1991, Section 20104 et seq., of the California Public Contract Code prescribes a process utilizing informal conferences, non-binding judicial supervised mediation, and judicial arbitration to resolve disputes on construction claims of \$375,000 or less. Effective January 1, 2017, Section 9204 of the Public Contract Code prescribes a process for negotiation and mediation to resolve disputes on construction claims. The intent of this Section is to implement Sections 20104 et seq. and Section 9204 of the California Public Contract Code. This Section shall be construed to be consistent with said statutes.

3.10.2 Claims. For purposes of this Section, "Claim" means a separate demand by the Contractor, after a change order duly requested in accordance with the terms of this Contract has been denied by the City, for (A) a time extension, (B) payment of money or damages arising from Work done by or on behalf of the Contractor pursuant to the Contract, or (C) an amount the payment of which is disputed by the City. Claims governed by this Section may not be filed unless and until the Contractor completes all procedures for giving notice of delay or change and for the requesting of a time extension or change order, including but not necessarily limited to the change order procedures contained herein, and Contractor's request for a change has been denied in whole or in part. Claims governed by this Section must be filed no later than fourteen (14) days after a request for change has been denied in whole or in part or after any other event giving rise to the Claim. The Claim shall be submitted in writing to the City and shall include on its first page the following in 16 point capital font: "THIS IS A CLAIM." Furthermore, the claim shall include the documents necessary to substantiate the claim. Nothing in this Section is intended to extend the time limit or supersede notice requirements

otherwise provided by contract for the filing of claims, including all requirements pertaining to compensation or payment for extra Work, disputed Work, and/or changed conditions. Failure to follow such contractual requirements shall bar any claims or subsequent lawsuits for compensation or payment thereon.

3.10.3 Supporting Documentation. The Contractor shall submit all claims in the following format:

3.10.3.1 Summary of claim merit and price, reference Contract Document provisions pursuant to which the claim is made

3.10.3.2 List of documents relating to claim:

- (A) Specifications
- (B) Drawings
- (C) Clarifications (Requests for Information)
- (D) Schedules
- (E) Other

3.10.3.3 Chronology of events and correspondence

3.10.3.4 Analysis of claim merit

3.10.3.5 Analysis of claim cost

3.10.3.6 Time impact analysis in CPM format

3.10.3.7 If Contractor's claim is based in whole or in part on an allegation of errors or omissions in the Drawings or Specifications for the Project, Contractor shall provide a summary of the percentage of the claim subject to design errors or omissions and shall obtain a certificate of merit in support of the claim of design errors and omissions.

3.10.3.8 Cover letter and certification of validity of the claim, including any claims from subcontractors of any tier, in accordance with Government Code section 12650 *et seq.*

3.10.4 City's Response. Upon receipt of a claim pursuant to this Section, City shall conduct a reasonable review of the claim and, within a period not to exceed 45 days, shall provide the Contractor a written statement identifying what portion of the claim is disputed and what portion is undisputed. Any payment due on an undisputed portion of the claim will be processed and made within 60 days after the public entity issues its written statement.

3.10.4.1 If City needs approval from its governing body to provide the Contractor a written statement identifying the disputed portion and the undisputed portion of the claim, and the governing body does not meet within the 45 days or within the mutually agreed to extension of time following receipt of a claim sent by registered mail or certified mail, return receipt requested, City shall have up to three days following the next duly publicly noticed meeting of the governing body after the 45-day period, or extension, expires to provide the Contractor a written statement identifying the disputed portion and the undisputed portion.

3.10.4.2 Within 30 days of receipt of a claim, City may request in writing additional documentation supporting the claim or relating to defenses or claims City may have against the Contractor. If additional information is thereafter required, it shall be requested and provided pursuant to this subdivision, upon mutual agreement of City and the Contractor.

3.10.4.3 City's written response to the claim, as further documented, shall be submitted to the Contractor within 30 days (if the claim is less than \$50,000, within 15 days) after receipt of the further documentation, or within a period of time no greater than that taken by the Contractor in producing the additional information or requested documentation, whichever is greater.

3.10.5 Meet and Confer. If the Contractor disputes City's written response, or City fails to respond within the time prescribed, the Contractor may so notify City, in writing, either within 15 days of receipt of City's response or within 15 days of City's failure to respond within the time prescribed, respectively, and demand an informal conference to meet and confer for settlement of the issues in dispute. Upon receipt of a demand, City shall schedule a meet and confer conference within 30 days for settlement of the dispute.

3.10.6 Mediation. Within 10 business days following the conclusion of the meet and confer conference, if the claim or any portion of the claim remains in dispute, City shall provide the Contractor a written statement identifying the portion of the claim that remains in dispute and the portion that is undisputed. Any payment due on an undisputed portion of the claim shall be processed and made within 60 days after City issues its written statement. Any disputed portion of the claim, as identified by the Contractor in writing, shall be submitted to nonbinding mediation, with City and the Contractor sharing the associated costs equally. City and Contractor shall mutually agree to a mediator within 10 business days after the disputed portion of the claim has been identified in writing, unless the parties agree to select a mediator at a later time.

3.10.6.1 If the Parties cannot agree upon a mediator, each Party shall select a mediator and those mediators shall select a qualified neutral third party to mediate with regard to the disputed portion of the claim. Each Party shall bear the fees and costs charged by its respective mediator in connection with the selection of the neutral mediator.

3.10.6.2 For purposes of this section, mediation includes any nonbinding process, including, but not limited to, neutral evaluation or a dispute review board, in which an independent third party or board assists the Parties in dispute resolution through negotiation or by issuance of an evaluation. Any mediation utilized shall conform to the timeframes in this section.

3.10.6.3 Unless otherwise agreed to by City and the Contractor in writing, the mediation conducted pursuant to this section shall excuse any further obligation under Section 20104.4 to mediate after litigation has been commenced.

3.10.6.4 The mediation shall be held no earlier than the date the Contractor completes the Work or the date that the Contractor last performs Work, whichever is earlier. All unresolved claims shall be considered jointly in a single mediation, unless a new unrelated claim arises after mediation is completed.

3.10.7 Procedures After Mediation. If following the mediation, the claim or any portion remains in dispute, the Contractor must file a claim pursuant to Chapter 1 (commencing with Section 900) and Chapter 2 (commencing with Section 910) of Part 3 of Division 3.6 of Title 1 of the Government Code. For purposes of those provisions, the running of the period of time

within which a claim must be filed shall be tolled from the time the Contractor submits his or her written claim pursuant to subdivision (a) until the time the claim is denied, including any period of time utilized by the meet and confer conference or mediation.

3.10.8 Civil Actions. The following procedures are established for all civil actions filed to resolve claims subject to this Section:

3.10.8.1 Within 60 days, but no earlier than 30 days, following the filing or responsive pleadings, the court shall submit the matter to non-binding mediation unless waived by mutual stipulation of both parties or unless mediation was held prior to commencement of the action in accordance with Public Contract Code section 9204 and the terms of these procedures.. The mediation process shall provide for the selection within 15 days by both parties of a disinterested third person as mediator, shall be commenced within 30 days of the submittal, and shall be concluded within 15 days from the commencement of the mediation unless a time requirement is extended upon a good cause showing to the court.

3.10.8.2 If the matter remains in dispute, the case shall be submitted to judicial arbitration pursuant to Chapter 2.5 (commencing with Section 1141.10) of Title 3 of Part 3 of the Code of Civil Procedure, notwithstanding Section 1114.11 of that code. The Civil Discovery Act of 1986 (Article 3 (commencing with Section 2016) of Chapter 3 of Title 3 of Part 4 of the Code of Civil Procedure) shall apply to any proceeding brought under this subdivision consistent with the rules pertaining to judicial arbitration.

3.10.8.3 In addition to Chapter 2.5 (commencing with Section 1141.10) of Title 3 of Part 3 of the Code of Civil Procedure, (A) arbitrators shall, when possible, be experienced in construction law, and (B) any party appealing an arbitration award who does not obtain a more favorable judgment shall, in addition to payment of costs and fees under that chapter, also pay the attorney's fees on appeal of the other party.

3.10.9 Government Code Claims. In addition to any and all contract requirements pertaining to notices of and requests for compensation or payment for extra work, disputed work, claims and/or changed conditions, Contractor must comply with the claim procedures set forth in Government Code sections 900 et seq. prior to filing any lawsuit against the City. Such Government Code claims and any subsequent lawsuit based upon the Government Code claims shall be limited to those matters that remain unresolved after all procedures pertaining to extra work, disputed work, claims, and/or changed conditions have been followed by Contractor. If no such Government Code claim is submitted, or if any prerequisite contractual requirements are not otherwise satisfied as specified herein, Contractor shall be barred from bringing and maintaining a valid lawsuit against the City. A Government Code claim must be filed no earlier than the date the work is completed or the date the Contractor last performs work on the Project, whichever occurs first. A Government Code claim shall be inclusive of all unresolved claims unless a new unrelated claim arises after the Government Code claim is submitted.

3.10.10 Non-Waiver. City's failure to respond to a claim from the Contractor within the time periods described in this Section or to otherwise meet the time requirements of this Section shall result in the claim being deemed rejected in its entirety. City's failure to respond shall not waive City's rights to any subsequent procedures for the resolution of disputed claims.

3.11 Loss and Damage. Except as may otherwise be limited by law, Contractor shall be responsible for all loss and damage which may arise out of the nature of the Work agreed to herein, or from the action of the elements, or from any unforeseen difficulties which may arise or

be encountered in the prosecution of the Work until the same is fully completed and accepted by City. In the event of damage proximately caused by an Act of God, as defined by Section 7105 of the Public Contract Code, the City may terminate this Contract pursuant to Section 3.17.3; provided, however, that the City needs to provide Contractor with only one (1) day advanced written notice.

3.12 Indemnification.

3.12.1 Scope of Indemnity. To the fullest extent permitted by law, Contractor shall defend, indemnify and hold the City, its officials, employees, agents and authorized volunteers free and harmless from any and all claims, demands, causes of action, suits, actions, proceedings, costs, expenses, liability, judgments, awards, decrees, settlements, loss, damage or injury of any kind, in law or equity, to property or persons, including wrongful death, (collectively, "Claims") in any manner arising out of, pertaining to, or incident to any alleged acts, errors or omissions, or willful misconduct of Contractor, its officials, officers, employees, subcontractors, consultants or agents in connection with the performance of the Contractor's services, the Project or this Agreement, including without limitation the payment of all consequential damages, expert witness fees and attorneys' fees and other related costs and expenses. Notwithstanding the foregoing, to the extent required by Civil Code section 2782, Contractor's indemnity obligation shall not apply to liability for damages for death or bodily injury to persons, injury to property, or any other loss, damage or expense arising from the sole or active negligence or willful misconduct of the City or the City's agents, servants, or independent contractors who are directly responsible to the City, or for defects in design furnished by those persons.

3.12.2 Additional Indemnity Obligations. Contractor shall defend, with counsel of City's choosing and at Contractor's own cost, expense and risk, any and all Claims covered by this section that may be brought or instituted against City or its officials, employees, agents and authorized volunteers. In addition, Contractor shall pay and satisfy any judgment, award or decree that may be rendered against City or its officials, employees, agents and authorized volunteers as part of any such claim, suit, action or other proceeding. Contractor shall also reimburse City for the cost of any settlement paid by City or its officials, employees, agents and authorized volunteers as part of any such claim, suit, action or other proceeding. Such reimbursement shall include payment for City's attorney's fees and costs, including expert witness fees. Contractor shall reimburse City and its officials, employees, agents and authorized volunteers, for any and all legal expenses and costs incurred by each of them in connection therewith or in enforcing the indemnity herein provided. Contractor's obligation to indemnify shall not be restricted to insurance proceeds, if any, received by the City, its officials, employees, agents and authorized volunteers.

3.13 Insurance.

3.13.1 Time for Compliance. Contractor shall not commence Work under this Contract until it has provided evidence satisfactory to the City that it has secured all insurance required under this section. In addition, Contractor shall not allow any subcontractor to commence work on any subcontract until it has provided evidence satisfactory to the City that the subcontractor has secured all insurance required under this section. Failure to provide and maintain all required insurance shall be grounds for the City to terminate this Contract for cause.

3.13.2 Minimum Requirements. Contractor shall, at its expense, procure and maintain for the duration of the Contract insurance against claims for injuries to persons or damages to property which may arise from or in connection with the performance of the Work hereunder by Contractor, its agents, representatives, employees or subcontractors. Contractor

shall also require all of its subcontractors to procure and maintain the same insurance for the duration of the Contract. Such insurance shall meet at least the following minimum levels of coverage:

3.13.2.1 Minimum Scope of Insurance. Coverage shall be at least as broad as the latest version of the following: (1) *General Liability*: Insurance Services Office Commercial General Liability coverage (occurrence form CG 00 01) OR Insurance Services Office Owners and Contractors Protective Liability Coverage Form (CG 00 09 11 88) (coverage for operations of designated contractor); (2) *Automobile Liability*: Insurance Services Office Business Auto Coverage form number CA 00 01, code 1 (any auto); and (3) *Workers' Compensation and Employer's Liability*: Workers' Compensation insurance as required by the State of California and Employer's Liability Insurance. Policies shall not contain exclusions contrary to this Contract.

3.13.2.2 Minimum Limits of Insurance. Contractor shall maintain limits no less than: (1) *General Liability*: \$1,000,000 per occurrence and \$1,000,000 aggregate for bodily injury, personal injury and property damage; (2) *Automobile Liability*: \$1,000,000 per accident for bodily injury and property damage; and (3) *Workers' Compensation and Employer's Liability*: Workers' compensation limits as required by the Labor Code of the State of California. Employer's Liability limits of \$1,000,000 each accident, policy limit bodily injury or disease, and each employee bodily injury or disease. Defense costs shall be available in addition to the limits. Notwithstanding the minimum limits specified herein, any available coverage shall be provided to the parties required to be named as additional insureds pursuant to this Contract.

3.13.3 Insurance Endorsements. The insurance policies shall contain the following provisions, or Contractor shall provide endorsements (amendments) on forms supplied or approved by the City to add the following provisions to the insurance policies:

3.13.3.1 General Liability. (1) Such policy shall give the City, its officials, employees, agents and authorized volunteers additional insured status using ISO endorsements CG20 10 10 01 plus CG20 37 10 01, or endorsements providing the exact same coverage, with respect to the Work or operations performed by or on behalf of Contractor, including materials, parts or equipment furnished in connection with such work; (2) all policies shall waive or shall permit Contractor to waive all rights of subrogation which may be obtained by the Contractor or any insurer by virtue of payment of any loss or any coverage provided to any person named as an additional insured pursuant to this Contract, and Contractor agrees to waive all such rights of subrogation; and (3) the insurance coverage shall be primary insurance as respects the City, its officials, employees, agents and authorized volunteers, or if excess, shall stand in an unbroken chain of coverage excess of Contractor's scheduled underlying coverage. Any insurance or self-insurance maintained by the City, its officials, employees, agents and authorized volunteers shall be excess of Contractor's insurance and shall not be called upon to contribute with it.

3.13.3.2 Automobile Liability. (1) Such policy shall give the City, its officials, employees, agents and authorized volunteers additional insured status with respect to the ownership, operation, maintenance, use, loading or unloading of any auto owned, leased, hired or borrowed by Contractor or for which Contractor is responsible; (2) all policies shall waive or shall permit Contractor to waive all rights of subrogation which may be obtained by the Contractor or any insurer by virtue of payment of any loss or any coverage provided to any person named as an additional insured pursuant to this Contract, and Contractor agrees to waive all such rights of subrogation; and (3) the insurance coverage shall be primary insurance as respects the City, its officials, employees, agents and authorized volunteers, or if excess,

shall stand in an unbroken chain of coverage excess of Contractor's scheduled underlying coverage. Any insurance or self-insurance maintained by the City, its officials, employees, agents and authorized volunteers shall be excess of Contractor's insurance and shall not be called upon to contribute with it in any way.

3.13.3.3 Workers' Compensation and Employer's Liability Coverage. The insurer shall agree to waive all rights of subrogation against the City, its officials, employees, agents and authorized volunteers for losses paid under the terms of the insurance policy which arise from work performed by Contractor.

3.13.3.4 All Coverages. Each insurance policy required by this Contract shall be endorsed to state that: (1) coverage shall not be suspended, voided, reduced or canceled except after thirty (30) days prior written notice by certified mail, return receipt requested, has been given to the City; and (2) any failure to comply with reporting or other provisions of the policies, including breaches of warranties, shall not affect coverage provided to the City, its officials, employees, agents and authorized volunteers.

3.13.4 Separation of Insureds; No Special Limitations. All insurance required by this Section shall contain standard separation of insureds provisions. In addition, such insurance shall not contain any special limitations on the scope of protection afforded to the City, its officials, employees, agents and authorized volunteers.

3.13.5 Deductibles and Self-Insurance Retentions. Any deductibles or self-insured retentions must be declared to and approved by the City. Contractor shall guarantee that, at the option of the City, either: (1) the insurer shall reduce or eliminate such deductibles or self-insured retentions as respects the City, its officials, employees, agents and authorized volunteers; or (2) the Contractor shall procure a bond or other financial guarantee acceptable to the City guaranteeing payment of losses and related investigation costs, claims and administrative and defense expenses.

3.13.6 Acceptability of Insurers. Insurance is to be placed with insurers with a current A.M. Best's rating no less than A:VII, licensed to do business in California, and satisfactory to the City. Exception may be made for the State Compensation Insurance Fund when not specifically rated.

3.13.7 Verification of Coverage. Contractor shall furnish City with original certificates of insurance and endorsements effecting coverage required by this Contract on forms satisfactory to the City. The certificates and endorsements for each insurance policy shall be signed by a person authorized by that insurer to bind coverage on its behalf, and shall be on forms supplied or approved by the City. All certificates and endorsements must be received and approved by the City before work commences. The City reserves the right to require complete, certified copies of all required insurance policies, at any time.

3.13.8 Subcontractors. All subcontractors shall meet the requirements of this Section before commencing Work. Contractor shall furnish separate certificates and endorsements for each subcontractor. Subcontractor policies of General Liability insurance shall name the City, its officials, employees, agents and authorized volunteers as additional insureds using form ISO 20 38 04 13 or endorsements providing the exact same coverage. All coverages for subcontractors shall be subject to all of the requirements stated herein except as otherwise agreed to by the City in writing.

3.13.9 Reporting of Claims. Contractor shall report to the City, in addition to Contractor's insurer, any and all insurance claims submitted by Contractor in connection with the Work under this Contract.

3.14 Bond Requirements.

3.14.1 Payment Bond. If required by law or otherwise specifically requested by City in Exhibit "C" attached hereto and incorporated herein by reference, Contractor shall execute and provide to City concurrently with this Contract a Payment Bond in an amount required by the City and in a form provided or approved by the City. If such bond is required, no payment will be made to Contractor until the bond has been received and approved by the City.

3.14.2 Performance Bond. If specifically requested by City in Exhibit "C" attached hereto and incorporated herein by reference, Contractor shall execute and provide to City concurrently with this Contract a Performance Bond in an amount required by the City and in a form provided or approved by the City. If such bond is required, no payment will be made to Contractor until the bond has been received and approved by the City.

3.14.3 Bond Provisions. Should, in City's sole opinion, any bond become insufficient or any surety be found to be unsatisfactory, Contractor shall renew or replace the effected bond within (ten) 10 days of receiving notice from City. In the event the surety or Contractor intends to reduce or cancel any required bond, at least thirty (30) days prior written notice shall be given to the City, and Contractor shall post acceptable replacement bonds at least ten (10) days prior to expiration of the original bonds. No further payments shall be deemed due or will be made under this Contract until any replacement bonds required by this Section are accepted by the City. To the extent, if any, that the Total Contract Price is increased in accordance with the Contract, Contractor shall, upon request of the City, cause the amount of the bond to be increased accordingly and shall promptly deliver satisfactory evidence of such increase to the City. If Contractor fails to furnish any required bond, the City may terminate the Contract for cause.

3.14.4 Surety Qualifications. Only bonds executed by an admitted surety insurer, as defined in California Code of Civil Procedure Section 995.120, shall be accepted. If a California-admitted surety insurer issuing bonds does not meet these requirements, the insurer will be considered qualified if it is in conformance with Section 995.660 of the California Code of Civil Procedure, and proof of such is provided to the City.

3.15 Warranty. Contractor warrants all Work under the Contract (which for purposes of this Section shall be deemed to include unauthorized work which has not been removed and any non-conforming materials incorporated into the Work) to be of good quality and free from any defective or faulty material and workmanship. Contractor agrees that for a period of one year (or the period of time specified elsewhere in the Contract or in any guarantee or warranty provided by any manufacturer or supplier of equipment or materials incorporated into the Work, whichever is later) after the date of final acceptance, Contractor shall within ten (10) days after being notified in writing by the City of any defect in the Work or non-conformance of the Work to the Contract, commence and prosecute with due diligence all Work necessary to fulfill the terms of the warranty at its sole cost and expense. Contractor shall act sooner as requested by the City in response to an emergency. In addition, Contractor shall, at its sole cost and expense, repair and replace any portions of the Work (or work of other contractors) damaged by its defective Work or which becomes damaged in the course of repairing or replacing defective Work. For any Work so corrected, Contractor's obligation hereunder to correct defective Work shall be reinstated for an additional one year period, commencing with the date of acceptance of such corrected Work. Contractor shall perform such tests as the City may require to verify that

any corrective actions, including, without limitation, redesign, repairs, and replacements comply with the requirements of the Contract. All costs associated with such corrective actions and testing, including the removal, replacement, and reinstatement of equipment and materials necessary to gain access, shall be the sole responsibility of Contractor. All warranties and guarantees of subcontractors, suppliers and manufacturers with respect to any portion of the Work, whether express or implied, are deemed to be obtained by Contractor for the benefit of the City, regardless of whether or not such warranties and guarantees have been transferred or assigned to the City by separate agreement and Contractor agrees to enforce such warranties and guarantees, if necessary, on behalf of the City. In the event that Contractor fails to perform its obligations under this Section, or under any other warranty or guaranty under this Contract, to the reasonable satisfaction of the City, the City shall have the right to correct and replace any defective or non-conforming Work and any work damaged by such work or the replacement or correction thereof at Contractor's sole expense. Contractor shall be obligated to fully reimburse the City for any expenses incurred hereunder upon demand.

3.16 Employee/Labor Certifications.

3.16.1 Contractor's Labor Certification. By its signature hereunder, Contractor certifies that he is aware of the provisions of Section 3700 of the California Labor Code which require every employer to be insured against liability for Worker's Compensation or to undertake self-insurance in accordance with the provisions of that Code, and agrees to comply with such provisions before commencing the performance of the Work. A certification form for this purpose, which is attached to this Contract as Exhibit "D" and incorporated herein by reference, shall be executed simultaneously with this Contract.

3.16.2 Equal Opportunity Employment. Contractor represents that it is an equal opportunity employer and that it shall not discriminate against any employee or applicant for employment because of race, religion, color, national origin, ancestry, sex, age or other interests protected by the State or Federal Constitutions. Such non-discrimination shall include, but not be limited to, all activities related to initial employment, upgrading, demotion, transfer, recruitment or recruitment advertising, layoff or termination.

3.16.3 Verification of Employment Eligibility. By executing this Contract, Contractor verifies that it fully complies with all requirements and restrictions of state and federal law respecting the employment of undocumented aliens, including, but not limited to, the Immigration Reform and Control Act of 1986, as may be amended from time to time, and shall require all subcontractors and sub-subcontractors to comply with the same.

3.17 General Provisions.

3.17.1 City's Representative. The City hereby designates the General Manager, or his or her designee, to act as its representative for the performance of this Contract ("City's Representative"). City's Representative shall have the power to act on behalf of the City for all purposes under this Contract. Contractor shall not accept direction or orders from any person other than the City's Representative or his or her designee.

3.17.2 Contractor's Representative. Before starting the Work, Contractor shall submit in writing the name, qualifications and experience of its proposed representative who shall be subject to the review and approval of the City ("Contractor's Representative"). Following approval by the City, Contractor's Representative shall have full authority to represent and act on behalf of Contractor for all purposes under this Contract. Contractor's Representative shall supervise and direct the Work, using his best skill and attention, and shall be responsible for all construction means, methods, techniques, sequences and procedures and

for the satisfactory coordination of all portions of the Work under this Contract. Contractor's Representative shall devote full time to the Project and either he or his designee, who shall be acceptable to the City, shall be present at the Work site at all times that any Work is in progress and at any time that any employee or subcontractor of Contractor is present at the Work site. Arrangements for responsible supervision, acceptable to the City, shall be made for emergency Work which may be required. Should Contractor desire to change its Contractor's Representative, Contractor shall provide the information specified above and obtain the City's written approval.

3.17.3 Termination. This Contract may be terminated by City at any time, either with or without cause, by giving Contractor three (3) days advance written notice. In the event of termination by City for any reason other than the fault of Contractor, City shall pay Contractor for all Work performed up to that time as provided herein. In the event of breach of the Contract by Contractor, City may terminate the Contract immediately without notice, may reduce payment to Contractor in the amount necessary to offset City's resulting damages, and may pursue any other available recourse against Contractor. Contractor may not terminate this Contract except for cause. In the event this Contract is terminated in whole or in part as provided, City may procure, upon such terms and in such manner as it may determine appropriate, services similar to those terminated. Further, if this Contract is terminated as provided, City may require Contractor to provide all finished or unfinished documents, data, diagrams, drawings, materials or other matter prepared or built by Contractor in connection with its performance of this Contract.

3.17.4 Contract Interpretation. Should any question arise regarding the meaning or import of any of the provisions of this Contract or written or oral instructions from City, the matter shall be referred to City's Representative, whose decision shall be binding upon Contractor.

3.17.5 Anti-Trust Claims. This provision shall be operative if this Contract is applicable to California Public Contract Code Section 7103.5. In entering into this Contract to supply goods, services or materials, Contractor hereby offers and agrees to assign to the City all rights, title, and interest in and to all causes of action it may have under Section 4 of the Clayton Act (15 U.S.C. Section 15) or under the Cartwright Act (Chapter 2, commencing with Section 16700, of Part 2 of Division 7 of the Business and Professions Code) arising from purchases of goods, services, or materials pursuant to the Contract. This assignment shall be made and become effective at the time the City tender final payment to Contractor, without further acknowledgment by the Parties.

3.17.6 Notices. All notices hereunder and communications regarding interpretation of the terms of the Contract or changes thereto shall be provided by the mailing thereof by registered or certified mail, return receipt requested, postage prepaid and addressed as follows:

CONTRACTOR:

Carrier Corporation
2478 Peck Road
City of Industry, CA 90601
Attn: Dan Marquez

CITY:

City of Arcadia
240 West Huntington Drive
Arcadia, California 91066
Attn: Carlos Aguilar, General Services Superintendent

Any notice so given shall be considered received by the other Party three (3) days after deposit in the U.S. Mail as stated above and addressed to the Party at the above address. Actual notice shall be deemed adequate notice on the date actual notice occurred, regardless of the method of service.

3.17.7 Time of Essence. Time is of the essence in the performance of this Contract.

3.17.8 Assignment Forbidden. Contractor shall not, either voluntarily or by action of law, assign or transfer this Contract or any obligation, right, title or interest assumed by Contractor herein without the prior written consent of City. If Contractor attempts an assignment or transfer of this Contract or any obligation, right, title or interest herein, City may, at its option, terminate and revoke the Contract and shall thereupon be relieved from any and all obligations to Contractor or its assignee or transferee.

3.17.9 No Third Party Beneficiaries. There are no intended third party beneficiaries of any right or obligation assumed by the Parties.

3.17.10 Laws, Venue, and Attorneys' Fees. This Agreement shall be interpreted in accordance with the laws of the State of California. If any action is brought to interpret or enforce any term of this Agreement, the action shall be brought in a state or federal court situated in the County of Los Angeles, State of California.

3.17.11 Counterparts. This Contract may be executed in counterparts, each of which shall constitute an original.

3.17.12 Successors. The Parties do for themselves, their heirs, executors, administrators, successors, and assigns agree to the full performance of all of the provisions contained in this Contract.

3.17.13 [Reserved]

3.17.14 Solicitation. Contractor maintains and warrants that it has not employed nor retained any company or person, other than a bona fide employee working solely for Contractor, to solicit or secure this Contract. Further, Contractor warrants that it has not paid nor has it agreed to pay any company or person, other than a bona fide employee working solely for Contractor, any fee, commission, percentage, brokerage fee, gift or other consideration contingent upon or resulting from the award or making of this Contract. For breach or violation of this warranty, City shall have the right to terminate this Contract without liability.

3.17.15 Conflict of Interest. Contractor maintains and warrants that it has not employed nor retained any company or person, other than a bona fide employee working solely for Contractor, to solicit or secure this Agreement. Further, Contractor warrants that it has not paid nor has it agreed to pay any company or person, other than a bona fide employee working solely for Contractor, any fee, commission, percentage, brokerage fee, gift or other consideration contingent upon or resulting from the award or making of this Agreement. For

breach or violation of this warranty, City shall have the right to rescind this Agreement without liability. For the term of this Contract, no official, officer or employee of City, during the term of his or her service with City, shall have any direct interest in this Contract, or obtain any present or anticipated material benefit arising therefrom. In addition, Contractor agrees to file, or to cause its employees or subcontractors to file, a Statement of Economic Interest with the City's Filing Officer as required under state law in the performance of the Work.

3.17.16 Certification of License.

3.17.16.1 Contractor certifies that as of the date of execution of this Contract, Contractor has a current contractor's license of the classification indicated below under Contractor's signature.

3.17.16.2 Contractors are required by law to be licensed and regulated by the Contractors' State License Board which has jurisdiction to investigate complaints against contractors if a complaint regarding a patent act or omission is filed within four (4) years of the date of the alleged violation. A complaint regarding a latent act or omission pertaining to structural defects must be filed within ten (10) years of the date of the alleged violation. Any questions concerning a contractor may be referred to the Registrar, Contractors' State License Board, P.O. Box 26000, Sacramento, California 95826.

3.17.17 Authority to Enter Contract. Each Party warrants that the individuals who have signed this Contract have the legal power, right and authority to make this Contract and bind each respective Party.

3.17.18 Entire Contract; Modification. This Contract contains the entire agreement of the Parties with respect to the subject matter hereof, and supersedes all prior negotiations, understandings or agreements. This Contract may only be modified by a writing signed by both Parties.

3.17.19 Non-Waiver. None of the provisions of this Agreement shall be considered waived by either party, unless such waiver is specifically specified in writing.

3.17.20 City's Right to Employ Other Contractors. City reserves right to employ other contractors in connection with this Project or other projects.

[SIGNATURES ON NEXT PAGE]

**SIGNATURE PAGE FOR CONSTRUCTION CONTRACT
BETWEEN THE CITY OF ARCADIA
AND CARRIER CORPORATION**

IN WITNESS WHEREOF, the Parties have entered into this Agreement as of the _____ day of _____, 2024.

CITY OF ARCADIA

CARRIER CORPORATION

By: _____
Dominic Lazaretto
City Manager

By: _____
Its: _____

Printed Name: _____

ATTEST:

By: _____

By: _____
City Clerk

Its: _____

Printed Name: _____

APPROVED AS TO FORM:

By: _____
Michael J. Maurer
City Attorney

EXHIBIT "A"

SERVICES / SCHEDULE

The project plan and proposal, Carrier Corporation Quote Number 00810866, are incorporation into this Contract. Services shall include but not limited to the following:

Scope of Work

- Disconnect electrical, controls, drain and gas lines
- Furnish and replace five (5) A/C units with new Carrier equipment (same capacity and voltage as existing)
- Note 1: A/C Equipment submittals provided on separate attachment
- Reconnect to existing electrical with new service disconnect and seal tight
- Reconnect existing controls (by customer's controls company)
- Reconnect to existing drain and gas lines
- Perform Factory Start-up to verify operation and clean work area
- Note 2: Crane fees included
- Note 3: Carrier to have old equipment hauled away and properly disposed of

EXHIBIT "B"

PLANS AND SPECIFICATIONS

All service and unit specifications are listed in Exhibit "A".

EXHIBIT "C"

SPECIAL CONDITIONS

ARTICLE 1. BONDS

Within ten (10) calendar days from the date the Contractor is notified of award of the Contract, the Contractor shall deliver to the City four identical counterparts of the Performance Bond and Payment Bond on the forms supplied by the City and included as Exhibit "F" to the Contract. Failure to do so may, in the sole discretion of City, result in the forfeiture of Contractor's bid security. The surety supplying the bond must be an admitted surety insurer, as defined in Code of Civil Procedure Section 995.120, authorized to do business as such in the State of California and satisfactory to the City. The Performance Bond and the Payment Bond shall be for one hundred percent (100%) of the Total Contract Price.

EXHIBIT "D"

**CERTIFICATION
LABOR CODE - SECTION 1861**

I, the undersigned Contractor, am aware of the provisions of Section 3700, et seq., of the California Labor Code which require every employer to be insured against liability for Worker's Compensation or to undertake self-insurance in accordance with the provisions of the Code, and I, the undersigned Contractor, agree to and will comply with such provisions before commencing the performance of the Work on this Contract.

CARRIER CORPORATION

By: _____
Signature

Name (Print)

Title (Print)

EXHIBIT “E”

PUBLIC WORKS CONTRACTOR REGISTRATION CERTIFICATION

Pursuant to Labor Code sections 1725.5 and 1771.1, all contractors and subcontractors that wish to bid on, be listed in a bid proposal, or enter into a contract to perform public work must be registered with the Department of Industrial Relations. See <http://www.dir.ca.gov/Public-Works/PublicWorks.html> for additional information.

No bid will be accepted nor any contract entered into without proof of the contractor’s and subcontractors’ current registration with the Department of Industrial Relations to perform public work.

Contractor hereby certifies that it is aware of the registration requirements set forth in Labor Code sections 1725.5 and 1771.1 and is currently registered as a contractor with the Department of Industrial Relations.¹

Name of Contractor: _____

DIR Registration Number: _____

DIR Registration Expiration: _____

Small Project Exemption: _____ Yes or _____ No

Unless Contractor is exempt pursuant to the small project exemption, Contractor further acknowledges:

- Contractor shall maintain a current DIR registration for the duration of the project.
- Contractor shall include the requirements of Labor Code sections 1725.5 and 1771.1 in its contract with subcontractors and ensure that all subcontractors are registered at the time of bid opening and maintain registration status for the duration of the project.
- Failure to submit this form or comply with any of the above requirements may result in a finding that the bid is non-responsive.

Name of Contractor _____

Signature _____

Name and Title _____

Dated _____

¹ If the Project is exempt from the contractor registration requirements pursuant to the small project exemption under Labor Code Sections 1725.5 and 1771.1, please mark “Yes” in response to “Small Project Exemption.”

EXHIBIT "F"
PAYMENT AND PERFORMANCE BONDS

PERFORMANCE BOND

KNOW ALL PERSONS BY THESE PRESENTS:

THAT WHEREAS, the City of Arcadia (hereinafter referred to as "City") has awarded to **Carrier Corporation**, (hereinafter referred to as the "Contractor") an agreement for **Library HVAC Units Replacement Project** (hereinafter referred to as the "Project").

WHEREAS, the work to be performed by the Contractor is more particularly set forth in the Contract Documents for the Project dated _____, (hereinafter referred to as "Contract Documents"), the terms and conditions of which are expressly incorporated herein by reference; and

WHEREAS, the Contractor is required by said Contract Documents to perform the terms thereof and to furnish a bond for the faithful performance of said Contract Documents.

NOW, THEREFORE, we, _____, the undersigned Contractor and _____ as Surety, a corporation organized and duly authorized to transact business under the laws of the State of California, are held and firmly bound unto the City in the sum of **ONE HUNDRED FORTY THOUSAND, FOUR HUNDRED SIXTY-NINE DOLLARS AND NO CENTS (\$140,469.00)**, said sum being not less than one hundred percent (100%) of the total amount of the Contract, for which amount well and truly to be made, we bind ourselves, our heirs, executors and administrators, successors and assigns, jointly and severally, firmly by these presents.

THE CONDITION OF THIS OBLIGATION IS SUCH, that, if the Contractor, his or its heirs, executors, administrators, successors or assigns, shall in all things stand to and abide by, and well and truly keep and perform the covenants, conditions and agreements in the Contract Documents and any alteration thereof made as therein provided, on its part, to be kept and performed at the time and in the manner therein specified, and in all respects according to their intent and meaning; and shall faithfully fulfill all obligations including the one-year guarantee of all materials and workmanship; and shall indemnify and save harmless the City, its officers and agents, as stipulated in said Contract Documents, then this obligation shall become null and void; otherwise it shall be and remain in full force and effect.

As a condition precedent to the satisfactory completion of the Contract Documents, unless otherwise provided for in the Contract Documents, the above obligation shall hold good for a period of one (1) year after the acceptance of the work by City, during which time if Contractor shall fail to make full, complete, and satisfactory repair and replacements and totally protect the City from loss or damage resulting from or caused by defective materials or faulty workmanship, Surety shall undertake and faithfully fulfill all such obligations. The obligations of Surety hereunder shall continue so long as any obligation of Contractor remains. Nothing herein shall limit the City's rights or the Contractor or Surety's obligations under the Contract, law or equity, including, but not limited to, California Code of Civil Procedure section 337.15.

Whenever Contractor shall be, and is declared by the City to be, in default under the Contract Documents, the Surety shall remedy the default pursuant to the Contract Documents, or shall promptly, at the City's option:

- (1) Take over and complete the Project in accordance with all terms and conditions in the Contract Documents; or

- (2) Obtain a bid or bids for completing the Project in accordance with all terms and conditions in the Contract Documents and upon determination by Surety of the lowest responsive and responsible bidder, arrange for a Contract between such bidder, the Surety and the City, and make available as work progresses sufficient funds to pay the cost of completion of the Project, less the balance of the contract price, including other costs and damages for which Surety may be liable. The term "balance of the contract price" as used in this paragraph shall mean the total amount payable to Contractor by the City under the Contract and any modification thereto, less any amount previously paid by the City to the Contractor and any other set offs pursuant to the Contract Documents.
- (3) Permit the City to complete the Project in any manner consistent with local, California and federal law and make available as work progresses sufficient funds to pay the cost of completion of the Project, less the balance of the contract price, including other costs and damages for which Surety may be liable. The term "balance of the contract price" as used in this paragraph shall mean the total amount payable to Contractor by the City under the Contract and any modification thereto, less any amount previously paid by the City to the Contractor and any other set offs pursuant to the Contract Documents.

Surety expressly agrees that the City may reject any contractor or subcontractor which may be proposed by Surety in fulfillment of its obligations in the event of default by the Contractor.

Surety shall not utilize Contractor in completing the Project nor shall Surety accept a bid from Contractor for completion of the Project if the City, when declaring the Contractor in default, notifies Surety of the City's objection to Contractor's further participation in the completion of the Project.

The Surety, for value received, hereby stipulates and agrees that no change, extension of time, alteration or addition to the terms of the Contract Documents or to the Project to be performed thereunder shall in any way affect its obligations on this bond, and it does hereby waive notice of any such change, extension of time, alteration or addition to the terms of the Contract Documents or to the Project, including but not limited to the provisions of sections 2819 and 2845 of the California Civil Code.

IN WITNESS WHEREOF, we have hereunto set our hands and seals this _____ day of _____, 20__).

(Corporate Seal)

Contractor/ Principal

By _____

Title _____

(Corporate Seal)

Surety

By _____
Attorney-in-Fact

Signatures of those signing for the Contractor and Surety must be notarized and evidence of corporate authority attached.

(Attach Attorney-in-Fact Certificate) Title _____

The rate of premium on this bond is _____ per thousand. The total amount of premium charges, \$_____.
(The above must be filled in by corporate attorney.)

THIS IS A REQUIRED FORM

Any claims under this bond may be addressed to:

(Name and Address of Surety) _____

(Name and Address of Agent or Representative for service of process in California, if different from above) _____

(Telephone number of Surety and Agent or Representative for service of process in California) _____

NOTE: A copy of the Power-of-Attorney authorizing the person signing on behalf of the Surety to do so must be attached hereto.

Notary Acknowledgment

A notary public or other officer completing this certificate verifies only the identity of the individual who signed the document to which this certificate is attached, and not the truthfulness, accuracy, or validity of that document.

STATE OF CALIFORNIA
 COUNTY OF _____

On _____, 20____, before me, _____, Notary Public, personally appeared _____, who proved to me on the basis of satisfactory

evidence to be the person(s) whose name(s) is/are subscribed to the within instrument and acknowledged to me that he/she/they executed the same in his/her/their authorized capacity(ies), and that by his/her/their signature(s) on the instrument the person(s), or the entity upon behalf of which the person(s) acted, executed the instrument.

I certify under PENALTY OF PERJURY under the laws of the State of California that the foregoing paragraph is true and correct.

WITNESS my hand and official seal.

Signature of Notary Public _____

OPTIONAL

Though the information below is not required by law, it may prove valuable to persons relying on the document and could prevent fraudulent removal and reattachment of this form to another document.

CAPACITY CLAIMED BY SIGNER

- Individual
- Corporate Officer

_____ Title(s)

- Partner(s) Limited
- General

- Attorney-In-Fact
- Trustee(s)
- Guardian/Conservator
- Other:

Signer is representing:
 Name Of Person(s) Or Entity(ies)

DESCRIPTION OF ATTACHED DOCUMENT

_____ Title or Type of Document

_____ Number of Pages

_____ Date of Document

_____ Signer(s) Other Than Named Above

PAYMENT BOND

KNOW ALL MEN BY THESE PRESENTS That

WHEREAS, the City of Arcadia (hereinafter designated as the "City"), by action taken or a resolution passed **May 7, 2024** has awarded to **Carrier Corporation** hereinafter designated as the "Principal," a contract for the work described as follows:

Library HVAC Units Replacement Project (the "Project"); and

WHEREAS, the work to be performed by the Principal is more particularly set forth in the Contract Documents for the Project dated _____ ("Contract Documents"), the terms and conditions of which are expressly incorporated by reference; and

WHEREAS, said Principal is required to furnish a bond in connection with said contract; providing that if said Principal or any of its Subcontractors shall fail to pay for any materials, provisions, provender, equipment, or other supplies used in, upon, for or about the performance of the work contracted to be done, or for any work or labor done thereon of any kind, or for amounts due under the Unemployment Insurance Code or for any amounts required to be deducted, withheld, and paid over to the Employment Development Department from the wages of employees of said Principal and its Subcontractors with respect to such work or labor the Surety on this bond will pay for the same to the extent hereinafter set forth.

NOW THEREFORE, we, the Principal and _____ as Surety, are held and firmly bound unto the City in the penal sum of **ONE HUNDRED FORTY THOUSAND, FOUR HUNDRED SIXTY-NINE DOLLARS AND NO CENTS (\$140,469.00)** lawful money of the United States of America, for the payment of which sum well and truly to be made, we bind ourselves, our heirs, executors, administrators, successors and assigns, jointly and severally, firmly by these presents.

THE CONDITION OF THIS OBLIGATION IS SUCH that if said Principal, his or its subcontractors, heirs, executors, administrators, successors or assigns, shall fail to pay any of the persons named in Section 9100 of the Civil Code, fail to pay for any materials, provisions or other supplies, used in, upon, for or about the performance of the work contracted to be done, or for any work or labor thereon of any kind, or amounts due under the Unemployment Insurance Code with respect to work or labor performed under the contract, or for any amounts required to be deducted, withheld, and paid over to the Employment Development Department or Franchise Tax Board from the wages of employees of the contractor and his subcontractors pursuant to Section 18663 of the Revenue and Taxation Code, with respect to such work and labor the Surety or Sureties will pay for the same, in an amount not exceeding the sum herein above specified.

This bond shall inure to the benefit of any of the persons named in Section 9100 of the Civil Code so as to give a right of action to such persons or their assigns in any suit brought upon this bond.

It is further stipulated and agreed that the Surety on this bond shall not be exonerated or released from the obligation of this bond by any change, extension of time for performance, addition, alteration or modification in, to, or of any contract, plans, specifications, or agreement pertaining or relating to any scheme or work of improvement herein above described, or pertaining or relating to the furnishing of labor, materials, or equipment therefore, nor by any change or modification of any terms of payment or extension of the time for any payment pertaining or relating to any scheme or work of improvement herein above described, nor by any

rescission or attempted rescission of the contract, agreement or bond, nor by any conditions precedent or subsequent in the bond attempting to limit the right of recovery of claimants otherwise entitled to recover under any such contract or agreement or under the bond, nor by any fraud practiced by any person other than the claimant seeking to recover on the bond and that this bond be construed most strongly against the Surety and in favor of all persons for whose benefit such bond is given, and under no circumstances shall Surety be released from liability to those for whose benefit such bond has been given, by reason of any breach of contract between the owner or City and original contractor or on the part of any obligee named in such bond, but the sole conditions of recovery shall be that claimant is a person described in Section 9100 of the Civil Code, and has not been paid the full amount of his claim and that Surety does hereby waive notice of any such change, extension of time, addition, alteration or modification herein mentioned and the provisions of sections 2819 and 2845 of the California Civil Code.

IN WITNESS WHEREOF, we have hereunto set our hands and seals this _____ day of _____, 20__.

(Corporate Seal)

Contractor/ Principal

By _____

Title _____

(Corporate Seal)

Surety

By _____
Attorney-in-Fact

Title _____

Signatures of those signing for the Contractor and Surety must be notarized and evidence of corporate authority attached. A Power-of-Attorney authorizing the person signing on behalf of the Surety to do so must be attached hereto.

NOTE: A copy of the Power-of-Attorney authorizing the person signing on behalf of the Surety to do so must be attached hereto.

Notary Acknowledgment

A notary public or other officer completing this certificate verifies only the identity of the individual who signed the document to which this certificate is attached, and not the truthfulness, accuracy, or validity of that document.

STATE OF CALIFORNIA
 COUNTY OF _____

On _____, 20____, before me, _____, Notary Public, personally appeared _____, who proved to me on the basis of satisfactory

evidence to be the person(s) whose name(s) is/are subscribed to the within instrument and acknowledged to me that he/she/they executed the same in his/her/their authorized capacity(ies), and that by his/her/their signature(s) on the instrument the person(s), or the entity upon behalf of which the person(s) acted, executed the instrument.

I certify under PENALTY OF PERJURY under the laws of the State of California that the foregoing paragraph is true and correct.

WITNESS my hand and official seal.

Signature of Notary Public _____

OPTIONAL

Though the information below is not required by law, it may prove valuable to persons relying on the document and could prevent fraudulent removal and reattachment of this form to another document.

CAPACITY CLAIMED BY SIGNER

- Individual
- Corporate Officer

_____ Title(s)

- Partner(s) Limited
- General
- Attorney-In-Fact
- Trustee(s)
- Guardian/Conservator
- Other:

Signer is representing:
 Name Of Person(s) Or Entity(ies)

DESCRIPTION OF ATTACHED DOCUMENT

_____ Title or Type of Document

_____ Number of Pages

_____ Date of Document

_____ Signer(s) Other Than Named Above

EXHIBIT "G"
FEDERAL REQUIREMENTS

NOT APPLICABLE.



STAFF REPORT

Fire Department

DATE: May 7, 2024
TO: Honorable Mayor and City Council
FROM: Chen Suen, Fire Chief
By: Cody Cerwin, Deputy Fire Chief
Maria Lourdes Taylor, Sr. Management Analyst

SUBJECT: CONTRACT WITH LEXIPOL TO PROVIDE POLICY IMPLEMENTATION AND MANAGEMENT SERVICES FOR THE FIRE DEPARTMENT IN THE AMOUNT OF \$40,221 AND AN ANNUAL SUBSCRIPTION COST OF \$12,192
CEQA: Not a Project
Recommendation: Approve

SUMMARY

Personnel and Administrative Policies provide the foundation and guidance for all operations of the Arcadia Fire Department. Therefore, it is vital to be consistent with ever-changing legislative updates and case law to help reduce risk and liability. Maintaining and updating these policies has been completed in-house over the years; however, it has since been determined that contracting with Lexipol, a leader in policy management services, is the more feasible and effective alternative to ensure timely updates. Lexipol has been utilized by the Police Department for many years and has proven to be a valuable partner in maintaining highly-important policies. Lexipol was selected by utilizing Sourcewell, a national cooperative purchasing program, enabling the City to streamline the procurement process and obtain the most competitive price possible (see attachments for Sourcewell contract and Lexipol's bid pricing). The contract expires on March 23, 2026, with an option to extend it for one additional year.

The initial contract payment of \$17,077 will be paid during FY 2023-24, with the remaining contract balance and the annual subscription payments to be paid during the subsequent fiscal years, as part of the Citywide annual budget process. It is recommended that the City Council approve, authorize, and direct the City Manager to execute the contract with Lexipol to provide policy implementation and management services for the Fire Department, in the amount of \$40,221 plus an annual subscription cost of \$12,192.

DISCUSSION

Historically, the Fire Department's 180 operational policies have been produced in-house by the Fire Chief, due to the significance and compulsory nature of their content. While

this approach has worked fairly well, this process has become increasingly challenging and impractical to sustain as new legislation and case law have changed more frequently. Missing important legislation or case law updates that could affect training policies and procedures poses a significant risk to the organization.

For the past two years, staff has been researching reasonable alternatives to address this issue and concluded that outsourcing policy implementation and management services would be the most sustainable choice. The Fire Department has opted to utilize Lexipol for this service, an industry leader in policy development and maintenance, which also offers a comprehensive policy implementation and management tool.

Lexipol is a subscription-based online learning and policy training system that provides baseline policies that are vetted by legal experts and includes best practices. These policies can be revised so they are adaptable for individual agencies. Lexipol also sends continuous updates as case law and legal requirements change, allowing the Fire Department to alter its policies quickly and administer new training to Fire personnel. Essentially, their service would be customized to fit the Fire Department's specific policy needs and includes scenario-based daily training bulletins with personnel tests to reinforce and prove policy comprehension. The system would be accessible online and through mobile devices, provide real-time updates as well as a supplemental manual that integrates the Department's procedural content into sections of the policy manual.

Lexipol has been in business for 19 years and is the industry-leader in providing policy, procedure, and online training for public safety. The expertise of Lexipol is demonstrated through their comprehensive, state-specific public safety policy manuals backed by daily training, to reinforce policy understanding and use. Presently, Lexipol serves more than 800 public safety and local government organizations nationwide. With Lexipol's long-standing credentials, they are more than capable of supplying high-quality policy implementation and management services specific to the Arcadia Fire Department.

The Police Department has successfully utilized Lexipol for many years, and as a result, the number of claims against the City and incidents involving policy violations has decreased. Lexipol has been an effective training tool as well as a strong legal defense, with the policies being updated regularly and fast-tracked to all staff.

Lexipol's total contract amount is \$40,221, which includes the initial subscription set-up (\$17,077) and the system's full implementation (\$23,144). Following initial implementation, there is an annual subscription fee of \$12,192. The annual subscription fee is to ensure that policy updates and best practices are implemented and maintained. After exploring possible purchasing options, piggybacking through Sourcewell, a national cooperative purchasing program, allows the City to streamline the procurement process and receive the best price possible. The contract expires March 23, 2026, with an option to extend for one additional year.

Cognizant of the Fire Department's current Operating Budget limitation, Lexipol is willing to extend its contract payment term for two Fiscal Years (FY 2023-24 through FY 2024-

25), with an annual subscription fee thereafter. After the current mid-year budget review, the Fire Department realized some savings from its Contract Services account that is best utilized to partially fund Lexipol's implementation cost of \$17,077. The remaining balance of the \$23,144 will be paid from the proposed FY 2024-25 Fire Operating Budget, and the annual subscription of \$12,192 will be budgeted in the subsequent fiscal years. To cover the contract cost for FY 2024-25 and thereafter, funding would be proposed as part of the Citywide annual budget adoption.

Based on the foregoing, it is recommended that the City enter into an agreement with Lexipol for policy development and maintenance services for the Fire Department.

ENVIRONMENTAL ANALYSIS

The proposed action does not constitute a project under the California Environmental Quality Act ("CEQA"), as it can be seen with certainty that it will have no impact on the environment.

FISCAL IMPACT

Lexipol's total contract amount to provide policy implementation and management services for the Fire Department is \$40,221. A portion of this total cost, in the amount of \$17,077, is available in the current FY2023-24 Fire Operating Budget. The remaining balance of \$23,144 would be paid from the proposed FY 2024-25 Fire Operating Budget, and the annual subscription cost of \$12,192 from the subsequent fiscal year budgets.

RECOMMENDATION

It is recommended that the City Council determine that this action does not constitute a project under the California Environmental Quality Act ("CEQA"); and approve, authorize, and direct the City Manager to execute the contract with Lexipol to provide policy implementation and management services for the Fire Department in the amount of \$40,221 and an annual subscription cost of \$12,192.

Approved:

Dominic Lazzaretto
City Manager

Attachments: Sourcewell Contract #011822
Lexipol Master Service Agreement



Solicitation Number: RFP #011822

CONTRACT

This Contract is between Sourcewell, 202 12th Street Northeast, P.O. Box 219, Staples, MN 56479 (Sourcewell) and Lexipol, LLC, 2611 Internet Blvd., Suite 100, Frisco, TX 75034 (Supplier).

Sourcewell is a State of Minnesota local government unit and service cooperative created under the laws of the State of Minnesota (Minnesota Statutes Section 123A.21) that offers cooperative procurement solutions to government entities. Participation is open to eligible federal, state/province, and municipal governmental entities, higher education, K-12 education, nonprofit, tribal government, and other public entities located in the United States and Canada. Sourcewell issued a public solicitation for Public Safety Training and Simulation Equipment and Technology from which Supplier was awarded a contract.

Supplier desires to contract with Sourcewell to provide equipment, products, or services to Sourcewell and the entities that access Sourcewell's cooperative purchasing contracts (Participating Entities).

1. TERM OF CONTRACT

- A. **EFFECTIVE DATE.** This Contract is effective upon the date of the final signature below.
- B. **EXPIRATION DATE AND EXTENSION.** This Contract expires March 23, 2026, unless it is cancelled sooner pursuant to Article 22. This Contract may be extended one additional year upon the request of Sourcewell and written agreement by Supplier.
- C. **SURVIVAL OF TERMS.** Notwithstanding any expiration or termination of this Contract, all payment obligations incurred prior to expiration or termination will survive, as will the following: Articles 11 through 14 survive the expiration or cancellation of this Contract. All other rights will cease upon expiration or termination of this Contract.

2. EQUIPMENT, PRODUCTS, OR SERVICES

- A. **EQUIPMENT, PRODUCTS, OR SERVICES.** Supplier will provide the Equipment, Products, or Services as stated in its Proposal submitted under the Solicitation Number listed above. Supplier's Equipment, Products, or Services Proposal (Proposal) is attached and incorporated into this Contract.

All Equipment and Products provided under this Contract must be new and the current model. Supplier may offer close-out or refurbished Equipment or Products if they are clearly indicated in Supplier's product and pricing list. Unless agreed to by the Participating Entities in advance, Equipment or Products must be delivered as operational to the Participating Entity's site.

This Contract offers an indefinite quantity of sales, and while substantial volume is anticipated, sales and sales volume are not guaranteed.

B. **WARRANTY.** Supplier warrants that all Equipment, Products, and Services furnished are free from liens and encumbrances, and are free from defects in design, materials, and workmanship. In addition, Supplier warrants the Equipment, Products, and Services are suitable for and will perform in accordance with the ordinary use for which they are intended. Supplier's dealers and distributors must agree to assist the Participating Entity in reaching a resolution in any dispute over warranty terms with the manufacturer. Any manufacturer's warranty that extends beyond the expiration of the Supplier's warranty will be passed on to the Participating Entity.

C. **DEALERS, DISTRIBUTORS, AND/OR RESELLERS.** Upon Contract execution and throughout the Contract term, Supplier must provide to Sourcewell a current means to validate or authenticate Supplier's authorized dealers, distributors, or resellers relative to the Equipment, Products, and Services offered under this Contract, which will be incorporated into this Contract by reference. It is the Supplier's responsibility to ensure Sourcewell receives the most current information.

3. PRICING

All Equipment, Products, or Services under this Contract will be priced at or below the price stated in Supplier's Proposal.

When providing pricing quotes to Participating Entities, all pricing quoted must reflect a Participating Entity's total cost of acquisition. This means that the quoted cost is for delivered Equipment, Products, and Services that are operational for their intended purpose, and includes all costs to the Participating Entity's requested delivery location.

Regardless of the payment method chosen by the Participating Entity, the total cost associated with any purchase option of the Equipment, Products, or Services must always be disclosed in the pricing quote to the applicable Participating Entity at the time of purchase.

A. **SHIPPING AND SHIPPING COSTS.** All delivered Equipment and Products must be properly packaged. Damaged Equipment and Products may be rejected. If the damage is not readily apparent at the time of delivery, Supplier must permit the Equipment and Products to be returned within a reasonable time at no cost to Sourcewell or its Participating Entities. Participating Entities reserve the right to inspect the Equipment and Products at a reasonable

time after delivery where circumstances or conditions prevent effective inspection of the Equipment and Products at the time of delivery. In the event of the delivery of nonconforming Equipment and Products, the Participating Entity will notify the Supplier as soon as possible and the Supplier will replace nonconforming Equipment and Products with conforming Equipment and Products that are acceptable to the Participating Entity.

Supplier must arrange for and pay for the return shipment on Equipment and Products that arrive in a defective or inoperable condition.

Sourcwell may declare the Supplier in breach of this Contract if the Supplier intentionally delivers substandard or inferior Equipment or Products.

B. SALES TAX. Each Participating Entity is responsible for supplying the Supplier with valid tax-exemption certification(s). When ordering, a Participating Entity must indicate if it is a tax-exempt entity.

C. HOT LIST PRICING. At any time during this Contract, Supplier may offer a specific selection of Equipment, Products, or Services at discounts greater than those listed in the Contract. When Supplier determines it will offer Hot List Pricing, it must be submitted electronically to Sourcwell in a line-item format. Equipment, Products, or Services may be added or removed from the Hot List at any time through a Sourcwell Price and Product Change Form as defined in Article 4 below.

Hot List program and pricing may also be used to discount and liquidate close-out and discontinued Equipment and Products as long as those close-out and discontinued items are clearly identified as such. Current ordering process and administrative fees apply. Hot List Pricing must be published and made available to all Participating Entities.

4. PRODUCT AND PRICING CHANGE REQUESTS

Supplier may request Equipment, Product, or Service changes, additions, or deletions at any time. All requests must be made in writing by submitting a signed Sourcwell Price and Product Change Request Form to the assigned Sourcwell Supplier Development Administrator. This approved form is available from the assigned Sourcwell Supplier Development Administrator. At a minimum, the request must:

- Identify the applicable Sourcwell contract number;
- Clearly specify the requested change;
- Provide sufficient detail to justify the requested change;
- Individually list all Equipment, Products, or Services affected by the requested change, along with the requested change (e.g., addition, deletion, price change); and

- Include a complete restatement of pricing documentation in Microsoft Excel with the effective date of the modified pricing, or product addition or deletion. The new pricing restatement must include all Equipment, Products, and Services offered, even for those items where pricing remains unchanged.

A fully executed Sourcewell Price and Product Change Request Form will become an amendment to this Contract and will be incorporated by reference.

5. PARTICIPATION, CONTRACT ACCESS, AND PARTICIPATING ENTITY REQUIREMENTS

A. PARTICIPATION. Sourcewell's cooperative contracts are available and open to public and nonprofit entities across the United States and Canada; such as federal, state/province, municipal, K-12 and higher education, tribal government, and other public entities.

The benefits of this Contract should be available to all Participating Entities that can legally access the Equipment, Products, or Services under this Contract. A Participating Entity's authority to access this Contract is determined through its cooperative purchasing, interlocal, or joint powers laws. Any entity accessing benefits of this Contract will be considered a Service Member of Sourcewell during such time of access. Supplier understands that a Participating Entity's use of this Contract is at the Participating Entity's sole convenience and Participating Entities reserve the right to obtain like Equipment, Products, or Services from any other source.

Supplier is responsible for familiarizing its sales and service forces with Sourcewell contract use eligibility requirements and documentation and will encourage potential participating entities to join Sourcewell. Sourcewell reserves the right to add and remove Participating Entities to its roster during the term of this Contract.

B. PUBLIC FACILITIES. Supplier's employees may be required to perform work at government-owned facilities, including schools. Supplier's employees and agents must conduct themselves in a professional manner while on the premises, and in accordance with Participating Entity policies and procedures, and all applicable laws.

6. PARTICIPATING ENTITY USE AND PURCHASING

A. ORDERS AND PAYMENT. To access the contracted Equipment, Products, or Services under this Contract, a Participating Entity must clearly indicate to Supplier that it intends to access this Contract; however, order flow and procedure will be developed jointly between Sourcewell and Supplier. Typically, a Participating Entity will issue an order directly to Supplier or its authorized subsidiary, distributor, dealer, or reseller. If a Participating Entity issues a purchase order, it may use its own forms, but the purchase order should clearly note the applicable Sourcewell contract number. All Participating Entity orders under this Contract must be issued prior to expiration or cancellation of this Contract; however, Supplier performance, Participating Entity

payment obligations, and any applicable warranty periods or other Supplier or Participating Entity obligations may extend beyond the term of this Contract.

Supplier's acceptable forms of payment are included in its attached Proposal. Participating Entities will be solely responsible for payment and Sourcewell will have no liability for any unpaid invoice of any Participating Entity.

B. ADDITIONAL TERMS AND CONDITIONS/PARTICIPATING ADDENDUM. Additional terms and conditions to a purchase order, or other required transaction documentation, may be negotiated between a Participating Entity and Supplier, such as job or industry-specific requirements, legal requirements (e.g., affirmative action or immigration status requirements), or specific local policy requirements. Some Participating Entities may require the use of a Participating Addendum; the terms of which will be negotiated directly between the Participating Entity and the Supplier. Any negotiated additional terms and conditions must never be less favorable to the Participating Entity than what is contained in this Contract.

C. SPECIALIZED SERVICE REQUIREMENTS. In the event that the Participating Entity requires service or specialized performance requirements not addressed in this Contract (such as e-commerce specifications, specialized delivery requirements, or other specifications and requirements), the Participating Entity and the Supplier may enter into a separate, standalone agreement, apart from this Contract. Sourcewell, including its agents and employees, will not be made a party to a claim for breach of such agreement.

D. TERMINATION OF ORDERS. Participating Entities may terminate an order, in whole or in part, immediately upon notice to Supplier in the event of any of the following:

1. The Participating Entity fails to receive funding or appropriation from its governing body at levels sufficient to pay for the equipment, products, or services to be purchased; or
2. Federal, state, or provincial laws or regulations prohibit the purchase or change the Participating Entity's requirements.

E. GOVERNING LAW AND VENUE. The governing law and venue for any action related to a Participating Entity's order will be determined by the Participating Entity making the purchase.

7. CUSTOMER SERVICE

A. PRIMARY ACCOUNT REPRESENTATIVE. Supplier will assign an Account Representative to Sourcewell for this Contract and must provide prompt notice to Sourcewell if that person is changed. The Account Representative will be responsible for:

- Maintenance and management of this Contract;
- Timely response to all Sourcewell and Participating Entity inquiries; and

- Business reviews to Sourcwell and Participating Entities, if applicable.

B. BUSINESS REVIEWS. Supplier must perform a minimum of one business review with Sourcwell per contract year. The business review will cover sales to Participating Entities, pricing and contract terms, administrative fees, sales data reports, supply issues, customer issues, and any other necessary information.

8. REPORT ON CONTRACT SALES ACTIVITY AND ADMINISTRATIVE FEE PAYMENT

A. CONTRACT SALES ACTIVITY REPORT. Each calendar quarter, Supplier must provide a contract sales activity report (Report) to the Sourcwell Supplier Development Administrator assigned to this Contract. Reports are due no later than 45 days after the end of each calendar quarter. A Report must be provided regardless of the number or amount of sales during that quarter (i.e., if there are no sales, Supplier must submit a report indicating no sales were made).

The Report must contain the following fields:

- Participating Entity Name (e.g., City of Staples Highway Department);
- Participating Entity Physical Street Address;
- Participating Entity City;
- Participating Entity State/Province;
- Participating Entity Zip/Postal Code;
- Participating Entity Contact Name;
- Participating Entity Contact Email Address;
- Participating Entity Contact Telephone Number;
- Sourcwell Assigned Entity/Participating Entity Number;
- Item Purchased Description;
- Item Purchased Price;
- Sourcwell Administrative Fee Applied; and
- Date Purchase was invoiced/sale was recognized as revenue by Supplier.

B. ADMINISTRATIVE FEE. In consideration for the support and services provided by Sourcwell, the Supplier will pay an administrative fee to Sourcwell on all Equipment, Products, and Services provided to Participating Entities. The Administrative Fee must be included in, and not added to, the pricing. Supplier may not charge Participating Entities more than the contracted price to offset the Administrative Fee.

The Supplier will submit payment to Sourcwell for the percentage of administrative fee stated in the Proposal multiplied by the total sales of all Equipment, Products, and Services purchased by Participating Entities under this Contract during each calendar quarter. Payments should note the Supplier's name and Sourcwell-assigned contract number in the memo; and must be

mailed to the address above "Attn: Accounts Receivable" or remitted electronically to Sourcewell's banking institution per Sourcewell's Finance department instructions. Payments must be received no later than 45 calendar days after the end of each calendar quarter.

Supplier agrees to cooperate with Sourcewell in auditing transactions under this Contract to ensure that the administrative fee is paid on all items purchased under this Contract.

In the event the Supplier is delinquent in any undisputed administrative fees, Sourcewell reserves the right to cancel this Contract and reject any proposal submitted by the Supplier in any subsequent solicitation. In the event this Contract is cancelled by either party prior to the Contract's expiration date, the administrative fee payment will be due no more than 30 days from the cancellation date.

9. AUTHORIZED REPRESENTATIVE

Sourcewell's Authorized Representative is its Chief Procurement Officer.

Supplier's Authorized Representative is the person named in the Supplier's Proposal. If Supplier's Authorized Representative changes at any time during this Contract, Supplier must promptly notify Sourcewell in writing.

10. AUDIT, ASSIGNMENT, AMENDMENTS, WAIVER, AND CONTRACT COMPLETE

A. **AUDIT.** Pursuant to Minnesota Statutes Section 16C.05, subdivision 5, the books, records, documents, and accounting procedures and practices relevant to this Agreement are subject to examination by Sourcewell or the Minnesota State Auditor for a minimum of six years from the end of this Contract. This clause extends to Participating Entities as it relates to business conducted by that Participating Entity under this Contract.

B. **ASSIGNMENT.** Neither party may assign or otherwise transfer its rights or obligations under this Contract without the prior written consent of the other party and a fully executed assignment agreement. Such consent will not be unreasonably withheld. Any prohibited assignment will be invalid.

C. **AMENDMENTS.** Any amendment to this Contract must be in writing and will not be effective until it has been duly executed by the parties.

D. **WAIVER.** Failure by either party to take action or assert any right under this Contract will not be deemed a waiver of such right in the event of the continuation or repetition of the circumstances giving rise to such right. Any such waiver must be in writing and signed by the parties.

E. **CONTRACT COMPLETE.** This Contract represents the complete agreement between the parties. No other understanding regarding this Contract, whether written or oral, may be used to bind either party. For any conflict between the attached Proposal and the terms set out in Articles 1-22 of this Contract, the terms of Articles 1-22 will govern.

F. **RELATIONSHIP OF THE PARTIES.** The relationship of the parties is one of independent contractors, each free to exercise judgment and discretion with regard to the conduct of their respective businesses. This Contract does not create a partnership, joint venture, or any other relationship such as master-servant, or principal-agent.

11. INDEMNITY AND HOLD HARMLESS

Supplier must indemnify, defend, save, and hold Sourcewell and its Participating Entities, including their agents and employees, harmless from any claims or causes of action, including attorneys' fees incurred by Sourcewell or its Participating Entities, arising out of any act or omission in the performance of this Contract by the Supplier or its agents or employees; this indemnification includes injury or death to person(s) or property alleged to have been caused by some defect in the Equipment, Products, or Services under this Contract to the extent the Equipment, Product, or Service has been used according to its specifications. Sourcewell's responsibility will be governed by the State of Minnesota's Tort Liability Act (Minnesota Statutes Chapter 466) and other applicable law.

12. GOVERNMENT DATA PRACTICES

Supplier and Sourcewell must comply with the Minnesota Government Data Practices Act, Minnesota Statutes Chapter 13, as it applies to all data provided by or provided to Sourcewell under this Contract and as it applies to all data created, collected, received, stored, used, maintained, or disseminated by the Supplier under this Contract.

13. INTELLECTUAL PROPERTY, PUBLICITY, MARKETING, AND ENDORSEMENT

A. INTELLECTUAL PROPERTY

1. *Grant of License.* During the term of this Contract:
 - a. Sourcewell grants to Supplier a royalty-free, worldwide, non-exclusive right and license to use the trademark(s) provided to Supplier by Sourcewell in advertising and promotional materials for the purpose of marketing Sourcewell's relationship with Supplier.
 - b. Supplier grants to Sourcewell a royalty-free, worldwide, non-exclusive right and license to use Supplier's trademarks in advertising and promotional materials for the purpose of marketing Supplier's relationship with Sourcewell.
2. *Limited Right of Sublicense.* The right and license granted herein includes a limited right of each party to grant sublicenses to their respective subsidiaries, distributors, dealers, resellers, marketing representatives, and agents (collectively "Permitted Sublicensees") in

advertising and promotional materials for the purpose of marketing the Parties' relationship to Participating Entities. Any sublicense granted will be subject to the terms and conditions of this Article. Each party will be responsible for any breach of this Article by any of their respective sublicensees.

3. Use; Quality Control.

a. Neither party may alter the other party's trademarks from the form provided and must comply with removal requests as to specific uses of its trademarks or logos.

b. Each party agrees to use, and to cause its Permitted Sublicensees to use, the other party's trademarks only in good faith and in a dignified manner consistent with such party's use of the trademarks. Upon written notice to the breaching party, the breaching party has 30 days of the date of the written notice to cure the breach or the license will be terminated.

4. As applicable, Supplier agrees to indemnify and hold harmless Sourcewell and its Participating Entities against any and all suits, claims, judgments, and costs instituted or recovered against Sourcewell or Participating Entities by any person on account of the use of any Equipment or Products by Sourcewell or its Participating Entities supplied by Supplier in violation of applicable patent or copyright laws.

5. Termination. Upon the termination of this Contract for any reason, each party, including Permitted Sublicensees, will have 30 days to remove all Trademarks from signage, websites, and the like bearing the other party's name or logo (excepting Sourcewell's pre-printed catalog of suppliers which may be used until the next printing). Supplier must return all marketing and promotional materials, including signage, provided by Sourcewell, or dispose of it according to Sourcewell's written directions.

B. **PUBLICITY.** Any publicity regarding the subject matter of this Contract must not be released without prior written approval from the Authorized Representatives. Publicity includes notices, informational pamphlets, press releases, research, reports, signs, and similar public notices prepared by or for the Supplier individually or jointly with others, or any subcontractors, with respect to the program, publications, or services provided resulting from this Contract.

C. **MARKETING.** Any direct advertising, marketing, or offers with Participating Entities must be approved by Sourcewell. Send all approval requests to the Sourcewell Supplier Development Administrator assigned to this Contract.

D. **ENDORSEMENT.** The Supplier must not claim that Sourcewell endorses its Equipment, Products, or Services.

14. GOVERNING LAW, JURISDICTION, AND VENUE

The substantive and procedural laws of the State of Minnesota will govern this Contract. Venue for all legal proceedings arising out of this Contract, or its breach, must be in the appropriate state court in Todd County, Minnesota or federal court in Fergus Falls, Minnesota.

15. FORCE MAJEURE

Neither party to this Contract will be held responsible for delay or default caused by acts of God or other conditions that are beyond that party's reasonable control. A party defaulting under this provision must provide the other party prompt written notice of the default.

16. SEVERABILITY

If any provision of this Contract is found by a court of competent jurisdiction to be illegal, unenforceable, or void then both parties will be relieved from all obligations arising from that provision. If the remainder of this Contract is capable of being performed, it will not be affected by such determination or finding and must be fully performed.

17. PERFORMANCE, DEFAULT, AND REMEDIES

A. **PERFORMANCE.** During the term of this Contract, the parties will monitor performance and address unresolved contract issues as follows:

1. *Notification.* The parties must promptly notify each other of any known dispute and work in good faith to resolve such dispute within a reasonable period of time. If necessary, Sourcewell and the Supplier will jointly develop a short briefing document that describes the issue(s), relevant impact, and positions of both parties.
2. *Escalation.* If parties are unable to resolve the issue in a timely manner, as specified above, either Sourcewell or Supplier may escalate the resolution of the issue to a higher level of management. The Supplier will have 30 calendar days to cure an outstanding issue.
3. *Performance while Dispute is Pending.* Notwithstanding the existence of a dispute, the Supplier must continue without delay to carry out all of its responsibilities under the Contract that are not affected by the dispute. If the Supplier fails to continue without delay to perform its responsibilities under the Contract, in the accomplishment of all undisputed work, the Supplier will bear any additional costs incurred by Sourcewell and/or its Participating Entities as a result of such failure to proceed.

B. **DEFAULT AND REMEDIES.** Either of the following constitutes cause to declare this Contract, or any Participating Entity order under this Contract, in default:

1. Nonperformance of contractual requirements, or
2. A material breach of any term or condition of this Contract.

The party claiming default must provide written notice of the default, with 30 calendar days to cure the default. Time allowed for cure will not diminish or eliminate any liability for liquidated or other damages. If the default remains after the opportunity for cure, the non-defaulting party may:

- Exercise any remedy provided by law or equity, or
- Terminate the Contract or any portion thereof, including any orders issued against the Contract.

18. INSURANCE

A. REQUIREMENTS. At its own expense, Supplier must maintain insurance policy(ies) in effect at all times during the performance of this Contract with insurance company(ies) licensed or authorized to do business in the State of Minnesota having an "AM BEST" rating of A- or better, with coverage and limits of insurance not less than the following:

1. *Workers' Compensation and Employer's Liability.*

Workers' Compensation: As required by any applicable law or regulation.

Employer's Liability Insurance: must be provided in amounts not less than listed below:

Minimum limits:

\$500,000 each accident for bodily injury by accident

\$500,000 policy limit for bodily injury by disease

\$500,000 each employee for bodily injury by disease

2. *Commercial General Liability Insurance.* Supplier will maintain insurance covering its operations, with coverage on an occurrence basis, and must be subject to terms no less broad than the Insurance Services Office ("ISO") Commercial General Liability Form CG0001 (2001 or newer edition), or equivalent. At a minimum, coverage must include liability arising from premises, operations, bodily injury and property damage, independent contractors, products-completed operations including construction defect, contractual liability, blanket contractual liability, and personal injury and advertising injury. All required limits, terms and conditions of coverage must be maintained during the term of this Contract.

Minimum Limits:

\$1,000,000 each occurrence Bodily Injury and Property Damage

\$1,000,000 Personal and Advertising Injury

\$2,000,000 aggregate for Products-Completed operations

\$2,000,000 general aggregate

3. *Commercial Automobile Liability Insurance.* During the term of this Contract, Supplier will maintain insurance covering all owned, hired, and non-owned automobiles in limits of liability not less than indicated below. The coverage must be subject to terms

no less broad than ISO Business Auto Coverage Form CA 0001 (2010 edition or newer), or equivalent.

Minimum Limits:

\$1,000,000 each accident, combined single limit

4. *Umbrella Insurance*. During the term of this Contract, Supplier will maintain umbrella coverage over Employer's Liability, Commercial General Liability, and Commercial Automobile.

Minimum Limits:

\$2,000,000

5. *Professional/Technical, Errors and Omissions, and/or Miscellaneous Professional Liability*. During the term of this Contract, Supplier will maintain coverage for all claims the Supplier may become legally obligated to pay resulting from any actual or alleged negligent act, error, or omission related to Supplier's professional services required under this Contract.

Minimum Limits:

\$2,000,000 per claim or event

\$2,000,000 – annual aggregate

6. *Network Security and Privacy Liability Insurance*. During the term of this Contract, Supplier will maintain coverage for network security and privacy liability. The coverage may be endorsed on another form of liability coverage or written on a standalone policy. The insurance must cover claims which may arise from failure of Supplier's security resulting in, but not limited to, computer attacks, unauthorized access, disclosure of not public data – including but not limited to, confidential or private information, transmission of a computer virus, or denial of service.

Minimum limits:

\$2,000,000 per occurrence

\$2,000,000 annual aggregate

Failure of Supplier to maintain the required insurance will constitute a material breach entitling Sourcwell to immediately terminate this Contract for default.

B. CERTIFICATES OF INSURANCE. Prior to commencing under this Contract, Supplier must furnish to Sourcwell a certificate of insurance, as evidence of the insurance required under this Contract. Prior to expiration of the policy(ies), renewal certificates must be mailed to Sourcwell, 202 12th Street Northeast, P.O. Box 219, Staples, MN 56479 or sent to the Sourcwell Supplier Development Administrator assigned to this Contract. The certificates must be signed by a person authorized by the insurer(s) to bind coverage on their behalf.

Failure to request certificates of insurance by Sourcewell, or failure of Supplier to provide certificates of insurance, in no way limits or relieves Supplier of its duties and responsibilities in this Contract.

C. **ADDITIONAL INSURED ENDORSEMENT AND PRIMARY AND NON-CONTRIBUTORY INSURANCE CLAUSE.** Supplier agrees to list Sourcewell and its Participating Entities, including their officers, agents, and employees, as an additional insured under the Supplier's commercial general liability insurance policy with respect to liability arising out of activities, "operations," or "work" performed by or on behalf of Supplier, and products and completed operations of Supplier. The policy provision(s) or endorsement(s) must further provide that coverage is primary and not excess over or contributory with any other valid, applicable, and collectible insurance or self-insurance in force for the additional insureds.

D. **WAIVER OF SUBROGATION.** Supplier waives and must require (by endorsement or otherwise) all its insurers to waive subrogation rights against Sourcewell and other additional insureds for losses paid under the insurance policies required by this Contract or other insurance applicable to the Supplier or its subcontractors. The waiver must apply to all deductibles and/or self-insured retentions applicable to the required or any other insurance maintained by the Supplier or its subcontractors. Where permitted by law, Supplier must require similar written express waivers of subrogation and insurance clauses from each of its subcontractors.

E. **UMBRELLA/EXCESS LIABILITY/SELF-INSURED RETENTION.** The limits required by this Contract can be met by either providing a primary policy or in combination with umbrella/excess liability policy(ies), or self-insured retention.

19. COMPLIANCE

A. **LAWS AND REGULATIONS.** All Equipment, Products, or Services provided under this Contract must comply fully with applicable federal laws and regulations, and with the laws in the states and provinces in which the Equipment, Products, or Services are sold.

B. **LICENSES.** Supplier must maintain a valid and current status on all required federal, state/provincial, and local licenses, bonds, and permits required for the operation of the business that the Supplier conducts with Sourcewell and Participating Entities.

20. BANKRUPTCY, DEBARMENT, OR SUSPENSION CERTIFICATION

Supplier certifies and warrants that it is not in bankruptcy or that it has previously disclosed in writing certain information to Sourcewell related to bankruptcy actions. If at any time during this Contract Supplier declares bankruptcy, Supplier must immediately notify Sourcewell in writing.

Supplier certifies and warrants that neither it nor its principals are presently debarred, suspended, proposed for debarment, declared ineligible, or voluntarily excluded from programs operated by the State of Minnesota; the United States federal government or the Canadian government, as applicable; or any Participating Entity. Supplier certifies and warrants that neither it nor its principals have been convicted of a criminal offense related to the subject matter of this Contract. Supplier further warrants that it will provide immediate written notice to Sourcwell if this certification changes at any time.

21. PROVISIONS FOR NON-UNITED STATES FEDERAL ENTITY PROCUREMENTS UNDER UNITED STATES FEDERAL AWARDS OR OTHER AWARDS

Participating Entities that use United States federal grant or FEMA funds to purchase goods or services from this Contract may be subject to additional requirements including the procurement standards of the Uniform Administrative Requirements, Cost Principles and Audit Requirements for Federal Awards, 2 C.F.R. § 200. Participating Entities may have additional requirements based on specific funding source terms or conditions. Within this Article, all references to “federal” should be interpreted to mean the United States federal government. The following list only applies when a Participating Entity accesses Supplier’s Equipment, Products, or Services with United States federal funds.

A. **EQUAL EMPLOYMENT OPPORTUNITY.** Except as otherwise provided under 41 C.F.R. § 60, all contracts that meet the definition of “federally assisted construction contract” in 41 C.F.R. § 60-1.3 must include the equal opportunity clause provided under 41 C.F.R. §60-1.4(b), in accordance with Executive Order 11246, “Equal Employment Opportunity” (30 FR 12319, 12935, 3 C.F.R. §, 1964-1965 Comp., p. 339), as amended by Executive Order 11375, “Amending Executive Order 11246 Relating to Equal Employment Opportunity,” and implementing regulations at 41 C.F.R. § 60, “Office of Federal Contract Compliance Programs, Equal Employment Opportunity, Department of Labor.” The equal opportunity clause is incorporated herein by reference.

B. **DAVIS-BACON ACT, AS AMENDED (40 U.S.C. § 3141-3148).** When required by federal program legislation, all prime construction contracts in excess of \$2,000 awarded by non-federal entities must include a provision for compliance with the Davis-Bacon Act (40 U.S.C. § 3141-3144, and 3146-3148) as supplemented by Department of Labor regulations (29 C.F.R. § 5, “Labor Standards Provisions Applicable to Contracts Covering Federally Financed and Assisted Construction”). In accordance with the statute, contractors must be required to pay wages to laborers and mechanics at a rate not less than the prevailing wages specified in a wage determination made by the Secretary of Labor. In addition, contractors must be required to pay wages not less than once a week. The non-federal entity must place a copy of the current prevailing wage determination issued by the Department of Labor in each solicitation. The decision to award a contract or subcontract must be conditioned upon the acceptance of the wage determination. The non-federal entity must report all suspected or reported violations to the federal awarding agency. The contracts must also include a provision for compliance with

the Copeland “Anti-Kickback” Act (40 U.S.C. § 3145), as supplemented by Department of Labor regulations (29 C.F.R. § 3, “Contractors and Subcontractors on Public Building or Public Work Financed in Whole or in Part by Loans or Grants from the United States”). The Act provides that each contractor or subrecipient must be prohibited from inducing, by any means, any person employed in the construction, completion, or repair of public work, to give up any part of the compensation to which he or she is otherwise entitled. The non-federal entity must report all suspected or reported violations to the federal awarding agency. Supplier must be in compliance with all applicable Davis-Bacon Act provisions.

C. CONTRACT WORK HOURS AND SAFETY STANDARDS ACT (40 U.S.C. § 3701-3708). Where applicable, all contracts awarded by the non-federal entity in excess of \$100,000 that involve the employment of mechanics or laborers must include a provision for compliance with 40 U.S.C. §§ 3702 and 3704, as supplemented by Department of Labor regulations (29 C.F.R. § 5). Under 40 U.S.C. § 3702 of the Act, each contractor must be required to compute the wages of every mechanic and laborer on the basis of a standard work week of 40 hours. Work in excess of the standard work week is permissible provided that the worker is compensated at a rate of not less than one and a half times the basic rate of pay for all hours worked in excess of 40 hours in the work week. The requirements of 40 U.S.C. § 3704 are applicable to construction work and provide that no laborer or mechanic must be required to work in surroundings or under working conditions which are unsanitary, hazardous or dangerous. These requirements do not apply to the purchases of supplies or materials or articles ordinarily available on the open market, or contracts for transportation or transmission of intelligence. This provision is hereby incorporated by reference into this Contract. Supplier certifies that during the term of an award for all contracts by Sourcewell resulting from this procurement process, Supplier must comply with applicable requirements as referenced above.

D. RIGHTS TO INVENTIONS MADE UNDER A CONTRACT OR AGREEMENT. If the federal award meets the definition of “funding agreement” under 37 C.F.R. § 401.2(a) and the recipient or subrecipient wishes to enter into a contract with a small business firm or nonprofit organization regarding the substitution of parties, assignment or performance of experimental, developmental, or research work under that “funding agreement,” the recipient or subrecipient must comply with the requirements of 37 C.F.R. § 401, “Rights to Inventions Made by Nonprofit Organizations and Small Business Firms Under Government Grants, Contracts and Cooperative Agreements,” and any implementing regulations issued by the awarding agency. Supplier certifies that during the term of an award for all contracts by Sourcewell resulting from this procurement process, Supplier must comply with applicable requirements as referenced above.

E. CLEAN AIR ACT (42 U.S.C. § 7401-7671Q.) AND THE FEDERAL WATER POLLUTION CONTROL ACT (33 U.S.C. § 1251-1387). Contracts and subgrants of amounts in excess of \$150,000 require the non-federal award to agree to comply with all applicable standards, orders or regulations issued pursuant to the Clean Air Act (42 U.S.C. § 7401- 7671q) and the Federal Water Pollution Control Act as amended (33 U.S.C. § 1251- 1387). Violations must be reported to the Federal awarding agency and the Regional Office of the Environmental Protection Agency (EPA).

Supplier certifies that during the term of this Contract will comply with applicable requirements as referenced above.

F. DEBARMENT AND SUSPENSION (EXECUTIVE ORDERS 12549 AND 12689). A contract award (see 2 C.F.R. § 180.220) must not be made to parties listed on the government wide exclusions in the System for Award Management (SAM), in accordance with the OMB guidelines at 2 C.F.R. §180 that implement Executive Orders 12549 (3 C.F.R. § 1986 Comp., p. 189) and 12689 (3 C.F.R. § 1989 Comp., p. 235), "Debarment and Suspension." SAM Exclusions contains the names of parties debarred, suspended, or otherwise excluded by agencies, as well as parties declared ineligible under statutory or regulatory authority other than Executive Order 12549. Supplier certifies that neither it nor its principals are presently debarred, suspended, proposed for debarment, declared ineligible, or voluntarily excluded from participation by any federal department or agency.

G. BYRD ANTI-LOBBYING AMENDMENT, AS AMENDED (31 U.S.C. § 1352). Suppliers must file any required certifications. Suppliers must not have used federal appropriated funds to pay any person or organization for influencing or attempting to influence an officer or employee of any agency, a member of Congress, officer or employee of Congress, or an employee of a member of Congress in connection with obtaining any federal contract, grant, or any other award covered by 31 U.S.C. § 1352. Suppliers must disclose any lobbying with non-federal funds that takes place in connection with obtaining any federal award. Such disclosures are forwarded from tier to tier up to the non-federal award. Suppliers must file all certifications and disclosures required by, and otherwise comply with, the Byrd Anti-Lobbying Amendment (31 U.S.C. § 1352).

H. RECORD RETENTION REQUIREMENTS. To the extent applicable, Supplier must comply with the record retention requirements detailed in 2 C.F.R. § 200.333. The Supplier further certifies that it will retain all records as required by 2 C.F.R. § 200.333 for a period of 3 years after grantees or subgrantees submit final expenditure reports or quarterly or annual financial reports, as applicable, and all other pending matters are closed.

I. ENERGY POLICY AND CONSERVATION ACT COMPLIANCE. To the extent applicable, Supplier must comply with the mandatory standards and policies relating to energy efficiency which are contained in the state energy conservation plan issued in compliance with the Energy Policy and Conservation Act.

J. BUY AMERICAN PROVISIONS COMPLIANCE. To the extent applicable, Supplier must comply with all applicable provisions of the Buy American Act. Purchases made in accordance with the Buy American Act must follow the applicable procurement rules calling for free and open competition.

K. ACCESS TO RECORDS (2 C.F.R. § 200.336). Supplier agrees that duly authorized representatives of a federal agency must have access to any books, documents, papers and

records of Supplier that are directly pertinent to Supplier's discharge of its obligations under this Contract for the purpose of making audits, examinations, excerpts, and transcriptions. The right also includes timely and reasonable access to Supplier's personnel for the purpose of interview and discussion relating to such documents.

L. **PROCUREMENT OF RECOVERED MATERIALS (2 C.F.R. § 200.322).** A non-federal entity that is a state agency or agency of a political subdivision of a state and its contractors must comply with Section 6002 of the Solid Waste Disposal Act, as amended by the Resource Conservation and Recovery Act. The requirements of Section 6002 include procuring only items designated in guidelines of the Environmental Protection Agency (EPA) at 40 C.F.R. § 247 that contain the highest percentage of recovered materials practicable, consistent with maintaining a satisfactory level of competition, where the purchase price of the item exceeds \$10,000 or the value of the quantity acquired during the preceding fiscal year exceeded \$10,000; procuring solid waste management services in a manner that maximizes energy and resource recovery; and establishing an affirmative procurement program for procurement of recovered materials identified in the EPA guidelines.

M. **FEDERAL SEAL(S), LOGOS, AND FLAGS.** The Supplier not use the seal(s), logos, crests, or reproductions of flags or likenesses of Federal agency officials without specific pre-approval.

N. **NO OBLIGATION BY FEDERAL GOVERNMENT.** The U.S. federal government is not a party to this Contract or any purchase by an Participating Entity and is not subject to any obligations or liabilities to the Participating Entity, Supplier, or any other party pertaining to any matter resulting from the Contract or any purchase by an authorized user.

O. **PROGRAM FRAUD AND FALSE OR FRAUDULENT STATEMENTS OR RELATED ACTS.** The Contractor acknowledges that 31 U.S.C. 38 (Administrative Remedies for False Claims and Statements) applies to the Supplier's actions pertaining to this Contract or any purchase by a Participating Entity.

P. **FEDERAL DEBT.** The Supplier certifies that it is non-delinquent in its repayment of any federal debt. Examples of relevant debt include delinquent payroll and other taxes, audit disallowance, and benefit overpayments.

Q. **CONFLICTS OF INTEREST.** The Supplier must notify the U.S. Office of General Services, Sourcewell, and Participating Entity as soon as possible if this Contract or any aspect related to the anticipated work under this Contract raises an actual or potential conflict of interest (as described in 2 C.F.R. Part 200). The Supplier must explain the actual or potential conflict in writing in sufficient detail so that the U.S. Office of General Services, Sourcewell, and Participating Entity are able to assess the actual or potential conflict; and provide any additional information as necessary or requested.

R. U.S. EXECUTIVE ORDER 13224. The Supplier, and its subcontractors, must comply with U.S. Executive Order 13224 and U.S. Laws that prohibit transactions with and provision of resources and support to individuals and organizations associated with terrorism.

S. PROHIBITION ON CERTAIN TELECOMMUNICATIONS AND VIDEO SURVEILLANCE SERVICES OR EQUIPMENT. To the extent applicable, Supplier certifies that during the term of this Contract it will comply with applicable requirements of 2 C.F.R. § 200.216.

T. DOMESTIC PREFERENCES FOR PROCUREMENTS. To the extent applicable, Supplier certifies that during the term of this Contract will comply with applicable requirements of 2 C.F.R. § 200.322.

22. CANCELLATION

Sourcewell or Supplier may cancel this Contract at any time, with or without cause, upon 60 days' written notice to the other party. However, Sourcewell may cancel this Contract immediately upon discovery of a material defect in any certification made in Supplier's Proposal. Cancellation of this Contract does not relieve either party of financial, product, or service obligations incurred or accrued prior to cancellation.

Sourcewell

Lexipol, LLC

DocuSigned by:
Jeremy Schwartz
By: C0FD2A139D06489...
Jeremy Schwartz
Title: Chief Procurement Officer
Date: 3/18/2022 | 4:07 PM CDT

DocuSigned by:
Van Holland
By: E730CB10CB894D6...
Van Holland
Title: Chief Financial Officer
Date: 3/28/2022 | 2:52 PM PDT

Approved:

DocuSigned by:
Chad Coauette
By: 7E42B8F817A64CC...
Chad Coauette
Title: Executive Director/CEO
Date: 3/28/2022 | 5:23 PM CDT

RFP 011822 - Public Safety Training and Simulation Equipment and Technology

Vendor Details

Company Name: Lexipol, LLC
Address: 2611 Internet Blvd Suite 100
Frisco, Texas 75034
Contact: Linda Ortiz
Email: lortiz@lexipol.com
Phone: 954-629-6957
Fax: 404-886-5652
HST#: EIN 71-0934113

Submission Details

Created On: Friday January 14, 2022 12:26:40
Submitted On: Tuesday January 18, 2022 14:17:10
Submitted By: Jeff Oathout
Email: joathout@lexipol.com
Transaction #: 21ad5a82-2382-429a-b8fd-07c0459b07d5
Submitter's IP Address: 107.3.202.156

Specifications

Table 1: Proposer Identity & Authorized Representatives

General Instructions (applies to all Tables) Sourcewell prefers a brief but thorough response to each question. Do not merely attach additional documents to your response without also providing a substantive response. Do not leave answers blank; respond "N/A" if the question does not apply to you (preferably with an explanation).

Line Item	Question	Response *
1	Proposer Legal Name (one legal entity only): (In the event of award, will execute the resulting contract as "Supplier")	Lexipol, LLC
2	Identify all subsidiary entities of the Proposer whose equipment, products, or services are included in the Proposal.	Lexipol, LLC
3	Identify all applicable assumed names or DBA names of the Proposer or Proposer's subsidiaries in Line 1 or Line 2 above.	Lexipol, LLC
4	Provide your CAGE code or DUNS number:	CAGE Code 4J5F4 DUNS Number 146103077
5	Proposer Physical Address:	2611 Internet Blvd Suite 100 Frisco, TX 75034
6	Proposer website address (or addresses):	https://www.lexipol.com/
7	Proposer's Authorized Representative (name, title, address, email address & phone) (The representative must have authority to sign the "Proposer's Assurance of Compliance" on behalf of the Proposer and, in the event of award, will be expected to execute the resulting contract):	Van Holland Chief Financial Officer 2611 Internet Blvd Suite 100 Frisco, TX 75034 vholland@lexipol.com 9493508040
8	Proposer's primary contact for this proposal (name, title, address, email address & phone):	Linda Ortiz Director of Sales - Fire/EMS Learning 2611 Internet Blvd Suite 100 Frisco, TX 75034 lortiz@lexipol.com 4159924246
9	Proposer's other contacts for this proposal, if any (name, title, address, email address & phone):	Jeff Oathout Director of Sales - Fire Policy 2611 Internet Blvd Suite 100 Frisco, TX 75034 4048865652

Table 2: Company Information and Financial Strength

Line Item	Question	Response *
10	Provide a brief history of your company, including your company's core values, business philosophy, and industry longevity related to the requested equipment, products or services.	Lexipol is the industry leading provider of policy, procedure, online training, wellness, and grant services for public safety. Lexipol was founded in 2003 by Gordon Graham and Bruce Praet, both former law enforcement officers and attorneys with extensive experience in risk management. Mr. Graham and Mr. Praet identified that many public safety agencies lack sound, up-to-date, constitutionally sound policies. To address this need, they developed comprehensive, state-specific public safety policy manuals backed by daily training to reinforce policy understanding and use. Today, Lexipol serves more than 8,000 public safety and local government organizations in 50 states, Canada and five industries: fire and rescue, law enforcement, corrections, emergency medical services (EMS) and local government. The company serves more than 2 million public safety and government professionals with a range of informational and technological solutions to meet the challenges facing these dynamic industries.
11	What are your company's expectations in the event of an award?	To have an opportunity to increase exposure and provide a streamlined procurement process for public safety and local government agencies evaluating and selecting an online learning and policy training solution.

12	Demonstrate your financial strength and stability with meaningful data. This could include such items as financial statements, SEC filings, credit and bond ratings, letters of credit, and detailed reference letters. Upload supporting documents (as applicable) in the document upload section of your response.	Lexipol has been in business for over 19 years, is profitable and are backed by GTCR, a global private equity firm with over \$16.6 billion in assets under management.	*
13	What is your US market share for the solutions that you are proposing?	13%	*
14	What is your Canadian market share for the solutions that you are proposing?	>5%	*
15	Has your business ever petitioned for bankruptcy protection? If so, explain in detail.	No	*
16	How is your organization best described: is it a manufacturer, a distributor/dealer/reseller, or a service provider? Answer whichever question (either a) or b) just below) best applies to your organization. a) If your company is best described as a distributor/dealer/reseller (or similar entity), provide your written authorization to act as a distributor/dealer/reseller for the manufacturer of the products proposed in this RFP. If applicable, is your dealer network independent or company owned? b) If your company is best described as a manufacturer or service provider, describe your relationship with your sales and service force and with your dealer network in delivering the products and services proposed in this RFP. Are these individuals your employees, or the employees of a third party?	<p>Service Provider</p> <p>b) SALES TEAM We know what it means to serve. Lexipol currently employs a team of dedicated individuals who represent a combined 2,075 years of experience in public safety. With principal offices in Dallas and California and remote team members nationwide, Lexipol offers a vibrant culture and growth-oriented environment where talented employees develop hands-on experience in technology, marketing, editorial, production, product development, operations, and business management—while also watching firsthand how their efforts enable our customers to save lives and protect our communities.</p> <p>PROJECT TEAM</p> <p>Professional Services Implementation Every department and agency will participate in an onboarding process conducted by our Professional Service Implementation team. This group of passionate professionals focuses on product implementation, initial training on the platform features, technical support, and reporting.</p> <ul style="list-style-type: none"> This team is led by Bill McAuliffe, Director Professional Service, BMcAuliffe@Lexipol.com <p>Customer Success Manager (CSM) Every agency will be assigned a dedicated CSM. The CSM is the primary point of contact for all organization personnel. The CSM provides ongoing training and support in terms of web-based demonstrations of new features, training plan and daily training bulletin guidance, assistance in course and content development, uploading documents and all matters related to the end users.</p> <ul style="list-style-type: none"> This team is led by Brandon Almdarez, Director Customer Success, BAlemdarez@Lexipol.com <p>Lexipol Policy Content Review Team Lexipol assists its customers by leveraging a team of dedicated individuals with experience in constitutional law, civil rights, ADA and discrimination, mental health, psychology, labor negotiations, internal affairs, hazmat and more. This team reviewed more than 15,000 pieces of legislation and regulatory changes last year.</p>	*
17	If applicable, provide a detailed explanation outlining the licenses and certifications that are both required to be held, and actually held, by your organization (including third parties and subcontractors that you use) in pursuit of the business contemplated by this RFP.	None	*
18	Provide all "Suspension or Debarment" information that has applied to your organization during the past ten years.	To the organization's knowledge, there is no suspension or debarment information which applies to the organization.	*

Table 3: Industry Recognition & Marketplace Success

Line Item	Question	Response *
19	Describe any relevant industry awards or recognition that your company has received in the past five years	<p>"Since 2017, Lexipol has received more than 20 awards for our policy management and wellness solutions, corporate actions in response to COVID, and analysis and commentary on our media sites. Some highlights include:</p> <p>COVID Response In March 2020 Lexipol introduced the Coronavirus Learning & Policy Center, which provides public safety agencies free access to a Learning Management System with online courses, policies, and grant assistance related to the pandemic. The Center has won multiple awards, including: -Gold for Corporate Social Responsibility, 2021 MUSE Creative Awards -Silver Award for Company Response of the Year to COVID-19 in the Globee® Awards 13th Annual 2021 Golden Bridge Business and Innovation Awards -Silver Stevie® Award in the 17th Annual International Business Awards® (2020) -Social Impact Award in the ParDreamies award program hosted by Sercante, a Salesforce partner (2021)</p> <p>General -Winner, 2021 Business Intelligence Group Innovation Awards. Lexipol was recognized for its vision, creativity and persistence through continued innovation in public safety and its active, effective response to the rapidly changing events of 2020.</p> <p>Wellness App (Cordico) -2021 Sacramento Region Innovation Award in the Government, Civic and Mobility category -Named a vetted and approved product by the Fraternal Order of Police (FOP) Division of Wellness Services, making it among the very first wellness products approved by the FOP</p> <p>Media Sites Lexipol's media sites, including FireRescue1, EMS1 and Police1, have been recognized for editorial excellence for nine consecutive years with 18 awards, including: -Best News Feature in the 2021 International Association of Fire Fighters (IAFF) Media Awards -2021 Eddie Award for Best Overall B2B Column in the 2021 FOLIO: Eddie & Ozzie Awards -2020 Eddie Award for Best Newsletter (B2B) for the Leadership Briefing - Police1 -2020 Eddie Award for Best Column/Blog (B2B) for its "From the Editorial Director" column by Greg Friese, an educator, author and national registry paramedic - EMS1</p> <p>Policy Management -Finalist in the 2021 Software as a Services (SaaS) Awards program in the Best SaaS Product for Health & Safety or Risk Management category"</p>
20	What percentage of your sales are to the governmental sector in the past three years	98%
21	What percentage of your sales are to the education sector in the past three years	2%
22	List any state, provincial, or cooperative purchasing contracts that you hold. What is the annual sales volume for each of these contracts over the past three years?	While the organization participates in certain cooperative purchasing agreements, the specific nature of each (and particularly including sales volume and/or revenue figures) are confidential and may not be disclosed through a proposal process.
23	List any GSA contracts or Standing Offers and Supply Arrangements (SOSA) that you hold. What is the annual sales volume for each of these contracts over the past three years?	None

Table 4: References/Testimonials

Line Item 24. Supply reference information from three customers who are eligible to be Sourcewell participating entities.

Entity Name *	Contact Name *	Phone Number *	
Clayton County Emergency Services (GA)	Chief of Staff Laura Richardson	770-473-7833	*
Lubbock Fire Rescue (TX)	Captain Randy Lammons	806-775-3447	*
Sedona Fire District (AZ)	Captain Michael Duran	928-600-9042	*

Table 5: Top Five Government or Education Customers

Line Item 25. Provide a list of your top five government, education, or non-profit customers (entity name is optional), including entity type, the state or province the entity is located in, scope of the project(s), size of transaction(s), and dollar volumes from the past three years.

Entity Name	Entity Type *	State / Province *	Scope of Work *	Size of Transactions *	Dollar Volume Past Three Years *	
Hillsborough County Fire Rescue	Government	Florida - FL	Policy & Training	1,000 users	N/R	*
Suffolk County Police Department	Government	New York - NY	Policy & Training	2,700 users	N/R	*
University Hospital Systems Cleveland	Education	Ohio - OH	Learning Management System	6,590 users	N/R	*
Austin Fire Department	Government	Texas - TX	Learning Management System	1,700 users	N/R	*
Dallas Police Department	Government	Texas - TX	Learning Management System	3,275 users	N/R	*

Table 6: Ability to Sell and Deliver Service

Describe your company's capability to meet the needs of Sourcewell participating entities across the US and Canada, as applicable. Your response should address in detail at least the following areas: locations of your network of sales and service providers, the number of workers (full-time equivalents) involved in each sector, whether these workers are your direct employees (or employees of a third party), and any overlap between the sales and service functions.

Line Item	Question	Response *	
26	Sales force.	We know what it means to serve. Lexipol currently employs a team of dedicated individuals who represent a combined 2,075 years of experience in public safety. With principal offices in Dallas and California and remote team members nationwide, Lexipol offers a vibrant culture and growth-oriented environment where talented employees develop hands-on experience in technology, marketing, editorial, production, product development, operations, and business management—while also watching firsthand how their efforts enable our customers to save lives and protect our communities.	*
27	Dealer network or other distribution methods.	ESO Channel Partner Agreement. Since 2004 ESO created innovative software to meet the changing needs of EMS agencies, fire departments, hospitals, and state EMS offices.	*

28	Service force.	<p>Professional Services Implementation</p> <p>Every department and agency will participate in an onboarding process conducted by our Professional Service Implementation team. This group of passionate professionals focuses on product implementation, initial training on the platform features, technical support, and reporting.</p> <ul style="list-style-type: none"> This team is led by Bill McAuliffe, Director Professional Service, BMAuliffe@Lexipol.com <p>Customer Success Manager (CSM)</p> <p>Every agency will be assigned a dedicated CSM. The CSM is the primary point of contact for all organization personnel. The CSM provides ongoing training and support in terms of web-based demonstrations of new features, training plan and daily training bulletin guidance, assistance in course and content development, uploading documents and all matters related to the end users.</p> <ul style="list-style-type: none"> This team is led by Brandon Almendarez, Director Customer Success, BAlemdarez@Lexipol.com <p>Lexipol Policy Content Review Team</p> <p>Lexipol assists its customers by leveraging a team of dedicated individuals with experience in constitutional law, civil rights, ADA and discrimination, mental health, psychology, labor negotiations, internal affairs, hazmat and more. This team reviewed more than 15,000 pieces of legislation and regulatory changes last year.</p> <p>LOCAL SERVICE SUPPORT</p> <p>Client Support Resources and Hours</p> <ul style="list-style-type: none"> Hours 7 am – 7 pm CT Online help video library 24/7 Email messaging direct to support team 	*
29	Describe the ordering process. If orders will be handled by distributors, dealers or others, explain the respective roles of the Proposer and others.	ESO may initiate purchases under this agreement only by submitting purchase orders to Lexipol with each purchase order to specify the buying organization name, product type and pricing.	*
30	Describe in detail the process and procedure of your customer service program, if applicable. Include your response-time capabilities and commitments, as well as any incentives that help your providers meet your stated service goals or promises.	<p>360 Implementation</p> <p>1. Welcome</p> <p>Welcome email ("Welcome – Next Steps")</p> <p>Account setup - Return completed agency roster</p> <p>Onboarding - Schedule through email link a time convenient for you</p> <p>2.Implementation</p> <p>Attend 1:1 implementation meeting with Lexipol specialist</p> <p>Introduction to learning platform</p> <p>Define and complete implementation goals and feature setup</p> <p>Review user management processes</p> <p>Review library of courses and videos</p> <p>3. Ongoing Customer Support</p> <p>Meet your designated Customer Success Manager</p> <ul style="list-style-type: none"> Make account changes (e.g., new users) Answer account and services-related questions Learn about content and platform enhancements <p>4. Professional Services Support (Annual)</p> <p>Review annual plans</p> <p>Review recertification requirements</p> <p>Discuss department changes and needs</p> <p>Implement new features</p>	*
31	Describe your ability and willingness to provide your products and services to Sourcwell participating entities in the United States.	Lexipol's online learning solution is available in all 50 states. Our policy and policy training solution is available in 35 states (LE) / 28 states (Fire) / 31 states (Corrections) / national (GOV) due to maintaining state legislative content compliance. Lexipol will leverage its marketing, sales development and sales team resources to support Sourcwell participating entities.	*
32	Describe your ability and willingness to provide your products and services to Sourcwell participating entities in Canada.	Lexipol is able to offer our online learning solution and course content throughout Canada. We will leverage our marketing, sales development and sales team resources to support Sourcwell participating entities.	*
33	Identify any geographic areas of the United States or Canada that you will NOT be fully serving through the proposed contract.	Lexipol's online learning solution is available in all 50 states. Our policy and policy training solution is available in 35 states (LE) / 28 states (Fire) / 31 states (Corrections) / national (GOV) due to maintaining state legislative content compliance.	*
34	Identify any Sourcwell participating entity sectors (i.e., government, education, not-for-profit) that you will NOT be fully serving through the proposed contract. Explain in detail. For example, does your company have only a regional presence, or do other cooperative purchasing contracts limit your ability to promote another contract?	None	*

35	Define any specific contract requirements or restrictions that would apply to our participating entities in Hawaii and Alaska and in US Territories.	None	*
----	--	------	---

Table 7: Marketing Plan

Line Item	Question	Response *	
36	Describe your marketing strategy for promoting this contract opportunity. Upload representative samples of your marketing materials (if applicable) in the document upload section of your response.	<p>Lexipol uses multiple channels to drive leads and product awareness, including thought leadership content, email campaigns and exhibition at more than 100 national, regional, and state trade shows in the public safety and local government sector. Leads are moved through a scoring process that considers the level of engagement and the contact's decision-making authority. Once leads are qualified, our Sales Development Representatives use one-on-one engagement to schedule product demos. Sales Account Executives present the product demos and follow up to answer any remaining questions and provide additional collateral to support the sales process.</p> <p>Lexipol's marketing plan will be multifaceted and widespread. Lexipol will start with a website announcement of the partnership which allows organizations to leverage Sourcewell's Cooperative Purchasing program for the acquisition of Lexipol products and services. This announcement will be published on all media resources to include FireRescue1, EMS1, Police1, and several others to provide for available media saturation. Lexipol will then initiate a marketing campaign announcing to current and potential agencies that Lexipol is doing business with Sourcewell and that we now have an additional purchasing option to help them not only acquire Lexipol products and services but streamline and accelerate the purchasing by avoiding RFP process. There will also be virtual and tangible collateral that will be made available to Lexipol's robust Sales Teams to share at conferences and trade shows demonstrating the relationship with Sourcewell. The Sales Team will also participate in initial and ongoing training to encourage organizations to leverage the Sourcewell program during the sales process.</p> <p>Along with the Sales Team, the Lexipol Grants Team will offer Sourcewell as an option when assisting agencies applying for grants to purchase Lexipol products.</p>	*
37	Describe your use of technology and digital data (e.g., social media, metadata usage) to enhance marketing effectiveness.	<p>Lexipol employs a comprehensive technology and digital marketing strategy to enhance brand awareness and guide leads through the marketing funnel to sales closure. Through our marketing automation system, Pardot, we monitor and track campaign effectiveness and employ strategies such as optimizing send time for marketing emails based on the user's engagement history. All emails, advertisements, and thought leadership offerings are assigned campaigns in Salesforce, which are then tracked to show campaign influence in creating sales opportunities. Marketing efforts are analyzed monthly and finetuned based on prior campaign effectiveness. At the heart of Lexipol's marketing efforts is our commitment to producing high-quality thought leadership - webinars, white papers, explainers, ebooks, blog articles and more - that build trust in the Lexipol brand and provide ways for future customers to engage with Lexipol. These "top of the funnel" leads are then scored and nurtured through the sales journey. Lexipol also uses digital advertising - both on our own media sites as well as in external industry media - to build awareness, remain top of mind and drive leads. All digital content, such as blogs and webinars, is optimized for online search with keywords, image tags and title tags. Lexipol also maintains an active social media presence, reaching audiences several times daily with thought leadership, product promotions and customer testimonials as well as boosting our partners' messages.</p>	*
38	In your view, what is Sourcewell's role in promoting contracts arising out of this RFP? How will you integrate a Sourcewell-awarded contract into your sales process?	<p>Sourcewell's role upon contract award will be helping Lexipol streamline procurement processes, reduce the need for RFP response and provide a portal for agencies to search our products and connect to purchase. Lexipol utilizes an agency centered consultative process that helps agencies determine the most appropriate process to secure our services which will include leveraging the Sourcewell contract.</p>	*
39	Are your products or services available through an e-procurement ordering process? If so, describe your e-procurement system and how governmental and educational customers have used it.	<p>Lexipol provides an e-procurement solution for individuals (not agencies) in need of continuing education to maintain EMS certification.</p>	*

Table 8: Value-Added Attributes

Line Item	Question	Response *
40	Describe any product, equipment, maintenance, or operator training programs that you offer to Sourcewell participating entities. Include details, such as whether training is standard or optional, who provides training, and any costs that apply.	Training for use of the products is conducted virtually by Lexipol's Professional Services Team. Customers receive training to ensure that they have a thorough knowledge of the platforms and how to operate within them. Product training is included in the prices provided.
41	Describe any technological advances that your proposed products or services offer.	Both the Learning Management Systems and The Knowledge Management System is compatible across almost all devices. The KMS is available in Android and IOS apps for smartphones and tablets. The technology will read the content to the users as well as have the availability to voice search content.
42	Describe any "green" initiatives that relate to your company or to your products or services, and include a list of the certifying agency for each.	N/A
43	Identify any third-party issued eco-labels, ratings or certifications that your company has received for the equipment or products included in your Proposal related to energy efficiency or conservation, life-cycle design (cradle-to-cradle), or other green/sustainability factors.	N/A
44	Describe any Women or Minority Business Entity (WMBE), Small Business Entity (SBE), or veteran owned business certifications that your company or hub partners have obtained. Upload documentation of certification (as applicable) in the document upload section of your response.	N/A
45	What unique attributes does your company, your products, or your services offer to Sourcewell participating entities? What makes your proposed solutions unique in your industry as it applies to Sourcewell participating entities?	Lexipol is unique in its ability to offer public safety and local government a comprehensive way to manage risk and develop safer, more effective personnel. Our online training, policy management and wellness solutions work together to prepare employees for the high-risk, low-frequency events that lead to the greatest harm and costs. We also bring unprecedented experience to our products, with a staff representing thousands of years of collective public safety, government and legal experience. These employees provide expertise in constitutional law, civil rights, ADA and discrimination, mental health, psychology, labor negotiations, Internal Affairs, use of force, hazmat and more. Lexipol's online training is unique in its scope - more than 3,300 accredited training courses. Our policy management platform is the only solution available to public safety agencies that provides continuous monitoring for new state and federal legislation and electronic policy updates; our legal and content teams reviewed more than 15,430 new laws and regulations in 2021, resulting in more than 660 policy updates. And our award-winning wellness app provides an industry-leading confidentiality promise while connecting personnel to life-saving assessments, wellness guides and 24/7 crisis services. Finally, Lexipol's Grant Services division helps public safety agencies and local government identify and apply for grants, with more than \$300 million in grant funding secured for a wide array of products - many of which can be sourced through Sourcewell. This means Sourcewell participating entities will not only be able to access Lexipol's products and services, but will also have the opportunity to obtain grant funding that can be used to purchase other products as well. With Lexipol, Sourcewell participating entities will have access to a range of resources and subject matter expertise far beyond what is found in the typical public safety or government agency.

Table 9A: Warranty

Describe in detail your manufacturer warranty program, including conditions and requirements to qualify, claims procedure, and overall structure. You may upload representative samples of your warranty materials (if applicable) in the document upload section of your response in addition to responding to the questions below.

Line Item	Question	Response *	
46	Do your warranties cover all products, parts, and labor?	Yes	*
47	Do your warranties impose usage restrictions or other limitations that adversely affect coverage?	No	*
48	Do your warranties cover the expense of technicians' travel time and mileage to perform warranty repairs?	N/A	*
49	Are there any geographic regions of the United States or Canada (as applicable) for which you cannot provide a certified technician to perform warranty repairs? How will Sourcewell participating entities in these regions be provided service for warranty repair?	No	*
50	Will you cover warranty service for items made by other manufacturers that are part of your proposal, or are these warranties issues typically passed on to the original equipment manufacturer?	N/A	*
51	What are your proposed exchange and return programs and policies?	N/A	*
52	Describe any service contract options for the items included in your proposal.	N/A	*

Table 9B: Performance Standards or Guarantees

Describe in detail your performance standards or guarantees, including conditions and requirements to qualify, claims procedure, and overall structure. You may upload representative samples of your performance materials (if applicable) in the document upload section of your response in addition to responding to the questions below.

Line Item	Question	Response *
53	Describe any performance standards or guarantees that apply to your services	<p>Uptime Commitment</p> <p>The Uptime Percentage for the Service will be ninety-nine and five-tenths percent (99.5%) (the "Uptime Commitment"). Subject to the exclusions described in below "Uptime Percentage", the percentage is calculated by subtracting from 100% the percentage of 1-minute periods during any annual billing cycle in which Agency's selected Service(s) are unavailable out of the total number of minutes in that billing cycle. "Unavailable" and "Unavailability" mean that, in any 1-minute period, all connection requests received by Agency failed to process (each a "Failed Connection"); provided, however, that no Failed Connection will be counted as a part of more than one such 1-minute period (i.e. a Failed Connection will not be counted for the period 12:00:00-12:00:59 and the period 12:00:30-12:01:29). The Yearly Uptime Percentage will be measure based on the industry standard monitoring tools.</p> <p>Exclusions from Uptime Performance</p> <p>All Service Unavailability resulting from the following will be excluded from calculation of Uptime Percentage: (a) Regularly-scheduled maintenance of the Service that does not exceed six (6) hours per 3-month period and is communicated by Lexipol at least twenty-four (24) hours in advance via Lexipol's support channels (Lexipol typically schedules such regularly scheduled maintenance once per month); (b) Any failures of the Lexipol Standard and Custom Reporting Services that does not exceed six (6) hours per 3-month period and is communicated by Lexipol at least twenty-four (24) hours in advance via Lexipol's Normal Support Channels; (c) Any issues with a third-party service to which Agency subscribes but does not control; (d) Any problems not caused by Lexipol that result from, computing or networking hardware, other equipment or software under Agency's control, the Internet, or other issues with electronic communications; (e) Lexipol's suspension or termination of the Service in accordance with the Terms; (f) Exceeding Lexipol's published Concurrent Request Limits; (g) Software that has been subject to unauthorized modification by Agency; (h) Negligent or intentional misuse of the Service by Agency.</p>
54	Describe any service standards or guarantees that apply to your services (policies, metrics, KPIs, etc.)	For issues relating to Lexipol's online, cloud-based Services (e.g. LMS, LMS, Wellness), Lexipol will make an industry standard and commercially reasonable effort to respond promptly (via Lexipol's Normal Support Channels) within two (2) Business Days after receipt.

Table 10: Payment Terms and Financing Options

Line Item	Question	Response *
55	Describe your payment terms and accepted payment methods.	Lexipol will invoice Agency at the commencement of the contract term and thirty (30) days prior to the date for each renewal period, as applicable. Agency will pay to Lexipol the fee(s) specified on each invoice within thirty (30) days following receipt of the invoice. All invoices will be sent to Agency at the address designated by Agency in writing. All payments will be made by electronic transfer or immediately available funds or by mailing a check to Lexipol at 2611 Internet Blvd, Ste 100, Frisco, TX 75034 (Attn: Accounts Receivable).
56	Describe any leasing or financing options available for use by educational or governmental entities.	None
57	Describe any standard transaction documents that you propose to use in connection with an awarded contract (order forms, terms and conditions, service level agreements, etc.). Upload a sample of each (as applicable) in the document upload section of your response.	Lexipol will include the following documents in an executable contract (see examples in upload section): Master Service Agreement including product form, terms and conditions, and cloud based service level agreement
58	Do you accept the P-card procurement and payment process? If so, is there any additional cost to Sourcwell participating entities for using this process?	No, Lexipol accepts ACH and check payments.

Table 11: Pricing and Delivery

Provide detailed pricing information in the questions that follow below. Keep in mind that reasonable price and product adjustments can be made during the term of an awarded Contract as described in the RFP, the template Contract, and the Sourcewell Price and Product Change Request Form.

Line Item	Question	Response *
59	Describe your pricing model (e.g., line-item discounts or product-category discounts). Provide detailed pricing data (including standard or list pricing and the Sourcewell discounted price) on all of the items that you want Sourcewell to consider as part of your RFP response. If applicable, provide a SKU for each item in your proposal. Upload your pricing materials (if applicable) in the document upload section of your response.	Contracts awarded under this agreement will be given a 5% discount on each line item of the contract. Contracts contain annual subscriptions, proration, and/or implementation depending on the terms agreed to during the sale process. The discount awarded through this agreement will not be added to other discounts provided but will be the minimum discount given when utilizing the agreement. Detail pricing uploaded in documents section of proposal.
60	Quantify the pricing discount represented by the pricing proposal in this response. For example, if the pricing in your response represents a percentage discount from MSRP or list, state the percentage or percentage range.	Contracts awarded under this agreement will be given a 5% discount on each line item of the contract. Contracts contain annual subscriptions, proration, and/or implementation depending on the terms agreed to during the sale process. The discount awarded through this agreement will not be added to other discounts provided but will be the minimum discount given when utilizing the agreement.
61	Describe any quantity or volume discounts or rebate programs that you offer.	N/A
62	Propose a method of facilitating "sourced" products or related services, which may be referred to as "open market" items or "nonstandard options". For example, you may supply such items "at cost" or "at cost plus a percentage," or you may supply a quote for each such request.	N/A
63	Identify any element of the total cost of acquisition that is NOT included in the pricing submitted with your response. This includes all additional charges associated with a purchase that are not directly identified as freight or shipping charges. For example, list costs for items like pre-delivery inspection, installation, set up, mandatory training, or initial inspection. Identify any parties that impose such costs and their relationship to the Proposer.	Implementation Policy implementation is based on a flexible pricing model that reflects the project's potential timeline and scope, which can range from a basic policy cross-reference to full implementation assistance. Several factors are used to determine pricing, including level of assistance requested by the organization, page count of current organizational content, number of employees and organization's legal involvement. This information is obtained during the sales process and the implementation pricing is disclosed to the organization prior to contract execution. Implementation services are a one-time incurred cost (not a recurring subscription).
64	If freight, delivery, or shipping is an additional cost to the Sourcewell participating entity, describe in detail the complete freight, shipping, and delivery program.	N/A
65	Specifically describe freight, shipping, and delivery terms or programs available for Alaska, Hawaii, Canada, or any offshore delivery.	N/A
66	Describe any unique distribution and/or delivery methods or options offered in your proposal.	N/A

Table 12: Pricing Offered

Line Item	The Pricing Offered in this Proposal is: *	Comments
67	d. other than what the Proposer typically offers (please describe).	Purchases acquired as a result of this contract will not only receive a 5% discount on annual subscription (which is typical), they will receive a 5% discount on all professional/implementation services which deviates from traditional agreements.

Table 13: Audit and Administrative Fee

Line Item	Question	Response *
68	Specifically describe any self-audit process or program that you plan to employ to verify compliance with your proposed Contract with Sourcewell. This process includes ensuring that Sourcewell participating entities obtain the proper pricing, that the Vendor reports all sales under the Contract each quarter, and that the Vendor remits the proper administrative fee to Sourcewell. Provide sufficient detail to support your ability to report quarterly sales to Sourcewell as described in the Contract template.	Lexipol will create a Sourcewell designation and coinciding pricing in our client records management system to ensure all Sourcewell contract opportunities are appropriately priced and tracked. A Sourcewell contract report will be generated each quarter to ensure accuracy of pricing and administrative fees paid.
69	If you are awarded a contract, provide a few examples of internal metrics that will be tracked to measure whether you are having success with the contract.	Sales cycle durations, number of RFP responses, sales goal attainment by state and product offering.
70	Identify a proposed administrative fee that you will pay to Sourcewell for facilitating, managing, and promoting the Sourcewell Contract in the event that you are awarded a Contract. This fee is typically calculated as a percentage of Vendor's sales under the Contract or as a per-unit fee; it is not a line-item addition to the Member's cost of goods. (See the RFP and template Contract for additional details.)	Lexipol agrees to award Sourcewell a 2% administrative fee in exchange for Sourcewell facilitating the resulting contracts.

Table 14A: Depth and Breadth of Offered Equipment Products and Services

Line Item	Question	Response *
71	Provide a detailed description of the equipment, products, and services that you are offering in your proposal.	<p>Products and Services</p> <p>Lexipol Learning Management System (LMS) Lexipol's Online Learning academies, FireRescue1 Academy, PoliceOne Academy, EMS1 Academy, CorrectionsOne Academy and LocalGovU, optimize the training experience for organizations of any size. The solution combines online learning content, training workflow, tracking, and reporting features. The full spectrum of training needs is covered in one platform. Each academy includes the world's largest library for public service professionals.</p> <p>ANNUAL SUBSCRIPTION SERVICE The following products are offered on an annual basis and are included in an annual subscription.</p> <ul style="list-style-type: none"> • Complete Pre-built Learning Plans ~ Auto Assignments • Custom Course Building Tool • External Training Tracker • Credential tracking • ISO Tracking • Notification Manager • Training Calendar • Report Builder • Content Library <p>Complete Pre-Built Learning Plans ~ Auto Assignments Our platform offers the capability to schedule online training and align it with internal training calendars and control access to online courses and material. Whether it's a simple assignment with one course or a learning plan of dozens of courses – administrators and instructors can easily track progress and activity. Both the assignment dashboard and reports features provide various filters to manage assignments, including assignment name, progress percentage, progress status, or training start or end dates. Member admins can schedule assignment release dates and due dates based on specific dates or in alignment with credential renewal timelines.</p> <p>Custom Course Building Tool Upload and build your own agency-specific content, including tests, to assign to personnel. Six templates are available to assist in organization of course assets and creation including single video course, external training course, SCORM course (using third-party authoring tools), full length course (standard one-hour courses) or training blocks. Your department can upload an unlimited quantity of custom videos or content, including lesson plans, PowerPoints, Policies, PDF files, Word.doc files, and other documents. Options to create pre-assessment and post- assessment knowledge-based quizzes and exams are available and easy-to-use drag and drop functionality allows users to quickly edit content modules as needed.</p> <p>External Training Tracker Track every activity completed at the organization using the Record External training</p>

module. Organizations can create a blended learning program which reflects all training per personnel in a comprehensive transcript by documenting drill-yard events, hands-on training, and more.

Credential tracking

Manage and track credential renewal by level, state, and category (EMT, paramedic, NREMT, etc.). Add category level requirements for credentials where applicable.

ISO Tracking

All FireRescue1 Academy courses have been categorized for ISO to display in the available reports and pre-build templates for Driver, Officer and Firefighter are available in the platform. Departments can also use the Custom Course builder to track hands-on activities for company, driver, officer, hazardous materials, and facilities training completed offline. Various levels of reporting are available based on the level of information an Administrator would like to review and are structured in a way to make ISO audits simple.

Notification Manager

The Academy features a robust notification manager that allows for action-based notifications, pre-scheduled notifications, recurring notifications, and other notifications that can be targeted to specific groups, organizations, and job titles. Notifications can be configured for assignments, credentials, and reports as needed.

Training Calendar

A centralized training calendar exists in both the student and administrator view to visually manage several features by date, including assignments, credentials, training events and more.

Report Builder

The platform features a robust reporting tool for creation of recurring or on-demand reports for tracking compliance of personnel assignments and credentials.

Administrators can pull reports for members, groups, courses, can export training records based on rank, division, shift, course, policy, assignment, or credential.

Content Library

Each of the learning sites hosts a library of hundreds of full-length courses written to laws, guides, and standards that apply to the perspective profession. Some of the standards are NFPA, CAPCE, National Registry, POST, and many more. The courses cover many topics such as basic skills, special operations, officer training, safety, HR compliance, etc. Where applicable Lexipol seeks to get continuing education approvals for content to assist with certification renewals.

Site Customization

Individual organizational branding and workflow is important to the success of a training program. At contract execution, Lexipol will work with the organization to customize the site to their needs. These customizations include:

- Department Home Page
- Members, Roles, Groups
- Customizable Settings

Department Home Page

Within the platform, your department will have a custom homepage with preferred logo or patch, custom bulletin messaging environment with a rich text editor to share important information and display of featured courses.

Members, Roles, Groups

Each user will have a unique profile in the LMS, notating their email, username, department or POST ID, position, and groups in the system. Within their dashboard, members can easily see which courses are assigned to them, manage their credentials, and download certificates of completion. Administrators can adjust each member's access by assigning roles as needed.

The Academy platform comes pre-built with five different roles with various levels of administrative functionality. These roles allow your agency to manage your personnel's access on the platform seamlessly, letting them see and access only what they need to. Custom roles are available upon request.

Easily build and manage custom groups for your personnel, dividing them by certification level, rank, shift or other tailored options.

Customizable Settings

From the Admin control panel, organizations can control which content personnel can view, if they are shown correct answers to knowledge checkpoint quizzes, as well as designate the number of attempts and minimum score for quizzes and tests.

LEXIPOL ORGANIZATIONAL POLICIES & TRAINING

An integral part of establishing a clear training and career success plan that will meet an organization's strategic/operational goals and expectations is a constantly updated policy manual that becomes the playbook for success. Having a playbook based on Federal/State laws and regulations, industry standards, nationwide best

practices, and court decisions which is constantly updated by attorneys that specialize in government industries (fire, law enforcement, EMS, dispatch, corrections, probation, and human resources) and supported by daily training is a challenge for all organizations small and large. Lexipol comes in to work with the organization to tackle these challenges and reduce risk for the organization and its members by increasing knowledge and retention. Lexipol provides this through an annual subscription and recommended implementation.

Lexipol starts with a policy and procedure solution that provides a legally defensible, constantly updated manual that outlines the expectations upon which career training will be based. This is available anytime to members through web and app-based platforms compatible with most electronic devices. Once the policy and procedure manuals are reflective of up-to-date requirements and organizational goals, those expectations are then applied in scenario-based training, that is developed and provided, on the organizations policies and procedures resulting in increased operational consistency and confidence in the discharge of the duties and tasks outlined.

ANNUAL SUBSCRIPTION SERVICE

The following products are offered on an annual basis. The appropriate components for the organization are identified through the sales process and full pricing is disclosed prior to contract execution.

- Policy/Procedure Manuals & Updates
- Daily Training Bulletins
- Web Based and Mobile App Delivery Platform
- Reports
- Supplemental Publication Service
- Platform as a Service
- Accreditation Workbench

Policy/Procedure Manuals & Updates

Constitutionally based, constantly updated policies are the foundation for consistent organizational operations and are key to lowering liability and risk. Lexipol's comprehensive policy manual covers all aspects of an organization's operations to include outlining the areas in which training should be focused. The provided policies were researched and written by attorneys, specializing in public safety and local government, and subject matter experts. They are based on Federal/State laws and regulations as well as nationwide best practices with the ability for the organization to customize the content to reflect existing terminology, structure, and operations.

Clear and accessible procedures are imperative to ensure safe, effective, and consistent personnel interactions and emergency response. Lexipol's procedures, based on national best practices, give the organization critical operational and administrative procedures as well as a template to build on. They address the operations most often cited as contributing to injury or death as well as the most common call types. In addition to operations, there are administrative procedures that address the areas of highest legal liability as well as best practices for organizational success. Lexipol's procedures are designed to support safe and effective operations in fire and law enforcement.

Having up-to-date manuals in place creates a need for constant update. Lexipol's legal and content development teams continuously review Federal/State laws and regulations, industry standards, court decisions, and evolving nationwide best practices. When needed, we create new or update current policies and provide them to the organization making it simple and efficient to keep their policy content up to date. The updates are delivered through Lexipol's web-based content delivery platform.

Daily Training Bulletins (DTBs)

Lexipol's Daily Training Bulletins are designed to help personnel learn and apply the organization's policy and procedure, if applicable, content through multiple 2-minute, scenario-based training exercises. The scenarios written by people actively employed in the various local government industries to ensure that relevance and appropriate guidance is provided. The exercise provides guidance through an analysis and conclusion, that are included, which walks the with the members hand-in-hand on how to practically apply policy and procedure thereby allowing for increased operational consistency as well as confidence in all levels of responsibility in the organization.

The Daily Training Bulletins also ensure understanding and retention of policy and procedure content by a singular focus on one aspect of the policy or procedure at a time with the potential for repetition under different scenarios. Each bulletin also concludes with a question that the user understood the training objective and application discussed.

The organization may assign or customize and assign the bulletins provided or create their own. The bulletins are complete and ready for assignment once issued to the organization which saves time and money on policy/procedure training development. The ability to customize gives the organization the ability to alter the scenario to reflect a recent occurrence to make it more relevant. The organization can also create their own bulletins to supplement training on local specific content or to enhance what is being provided to focus on a local occurrence that may not be covered in the provided training.

Web-Based Delivery Platform and Mobile App (Knowledge Management System) Lexipol's online content delivery platform, called the Knowledge Management System (KMS), provides secure storage and easy access to all the policy/procedure content, and facilitates staff access to policies and training completion. The KMS is accessible via apps for Android and IOS and is compatible on Windows and Mac. The compatibility allows for 24/7 access over almost any electronic device the organization or individual possesses. (Smartphones, tablets, desktop computers, MDT's, etc.) The system allows for in-the-field access to the information not only operations but reference and continued training by always having the most current version of policies/procedures available.

KMS tracks acknowledgements of new policies read, as well as any revisions to existing policies, and completions of the daily training bulletins. This creates a database to assist the organization in creating more goal focused training to help increase operational effectiveness.

The system also archives the Lexipol information, as well as the organization's custom content, that is changed or revised thereby allowing for the training and differentiation of the old version versus the new. The archive also allows the organization to be able to access the information anytime in the future as the need arises.

Reports

Lexipol's KMS provides intuitive reporting capabilities and easy-to-read reports that enhance staff meetings as well as strategic planning for organizational training and goals. The database can be accessed to create and sort reports by multiple parameters to include employee, acknowledgements, policy, procedure, other subgroups (e.g., shift, assignment, etc.), and completion of Daily Training Bulletins by agency member and/or topic. These parameters can also be combined to create fewer more efficient reports. This reduces time supervisors spend verifying policy acknowledgement and training completion while increasing accountability by showing who has not completed assignments. The reports also assist the organization by easily capturing the data in formats that can be stand-alone or compatible with other platforms to merge into other reports.

Supplemental Publication Service

Lexipol's Supplemental Publication Service (SPS) organizes the storage of the organization's specific content giving one place to access protocols, procedures, guidelines, general orders, training guides, career path training plans or secondary policy manuals. SPS also electronically links department-specific procedural or supplemental content to the Lexipol state master policy manual. If the organization is fire or law enforcement, the Lexipol provided procedures are stored in a SPS to clearly delineate what is policy and what is procedure. Organizations can purchase more than one SPS depending on their needs, and it is included in the annual subscription.

Accreditation Workbench

Managing the organizations accreditation process is a complex task that requires intimate knowledge of policy, training, and extreme attention to detail. Lexipol's Accreditation Workbench provides an organization's Accreditation Manager access to content and tools that significantly reduce the time and effort required to successfully prepare for and execute an accreditation assessment. The workbench has current standards for supported accreditation programs preloaded and viewable. Lexipol policies are pre-tagged to many applicable standards and the Accreditation Manager can easily add or modify tagging to meet specific program needs. Compliance checklists are preloaded for each standard, clearly detailing required written directives and proofs of compliance (Accreditation Manager can also customize the checklists). The organization can upload, store, and organize proofs of compliance (e.g., documents, videos) in a preformatted electronic folder system that is based on how the accrediting body organizes standards and its accreditation review cycle. It also allows for complete self-assessments by using analysis tools to identify gaps in required proofs of compliance. The workbench streamlines the assessment process by generating printed reports or showing the assessor compliance items stored in the online system.

IMPLEMENTATION SERVICE

A recommended one-time cost that is a service to assist policy manual creation and it accompanies the annual subscription. We work hand in hand with the organization to meet their unique needs, philosophy, and project timeline providing start to finish comprehensive policy adoption assistance. Implementation can also be customized to meet organizational needs. The following are included in the implementation services:

- Organizational Policy Cross Reference
- Content Extraction
- Collaborative Tiered or Full Implementation

Policy Cross Reference

Making the transition to Lexipol starts with understanding how an organization's current policy content compares with Lexipol's master policy content. Our policy cross reference service provides a logical method to distinguishing between the two. The service includes an analysis of existing policies and procedures to identify content similar to Lexipol's master content, as well as content unique to the organizations jurisdiction and not covered within the Lexipol manual. Existing submitted policies are returned with annotations and tips on how to integrate into the Lexipol master content. There is also a one-on-one review with the organization to discuss the cross-reference report. There are three cross references available depending on organizational needs. They are as follows:

- Standard Cross Reference
- Comprehensive Cross Reference
- Accreditation Cross Reference

Agency-Specific Content Extraction

This service is perfect for organizations that wish to populate one or more Supplemental Publication Service (SPS) manuals with their existing content. Lexipol will do the heavy lifting of incorporating their supplemental content (procedures, guidelines, general orders, training guide or a secondary policy manual) into the SPS. Access to an electronic copy of the existing content and a subscription to the Supplemental Publication Service (SPS) is required.

Included in content extraction is data entry of organizational procedures or supplemental content into Lexipol's Knowledge Management System (KMS). Note: Lexipol reserves the right to limit the amount of content being imported into the SPS. Professional Services will assist in deconflicting the information in the SPS with the policy manual and create hyperlinks to information within the platform to ease user access. This ensures consistent, professional formatting for organization's policy-related content and provides the ability to hyperlink related content for enhanced end-user experience.

Tiered Implementation

Benefit from our proven, systematic approach to implementing policies. The organization will receive one-on-one collaborative assistance to help review, customize and adopt the policies efficiently and effectively.

- Tier 1: High-Risk Policies

Tier 1 represents about 20% of the manual, including foundational policies necessary to provide structure and authority to your policy manual, as well as policies addressing high-risk, low-frequency and high-risk, high-frequency incidents.

- Tier 2: High-Liability Policies

Tier 2 represents about 20% of the manual, including policies that relate to common day-to-day calls for service that have a higher level of potential liability.

- Tier 3: Daily Operations Policies

Tier 3 represents about 20% of the manual, including policies needed for orderly daily operations of your organization.

- Tier 4: Defensibility Policies

Tier 4 represents about 20% of the manual, including policies essential to agency and agency member defensibility, including civil liability-related topics.

- Tier 5: Operational Consistency Policies

Tier 5 represents about 20% of the manual, including policies needed to ensure operational consistency across your organization.

Full Implementation

Lexipol's Full Implementation Service is individually tailored for agencies who want to start-to-finish, comprehensive policy adoption assistance. Lexipol's experienced Professional Services staff will streamline the process of policy adoption by assisting the organization in developing a policy manual that meets their unique needs, philosophy, and project timeline. They will integrate pre-existing agency content into appropriate sections within the policy manual using a proven structure of policy editing and content merging to create the organizations new policy manual thereby saving the organization countless hours and dollars. This will provide a framework to expedite subsequent policy updates and Daily Training Bulletin administration.

		<p>Full implementation includes start-to-finish comprehensive policy adoption assistance, Policy Cross Reference, and Content Extraction.</p> <p>DELIVERED AND OPERATIONAL</p> <p>Lexipol Policy SaaS applications are multitenant and user/agency data is separated logically via RBAC. Database Infrastructure is encrypted at rest via AES-256 and application traffic is encrypted with TLS1.1 or above.</p> <p>Lexipol Policy SaaS applications are backed by a dedicated, off-site, cross-region Disaster Recovery Datacenter. Backups of all SaaS systems are continuously synchronized to the Disaster Recovery Datacenter and tested via automated means; manual testing is performed regularly. Disaster Recovery and System Restoration policies/procedures are documented, communicated, and tested regularly. Access to the system is granted upon execution of the sales agreement.</p>	
72	Within this RFP category there may be subcategories of solutions. List subcategory titles that best describe your products and services.	Public Safety, Administrative Services, Office & Technology	*

Table 14B: Depth and Breadth of Offered Equipment Products and Services

Indicate below if the listed types or classes of equipment, products, and services are offered within your proposal. Provide additional comments in the text box provided, as necessary.

Line Item	Category or Type	Offered *	Comments
73	Facilities, structures (fixed or mobile), equipment, props, supplies, and consumables.	<input type="radio"/> Yes <input checked="" type="radio"/> No	
74	Augmented or virtual reality, interactive, and digital simulation technology and related software, hardware, or equipment.	<input checked="" type="radio"/> Yes <input type="radio"/> No	Lexipol provides interactive training courses through a proprietary web based platform available 24/7 on computer and mobile devices where connectivity is available.
75	Instructional, educational, and training programs or systems with related materials and supplies.	<input checked="" type="radio"/> Yes <input type="radio"/> No	We provide a full-service LMS with electronic reporting, tracking and training management, including the ability to upload and assign agency-specific training content, more than 3,300 high-quality accredited training courses and microlearning videos, and 24/7 accessibility from any internet-enabled device. Lexipol adheres to industry standards and state and federal law when creating online learning and policy training content.
76	Services related to the offering of the solutions described in RFP Sections 1. a. – c., including design, installation, maintenance, repair, training, integration, support, and customization.	<input checked="" type="radio"/> Yes <input type="radio"/> No	Each agency begins their journey with platform training and organizational customization conducted by Lexipol's Professional Service Implementation team. Ongoing training, support and customization is handled by our customer success team.

Table 15: Industry Specific Questions

Line Item	Question	Response *
77	Describe your products/services interoperability with other public safety equipment, software and systems, if applicable.	Our online learning platform integrates with human resources information system (HRIS), records management platform, and scheduling software to streamline training management. We offer Single Sign-on to control LMS access permissions with the agency's identity management system and sync HR information like employee rank, job title, education and professional experience. Lexipol's online learning and policy training solution generate reports in formats accepted by most major software systems. Policy training content can be exported to PDF format or Excel spreadsheet then uploaded for distribution and accreditation reporting purposes.
78	Describe your strategy related to implementation, use of installation partners and integration with other training products and systems if applicable.	Every department and agency will participate in an onboarding process conducted by Lexipol's Professional Service Implementation team. This group of passionate professionals focuses on product implementation, initial training on the platform features, technical support and reporting.
79	Explain your licensing process and service agreements with end users.	Services agreements are renewed on an annual basis unless otherwise noted in the agreement. The start of the subscription is based on the date the agreement is executed unless otherwise noted.
80	Describe compliance to applicable national standards such as: National Fire Protection Association (NFPA), Occupational Safety and Health Administration (OSHA), and American National Standards Institute (ANSI).	All content is constitutionally sound and based on Federal/State laws and regulations, NFPA, OSHA, NIOSH, court decisions, and current industry best practices.
81	Explain and provide information about any design services you provide if applicable.	N/A

Table 16: Exceptions to Terms, Conditions, or Specifications Form

Line Item 82. NOTICE: To identify any exception, or to request any modification, to the Sourcwell template Contract terms, conditions, or specifications, a Proposer must submit the exception or requested modification on the **Exceptions to Terms, Conditions, or Specifications Form** immediately below. The contract section, the specific text addressed by the exception or requested modification, and the proposed modification must be identified in detail. Proposer's exceptions and proposed modifications are subject to review and approval of Sourcwell and will not automatically be included in the contract.

Contract Section	Term, Condition, or Specification	Exception or Proposed Modification

Documents

Ensure your submission document(s) conforms to the following:

1. Documents in PDF format are preferred. Documents in Word, Excel, or compatible formats may also be provided.
2. Documents should NOT have a security password, as Sourcwell may not be able to open the file. It is your sole responsibility to ensure that the uploaded document(s) are not either defective, corrupted or blank and that the documents can be opened and viewed by Sourcwell.
3. Sourcwell may reject any response where any document(s) cannot be opened and viewed by Sourcwell.
4. If you need to upload more than one (1) document for a single item, you should combine the documents into one zipped file. If the zipped file contains more than one (1) document, ensure each document is named, in relation to the submission format item responding to. For example, if responding to the Marketing Plan category save the document as "Marketing Plan."

- [Pricing](#) - 2022 Pricing for Sourcewell.xlsx - Saturday January 15, 2022 15:24:27
- [Financial Strength and Stability](#) - Financial Strength & Stability.pdf - Tuesday January 18, 2022 08:18:53
- [Marketing Plan/Samples](#) - Marketing Plan.pdf - Tuesday January 18, 2022 04:43:09
- WMBE/MBE/SBE or Related Certificates (optional)
- [Warranty Information](#) - Warranty.pdf - Tuesday January 18, 2022 04:54:28
- [Standard Transaction Document Samples](#) - Sample Sales Agreement.pdf - Tuesday January 18, 2022 12:36:19
- Upload Additional Document (optional)

Addenda, Terms and Conditions

PROPOSER AFFIDAVIT AND ASSURANCE OF COMPLIANCE

I certify that I am the authorized representative of the Proposer submitting the foregoing Proposal with the legal authority to bind the Proposer to this Affidavit and Assurance of Compliance:

1. The Proposer is submitting this Proposal under its full and complete legal name, and the Proposer legally exists in good standing in the jurisdiction of its residence.
2. The Proposer warrants that the information provided in this Proposal is true, correct, and reliable for purposes of evaluation for contract award.
3. The Proposer, including any person assisting with the creation of this Proposal, has arrived at this Proposal independently and the Proposal has been created without colluding with any other person, company, or parties that have or will submit a proposal under this solicitation; and the Proposal has in all respects been created fairly without any fraud or dishonesty. The Proposer has not directly or indirectly entered into any agreement or arrangement with any person or business in an effort to influence any part of this solicitation or operations of a resulting contract; and the Proposer has not taken any action in restraint of free trade or competitiveness in connection with this solicitation. Additionally, if Proposer has worked with a consultant on the Proposal, the consultant (an individual or a company) has not assisted any other entity that has submitted or will submit a proposal for this solicitation.
4. To the best of its knowledge and belief, and except as otherwise disclosed in the Proposal, there are no relevant facts or circumstances which could give rise to an organizational conflict of interest. An organizational conflict of interest exists when a vendor has an unfair competitive advantage or the vendor's objectivity in performing the contract is, or might be, impaired.
5. The contents of the Proposal have not been communicated by the Proposer or its employees or agents to any person not an employee or legally authorized agent of the Proposer and will not be communicated to any such persons prior to Due Date of this solicitation.
6. If awarded a contract, the Proposer will provide to Sourcewell Participating Entities the equipment, products, and services in accordance with the terms, conditions, and scope of a resulting contract.
7. The Proposer possesses, or will possess before delivering any equipment, products, or services, all applicable licenses or certifications necessary to deliver such equipment, products, or services under any resulting contract.
8. The Proposer agrees to deliver equipment, products, and services through valid contracts, purchase orders, or means that are acceptable to Sourcewell Members. Unless otherwise agreed to, the Proposer must provide only new and first-quality products and related services to Sourcewell Members under an awarded Contract.
9. The Proposer will comply with all applicable provisions of federal, state, and local laws, regulations, rules, and orders.
10. The Proposer understands that Sourcewell will reject RFP proposals that are marked "confidential" (or "nonpublic," etc.), either substantially or in their entirety. Under Minnesota Statutes Section 13.591, subdivision 4, all proposals are considered nonpublic data until the evaluation is complete and a Contract is awarded. At that point, proposals become public data. Minnesota Statutes Section 13.37 permits only certain narrowly defined data to be considered a "trade secret," and thus nonpublic data under Minnesota's Data Practices Act.
11. Proposer its employees, agents, and subcontractors are not:
 1. Included on the "Specially Designated Nationals and Blocked Persons" list maintained by the Office of Foreign Assets Control of the United States Department of the Treasury found at: <https://www.treasury.gov/ofac/downloads/sdnlist.pdf>;
 2. Included on the government-wide exclusions lists in the United States System for Award Management found at: <https://sam.gov/SAM/>; or
 3. Presently debarred, suspended, proposed for debarment, declared ineligible, or voluntarily excluded from programs operated

by the State of Minnesota; the United States federal government or the Canadian government, as applicable; or any Participating Entity. Vendor certifies and warrants that neither it nor its principals have been convicted of a criminal offense related to the subject matter of this solicitation.

By checking this box I acknowledge that I am bound by the terms of the Proposer's Affidavit, have the legal authority to submit this Proposal on behalf of the Proposer, and that this electronic acknowledgment has the same legal effect, validity, and enforceability as if I had hand signed the Proposal. This signature will not be denied such legal effect, validity, or enforceability solely because an electronic signature or electronic record was used in its formation. - Jeff Oathout, Director of Sales , Lexipol, LLC

The Proposer declares that there is an actual or potential Conflict of Interest relating to the preparation of its submission, and/or the Proposer foresees an actual or potential Conflict of Interest in performing the contractual obligations contemplated in the bid.

Yes No

The Bidder acknowledges and agrees that the addendum/addenda below form part of the Bid Document.

Check the box in the column "**I have reviewed this addendum**" below to acknowledge each of the addenda.

File Name	I have reviewed the below addendum and attachments (if applicable)	Pages
Addendum_1_PS_Training_Simulation_Eqpt_Tech_RFP_011822 Tue December 14 2021 07:23 AM	<input checked="" type="checkbox"/>	2



MASTER SERVICE AGREEMENT

Agency's Name: Arcadia Fire Department (CA)
Agency's Address: 710 S Santa Anita Ave
Arcadia, California 91006

Agency's Sourcewell Member ID: 93725

Attention: Chief Chen Suen

Sales Rep: Ray Shanahan
Lexipol's Address: 2611 Internet Boulevard, Suite 100
Frisco, Texas 75034

Effective Date: _____
(to be completed by Lexipol upon receipt of signed Agreement)

This Master Service Agreement (the "Agreement") is entered into by and between Lexipol, LLC, a Delaware limited liability company ("Lexipol"), and the department, entity, or organization referenced above ("Agency"). This Agreement consists of:

- (a) this **Cover Sheet**
- (b) **Exhibit A** - Selected Services and Associated Fees
- (c) **Exhibit B** - Terms and Conditions of Service

This Agreement is entered into subject to the terms and conditions contained in **Sourcewell Contract Number 011822-LXP (the Sourcewell Contract)**. In the event of any conflict between the terms and conditions of this Agreement and the terms and conditions set forth in the Sourcewell Contract, the terms and conditions of the Sourcewell Contract shall control.

Each individual signing below represents and warrants that they have full and complete authority to bind the party on whose behalf they are signing to all terms and conditions contained in this Agreement.

Arcadia Fire Department (CA)

Signature: _____

Print Name: _____

Title: _____

Date Signed: _____

Lexipol, LLC

Signature: _____

Print Name: _____

Title: _____

Date Signed: _____

Exhibit A

SELECTED SERVICES AND ASSOCIATED FEES

Agency is purchasing the following:

Prorated phase 1 start

QTY	DESCRIPTION	UNIT PRICE	SOURCEWELL DISC	DISC AMT	EXTENDED
1	Annual Fire Policy Phase 1 Manual & Daily Training Bulletins w/Supplemental Publication Service w/Fire Operations Procedures (Start: 5/1/2024 End: 6/30/2024)	USD 1,358.17	10%	USD 135.82	USD 1,222.35
Subscription Line Items Total				USD 135.82	USD 1,222.35
1	Fire Agency-Specific Content Extraction	USD 4,070.00	10%	USD 407.00	USD 3,663.00
One-Time Line Items Total				USD 407.00	USD 3,663.00
				USD 542.82	USD 4,885.35
Prorated phase 1 start Sourcewell Discount:					USD 542.82
Prorated phase 1 start TOTAL:					USD 4,885.35

Annual Fire Policy subscription

QTY	DESCRIPTION	UNIT PRICE	SOURCEWELL DISC	DISC AMT	EXTENDED
1	Annual Fire Policy Manual & Daily Training Bulletins w/Supplemental Publication Service w/Fire Operations Procedures (Start: 7/1/2024 End: 6/30/2025)	USD 13,546.00	10%	USD 1,354.60	USD 12,191.40
Subscription Line Items Total				USD 1,354.60	USD 12,191.40
				USD 1,354.60	USD 12,191.40
Annual Fire Policy subscription Sourcewell Discount:					USD 1,354.60
Annual Fire Policy subscription TOTAL:					USD 12,191.40

Full Fire Implementation

QTY	DESCRIPTION	UNIT PRICE	SOURCEWELL DISC	DISC AMT	EXTENDED
1	Fire Full Implementation	USD 25,715.00	10%	USD 2,571.50	USD 23,143.50
One-Time Line Items Total				USD 2,571.50	USD 23,143.50
				USD 2,571.50	USD 23,143.50
Full Fire Implementation Sourcewell Discount:					USD 2,571.50
Full Fire Implementation TOTAL:					USD 23,143.50

*Fire pricing is based on 54 Fire Authorized Staff.

Initial Term

Initial Phase 1 prorated start followed by standard 12 month agreement

The foregoing pricing has been prorated for the benefit of Agency and Agency therefore agrees that they will waive the right to cancel this agreement until the end of the first renewal period.

Discount Notes

10% Sourcewell

Notes

Prorated Phase 1 start plus 12 month Annual subscription to be billed in May 2024 to meet the agency's needs.

Total term of the agreement is May 1, 2024 - June 30, 2025

Full Fire Implementation to be billed after July 1, 2024

Exhibit B
Terms and Conditions of Service

These Terms and Conditions of Service (the “Terms”) govern the rights and obligations of Lexipol and Agency under this Agreement. Lexipol and Agency may each be referred to herein as a “Party” and collectively as the “Parties.”

1. Definitions. Each of the following capitalized terms will have the meaning included in this Section. Other capitalized terms are defined within their respective sections, below.

1.1 “Agency” means the department, agency, office, organization, company, or other entity purchasing and/or subscribing to Lexipol Services, as may be further denoted on the cover sheet to which these Terms are attached.

1.2 “Agency Data” means all data, information, and content owned by Agency prior to the Effective Date, or which Agency provides during the Term of this Agreement for purposes of identifying authorized users, confirming departmental information, or which are ancillary to receipt of Lexipol Services.

1.3 “Agreement” means the combination of the cover sheet (signature page); Exhibit A (“Selected Services and Associated Fees”); this Exhibit B; and any other documents attached hereto and expressly incorporated herein by reference.

1.4 “Effective Date” means the date specified on the cover sheet (signature page), or as otherwise expressly set forth and agreed upon by Lexipol and Agency in writing and defined as the “Effective Date.”

1.5 “Initial Term” means the period commencing on the Effective Date and continuing for the length of time indicated on Exhibit A. If not so indicated, the default Initial Term is one (1) year from the Effective Date.

1.6 “Lexipol Content” means all content in any format including but not limited to written content, images, videos, data, information, and software multimedia provided by Lexipol and/or its licensors via the Services.

1.7 “Services” means all products and services, including but not limited to all software subscriptions, content licensing, professional services, and ancillary support services as may be offered by Lexipol and/or its affiliates from time to time.

2. Term; Renewal. This Agreement becomes enforceable upon signature by Agency’s authorized representative, with an Effective Date as indicated on the cover page. This Agreement shall renew in successive one-year periods (each, a “Renewal Term”) on the anniversary of the Effective Date unless terminated as set forth herein. The Initial Term and all Renewal Terms collectively comprise the “Term” of this Agreement.

3. Termination.

3.1 For Convenience; Non-Appropriation. This Agreement may be terminated by Agency at any time for convenience (including due to lack of appropriation of funds) by providing written notice to Lexipol.¹

3.2 For Cause. This Agreement may be terminated by either party, effective immediately, (a) in the event the other party fails to discharge any obligation, including payment obligations, or remedy any default hereunder for a period of more than thirty (30) calendar days after it has been provided written notice of such failure or default; or (b) in the event that the other party makes an assignment for the benefit of creditors or commences or has commenced against it any proceeding in bankruptcy, insolvency or reorganization pursuant to the bankruptcy laws of any applicable jurisdiction.

3.3 Effect of Expiration or Termination. Upon the expiration or termination of this Agreement for any reason, Agency’s access to the Services ordered pursuant to Exhibit A herein shall cease unless Lexipol has, in its sole discretion, provided for their limited continuation. Termination or expiration of this Agreement shall not, however, relieve either party from any obligation or liability that has accrued under this Agreement prior to the date of such termination or expiration, including payment obligations.

¹ Note: fees paid for Online Services (as defined herein) are not eligible for refund, proration, or offset in the event of Agency’s termination for convenience as Online Services are delivered in full as of the Effective Date. Fees pre-paid for Professional Services may be eligible for offset to the extent such Services have not been delivered by Lexipol to Agency.

4. Fees; Invoicing. Lexipol will invoice Agency at the commencement of the Initial Term and thirty (30) days prior to the commencement of each Renewal Term, if applicable. Agency agrees to remit payment within thirty (30) calendar days of receipt of Lexipol's invoice. Payments may be made electronically through Lexipol's online customer portal or by mailing a check to Lexipol at 2611 Internet Blvd, Ste. 100, Frisco, TX 75034 (Attn: Accounts Receivable). Agency is responsible for all third-party fees (e.g., wire fees, bank fees, credit card processing fees) incurred when paying electronically, and such fees are in addition to those listed on Exhibit A. Lexipol reserves the right to increase fees for Renewal Terms following notice to Agency. All fee amounts stated in Exhibit A are exclusive of taxes. Unless otherwise exempt, Agency is responsible for and will pay in full all taxes related to receipt of Lexipol's Services. If Agency is exempt, it must send its exemption certificate(s) to taxes@lexipol.com.

5. Terms of Service. The following provisions govern access to and use of specific Lexipol's Services:

5.1 Online Services. Lexipol's Online Services include all online services offered by Lexipol and its partners, affiliates, and licensors. Online Services include, without limitation, Lexipol's Policy Knowledge Management System ("KMS"), Learning Management System ("LMS")², Cordico wellness application(s), GrantFinder, and Virtual Instructor-Led Training (collectively, the "Online Services").

5.2 Professional Services. Lexipol's Professional Services include certain paid Services that are not part of Lexipol's Online Services and which require the professional expertise of Lexipol personnel and/or contractors, including implementation support for policy manuals, technical support for online learning, accreditation consulting, grant writing³, and projects requiring regular input from Lexipol's subject matter experts (collectively, "Professional Services"). Professional Services may also be referred to as "One-Time" Services on Exhibit A.

5.3 Intellectual Property. Lexipol's Services, and the Lexipol Content underlying such Services, are proprietary and, where applicable, protected under U.S. copyright, trademark, patent, and/or other applicable laws. By subscribing to Lexipol's Online Services, Agency and its personnel receive a personal, limited, non-sublicensable and non-assignable license to access and use such Services in conformity with these Terms. Nothing contained in this Agreement, and no course of dealing, shall be construed as conferring any right of ownership to Lexipol's Services or Lexipol Content. Lexipol's policy Content may be incorporated into Agency's final policies⁴, including beyond the expiration or termination of this Agreement, but Agency may not create other Derivative Works, share Lexipol Content with third parties, or commercialize Lexipol Content in any way. As used herein, other "Derivative Works" include any work product based on or which incorporates Lexipol Content, including any revision, modification, abridgement, condensation, expansion, compilation, or any other form in which Lexipol Content, or any portion thereof, is recast, transformed, or adapted. Agency acknowledges and agrees that Lexipol shall have no responsibility to update the Lexipol Content used by Agency beyond the Term of this Agreement and that Lexipol shall have no liability for Agency's creation or use of Derivative Works.

5.4 Account Security. Access to Lexipol's Services is personal and unique to Agency. Agency shall not assign, transfer, or provide access to Lexipol Services to any third party without Lexipol's prior written consent. Agency is responsible for maintaining the security and confidentiality of Agency's usernames and passwords and the security of Agency's accounts. Agency will immediately notify Lexipol if Agency becomes aware that any person or entity other than authorized Agency personnel has used Agency's account or Agency's usernames and/or passwords.

5.5 Agency Data. Lexipol's use of Agency Data is limited to providing the Services, retaining records in the regular course of business, and complying with valid legal obligations. Lexipol will use commercially reasonable efforts to ensure the security of all Agency Data. Lexipol's Services use the Secure Socket Layer (SSL) protocol, which encrypts information as it travels between Lexipol and Agency. However, data transmission on the internet is not always 100% secure and Lexipol cannot and does not warrant that information Agency transmits to or through Lexipol or the Services is 100% secure.

² LMS Services include, but are not limited to: PoliceOne Academy, FireRescue1 Academy, EMS1 Academy, Corrections1 Academy, and LocalGovU.

³ Agency is responsible for submitting all information reasonably required by Lexipol's grant writing team in a timely manner and always at least five (5) days prior to each grant application submission date. Agency is responsible submissions of final grant applications by grant deadlines. Failure to timely submit required materials to Lexipol's grant writing team will result in rollover of project fees to next grant application cycle, not a refund of fees. Requests for cancellation of grant writing services which have already begun will result in a 50% fee of the total value of the service.

⁴ NOTE: AGENCY ACKNOWLEDGES AND AGREES THAT, PRIOR TO USE OR FINAL PUBLICATION BY AGENCY, ALL AGENCY POLICIES AND DAILY TRAINING BULLETINS (DTBs) HAVE BEEN INDIVIDUALLY REVIEWED AND ADOPTED BY AGENCY. AGENCY ACKNOWLEDGES AND AGREES THAT IT, AND NOT LEXIPOL, WILL BE CONSIDERED THE "POLICY MAKER" WITH REGARD TO EACH AND EVERY SUCH POLICY AND DTB.

6. **Confidentiality.** Each Party may disclose information to the other Party that would be reasonably considered confidential, including Agency Data (collectively, "Confidential Information"). The receiving Party will: (a) limit disclosure of any such Confidential Information to authorized representatives; (b) advise its personnel and agents of the confidential nature of the Confidential Information and of the obligations set forth in this Agreement; and (c) not disclose any Confidential Information to any third party unless expressly authorized by the disclosing Party. Each Party may disclose Confidential Information pursuant to a valid governmental, judicial, or administrative order, subpoena, regulatory request, or equivalent, provided that the disclosing Party promptly notifies, to the extent practicable, the other Party prior to such disclosure so that the other party may seek to make such disclosure subject to a protective order or other appropriate remedy to preserve the confidentiality of the Confidential Information.

7. **Warranty.** LEXIPOL WARRANTS THAT ITS SERVICES SHALL NOT INFRINGE THE RIGHTS OR INTELLECTUAL PROPERTY OF OTHERS, ARE PROVIDED IN A PROFESSIONAL AND WORKMANLIKE MANNER IN ACCORDANCE WITH PREVAILING INDUSTRY STANDARDS, AND THAT THEY SHALL BE FIT FOR THE SPECIFIC PURPOSES SET FORTH HEREIN. NOTWITHSTANDING THE FOREGOING, LEXIPOL'S SERVICES ARE PROVIDED "AS-IS" AND LEXIPOL DISCLAIMS ALL OTHER WARRANTIES, EXPRESS, IMPLIED, OR OTHERWISE.

8. **Indemnification; Limitation of Liability.** Lexipol will indemnify, defend, and hold harmless Agency from and against any and all loss, liability, damage, claim, cost, charge, demand, fine, penalty, or expense arising directly and solely out of Lexipol's acts or omissions in providing the Services. Each Party's cumulative liability resulting from any claims, demands, or actions arising out of or relating to this Agreement shall not exceed the aggregate amount of fees paid by Agency to Lexipol during the twelve-month period immediately prior to the assertion of such claim, demand, or action. In no event shall either Party be liable for indirect, incidental, consequential, special, exemplary damages, or lost profits.

9. **General Terms.**

9.1 **Entire Agreement.** This Agreement embodies the entire agreement between the Parties and supersedes all prior agreements with respect to the subject matter hereof. No representation, promise, or statement of intention has been made by either party that is not embodied herein. Terms and conditions set forth in any purchase order or other document that are inconsistent with or in addition to the terms and conditions set forth in this Agreement are rejected in their entirety and void, regardless of when received, without further action. No amendment, modification, or supplement to this Agreement shall be binding unless it is made in writing and signed by both parties.

9.2 **General Interpretation.** The terms of this Agreement have been chosen by the parties hereto to express their mutual intent. This Agreement shall be construed equally against each party without regard to any presumption or rule requiring construction against the party who drafted this Agreement or any portion thereof.

9.3 **Invalidity of Provisions.** Each provision contained in this Agreement is distinct and severable. A declaration of invalidity or unenforceability of any provision or portion thereof shall not affect the validity or enforceability of any other provision. Should any provision or portion thereof be held to be invalid or unenforceable, the parties agree that the reviewing authority should endeavor to give effect to the parties' intention as reflected in such provision to the maximum extent possible.

9.4 **Governing Law.** Each party shall maintain compliance with all applicable laws, rules, regulations, and orders relating to its obligations pursuant to this Agreement. This Agreement shall be construed in accordance with, and governed by, the laws of the state in which Agency is located, without giving effect to any choice of law doctrine that would cause the law of any other jurisdiction to apply.

9.5 **Assignment.** This Agreement may not be assigned by either party without the prior written consent of the other. Notwithstanding the foregoing, this Agreement may be assumed by a party's successor in interest through merger, acquisition, or consolidation without additional notice or consent.

9.6 **Waiver.** Either party's failure to exercise, or delay in exercising, any right or remedy under any provision of this Agreement shall not constitute a waiver of such right or remedy.

9.7 **Notices.** Any notice required hereunder shall be in writing and shall be made by certified mail (postage prepaid) to known, authorized recipients at such address as each party may indicate from time to time. In addition, electronic mail (email) to established and authorized recipients is acceptable when acknowledged by the receiving party.



STAFF REPORT

Office of the City Clerk

DATE: May 7, 2024

TO: Honorable Mayor and City Council

FROM: Dominic Lazzaretto, City Manager
By: Linda Rodriguez, City Clerk

SUBJECT: RENEWAL OF THE WEED ABATEMENT SERVICES AGREEMENT BETWEEN THE CITY OF ARCADIA AND THE LOS ANGELES COUNTY AGRICULTURAL COMMISSIONER/WEIGHTS AND MEASURES DEPARTMENT

CEQA: Not a Project

Recommendation: Approve

SUMMARY

The existing Weed Abatement Services Agreement (“Agreement”) between the City of Arcadia and the County of Los Angeles (“County”) expires on June 30, 2024. Through the Agreement, the County is authorized to inspect vacant properties within the City and take corrective action to ensure that the properties do not become public nuisances. This Agreement permits the continuation of this activity and allows the County to provide these services in Arcadia. It is recommended that the City Council approve the renewal of the Weed Abatement Services Agreement with the County of Los Angeles for an additional five-year period from July 1, 2024, through June 30, 2029.

DISCUSSION

Under the terms of the existing Agreement, the County of Los Angeles Agricultural Commissioner/Weights and Measures Department performs weed abatement functions within the City of Arcadia. Property abatement services include the removal of weeds, brush, rubbish, and refuse from various private properties. As part of the City’s fire prevention efforts, all designated improved properties and unimproved properties that are not adequately maintained by the property owners are cleared of weeds, brush, or rubbish, as directed by the Arcadia Fire Department.

The cost of all work performed is assessed and placed on the tax roll of subject properties in the manner set forth in Government Code Sections 39573 to 39585. In addition, all properties requiring abatement are charged the current County-approved inspection fee (except tax-exempt parcels). Property owners that do not clear their property of weeds, brush, or rubbish by the given deadline or that have requested

County to clear it for them will be charged an additional fee for the required abatement work. Before any work begins, the City holds a Public Hearing for affected property owners that require abatement services, and a representative from the Los Angeles County Agricultural Commissioner's Office attends the Public Hearing to answer any questions. The abatement costs are then added to the total assessment costs and paid directly to the County by the property owner. In the absence of this Agreement, the City would become directly responsible for performing abatement services for subject properties and identifying a mechanism to recover applicable costs.

This program for abating weeds and property nuisances in Arcadia has been effective in the past, and it is recommended to continue the program through a renewal of this Agreement. The services provided by the County for the removal of weed growth and debris from vacant properties are in compliance with the County's and the City's hazardous vegetation clearance standards. Therefore, it is recommended that the City continue to contract with the County for this service.

ENVIRONMENTAL ANALYSIS

Any abatement actions proposed by the County under this Agreement are presented to the City Council through a Public Hearing, where CEQA is determined for the proposed property abatement. This proposed action for Agreement renewal does not constitute a project under the California Environmental Quality Act ("CEQA"), as it can be seen with certainty that it will have no impact on the environment.

FISCAL IMPACT

There is no direct cost to the City of Arcadia for this service, and minimal staff time is required to administer this Agreement. The inspection fee and cost of all work performed by the County is assessed and placed directly upon the tax roll of subject properties.

RECOMMENDATION

It is recommended that the City Council determine that this action does not constitute a project under the California Environmental Quality Act ("CEQA"); and approve the renewal of the Weed Abatement Services Agreement with the County of Los Angeles for an additional five-year period from July 1, 2024, through June 30, 2029.

Attachment: Proposed Weed Abatement Service Agreement

WEED ABATEMENT SERVICE

AGREEMENT

THIS AGREEMENT, dated upon execution by both parties is made by and between the County of Los Angeles, hereinafter referred to as "County," and the CITY OF ARCADIA, hereinafter referred to as "City."

RECITALS:

(a) The City is desirous of contracting with the County for the performance of weed abatement functions within its boundaries on unimproved and designated improved properties by the County of Los Angeles, acting through its Agricultural Commissioner/Director of Weights and Measures.

(b) The County is agreeable to rendering such weed abatement services on the terms and conditions hereinafter set forth in this Agreement.

(c) This Agreement is authorized and provided for by the provisions of Section 56 ½ of the Charter of the County of Los Angeles and California Government Code (Government Code) section 51301 and is permissible in accordance with Government Code sections 54980 and 54981.

THEREFORE, THE PARTIES AGREE AS FOLLOWS:

1. The County agrees, through the Agricultural Commissioner/Director of Weights and Measures, to provide weed abatement services within the corporate limits of the City in accordance with the provisions of Government Code sections 39560 through 39588.

Such services shall encompass the weed abatement duties and functions of the type coming within the jurisdiction of and customarily rendered by the Agricultural Commissioner/Weights and Measures Department of the County of Los Angeles under the Charter of County and the statutes of the State of California.

The level of service shall be the same basic level of weed abatement service that County otherwise provides for in the unincorporated areas of the County of Los Angeles by said Agricultural Commissioner/Director of Weights and Measures.

The County shall have the discretion to terminate services on tax default parcels.

The rendition of such services, the standard of performance, and other matters incidental to the performance of such services, and the control of personnel so employed shall remain at the discretion of the County.

The standard for hazardous vegetation clearance shall be equivalent to the Los Angeles County Fire Code, sections 325.2.1 and 325.2.2 being the same that applies in the unincorporated areas of the County of Los Angeles unless some other standard is requested by the City in writing and agreed to by County.

2. To facilitate the performance of said functions, it is hereby agreed that the County shall have full cooperation and assistance from the City Council and other City officer, agents, and employees.

3. For the purpose of performing said functions, County shall furnish and supply all necessary labor, supervision, equipment, and supplies necessary to maintain the level of service to be rendered hereunder.

4. The County shall perform the work contemplated with resources available within its own organization and no portion of the work shall be subcontracted, except that the County may subcontract specialized equipment and/or services pursuant to County procurement procedures using a competitive bidding process.

5. No City Employee as such shall be utilized for providing services rendered by County, and no person employed hereunder shall have any City pension, civil service, or any status or right.

For the purpose of performing such services and functions, and for the purpose of giving official status to the performance thereof where necessary, every County officer and

employee engaged in the performance of any service hereunder shall be deemed to be an officer or employee of said City while performing services for said City, which services are within the scope of this Agreement and are purely municipal functions.

6. City shall not be called upon to assume any liability for the direct payment of any salaries, wages, or other compensation to any County personnel performing services hereunder for the County, or any liability other than that provided for in this Agreement.

Except as herein otherwise specified, the City shall not be liable for compensation and/or indemnification to any County employee for any injury or sickness arising out of their employment.

7. The parties hereto have executed an Assumption of Liability Agreement approved by the Board of Supervisors on December 27, 1977 and/or a Joint Indemnity Agreement approved by the Board of Supervisors on October 8, 1991. Whichever of these documents the City has signed later in time is currently in effect and is hereby made a part of and incorporated into this Agreement as if set out in full herein. In the event that the Board of Supervisors later approves a revised Joint Indemnity Agreement and the City executes the revised Agreement, the subsequent Agreement as of its effective date shall supersede the Agreement previously in effect between the parties hereto.

The City understands and agrees that the fire protection indemnity provided in the Government Code sections 850 and 850.2 applies to the County for work pursuant to this Agreement.

8. This Agreement shall be effective commencing July 1, 2024, through June 30, 2029, unless sooner terminated as provided for herein.

The City may terminate this Agreement as of thirty-first day of December of any year upon notice in writing to the County on or before September 30 of the same year. The County may terminate this Agreement at any time and for any reason upon thirty (30) days' prior written notice to the City.

9. The City, acting through its City Council, will perform the necessary functions required of the legislative body to which is referred in Government Code sections 39560 through 39588, as they relate to the execution of this Agreement.

10. If the City fails to adopt a resolution declaring that weeds upon parcels of property located within the City to be a public nuisance pursuant to Government Code section 39561, then the County shall have no obligation to carry out its duties under this Agreement until such year that the City does adopt such resolution, unless the City's failure occurs in the final year of this Agreement, which shall mean the Agreement terminates.

11. It is the intent of this Agreement that the Agricultural Commissioner/Director of Weights and Measures of the County shall constitute the public officer designated by the City Council to perform the duties imposed by Government Code section 39560(a), and that the City Council of said City shall perform the duties of the legislative body as set forth in said section.

12. For and in consideration of the rendition of the foregoing services by the County, the City agrees that the costs of abating such weeds shall be assessed in the manner set forth in Government Code sections 39573 to 39585, and that upon collection of such assessments, they will be paid over to the County.

13. Each parcel, except tax-exempt parcels, upon which weeds, brush or rubbish are declared to be a public nuisance pursuant to paragraph 9 of this Agreement shall be assessed the current Board of Supervisors approved inspection fee whether or not it was necessary to perform abatement work upon the parcel.

14. The parties hereto contemplate that the services of the County are limited to weed abatement work and agree that such services are for no other or additional work.

15. This Agreement contains the entire Agreement between the County and the City for weed abatement services. This Agreement may not be modified except by formal amendment executed by the duly authorized representatives of the parties hereto.

16. Notices regarding this Agreement shall be addressed as follows:

COUNTY:

Adrian Zavala

Deputy Director

Los Angeles County Department of Agricultural Commissioner/

Weights & Measures

12300 Lower Azusa Road

Arcadia, California 91006-5872

CITY:

Linda Rodriguez

Office of the City Clerk

City of Arcadia

240 West Huntington Drive

Arcadia, California 91007

IN WITNESS HEREOF, the CITY OF ARCADIA, by motion duly adopted by its City Council, caused this Agreement to be signed by its Mayor and attested by its Clerk, and the County of Los Angeles, by order of its Board of Supervisors, has caused these presents to be subscribed by the Chair of said Board and seal of said Board to be affixed thereto and attested by the Clerk of the Board.

CITY OF ARCADIA

By _____
Mayor

COUNTY OF LOS ANGELES

By _____
Chair, Board of Supervisors

ATTEST:

By _____
City Clerk

ATTEST:

JEFF LEVINSON, Interim Executive Officer
Executive Office of the Board of Supervisors
of the County of Los Angeles

By _____
Deputy

APPROVED AS TO FORM:

DAWYN R. HARRISON

County Counsel

By Georgina Glaviano
Georgina Glaviano
Deputy County Counsel



STAFF REPORT

Public Works Services Department

DATE: May 7, 2024

TO: Honorable Mayor and City Council

FROM: Paul Cranmer, Public Works Services Director
By: Briget Arndell, Environmental Services Manager
Janessa Kalanjian, Management Analyst

SUBJECT: AUTHORIZE PAYMENT OF THE ANNUAL COORDINATED INTEGRATED MONITORING PROGRAM COST SHARE IN THE AMOUNT OF \$220,828.96 TO THE RIO HONDO/SAN GABRIEL RIVER WATERSHED MANAGEMENT JOINT POWERS AUTHORITY

CEQA: Not a Project

Recommendation: Approve

SUMMARY

To meet state mandated stormwater requirements, the City of Arcadia is a member of the Rio Hondo/San Gabriel River Watershed Management Joint Powers Authority (“JPA”). The formation of a JPA has alleviated regional funding complexities and acts as a management mechanism to provide liability protections to the participating cities. The JPA manages the Professional Services Agreement (“PSA”) with CWE, Inc. for the continued implementation of the Coordinated Integrated Monitoring Program (“CIMP”) Plan, which was previously managed by the City of Arcadia. The CIMP provides for a series of testing along the watershed to track water quality throughout the JPA area. The City of Arcadia will pay its portion of the annual cost share for implementation of the CIMP directly to the JPA.

It is recommended that the City Council authorize payment of the annual Coordinated Integrated Monitoring Program cost share in the amount of \$220,828.96 to the Rio Hondo/San Gabriel River Watershed Management Joint Powers Authority.

BACKGROUND

The National Pollutant Discharge Elimination System Municipal Separate Storm Sewer System Permit (“MS4 Permit”, Order No. R4-2012-0175) establishes waste discharge requirements for stormwater and non-stormwater discharges within the watersheds of Los Angeles County. The MS4 Permit was adopted by the California Regional Water Quality Control Board, Los Angeles Region (“Regional Board”), on November 8, 2012,

and became effective on December 28, 2012. The MS4 Permit includes provisions that allow permittees the flexibility to customize their stormwater programs to achieve compliance over time, through the development of an Enhanced Watershed Management Program (“EWMP”) on a watershed scale utilizing customized strategies, control measures, and Best Management Practices (BMPs) to improve water quality.

In 2013, the Cities of Arcadia, Azusa, Bradbury, Duarte, Monrovia, and Sierra Madre, along with the County of Los Angeles and Los Angeles County Flood Control District, formed the Rio Hondo/San Gabriel River Water Quality Group to fulfil the requirements of the Los Angeles County MS4 Permit. The Group included an Oversight Committee comprised of City Managers and/or their designated staff to represent each city. A Memorandum of Understanding (“MOU”) was executed by all agencies for cost sharing and the development of the EWMP and CIMP for the Rio Hondo/San Gabriel River watersheds. In July 2014, these plans were submitted to the Regional Board for approval. On June 29, 2015, the CIMP was approved.

The City of Arcadia took the lead in administering and managing the contract for implementation of the CIMP program. In December 2014, the Arcadia City Council approved a three-year contract with two, one-year optional extensions to CWE for management of the project, which expired in December 2020. On January 19, 2021, the City Council awarded a five-year PSA with CWE, Inc. for the continued implementation of the CIMP Plan for the Rio Hondo/San Gabriel Water Quality Group and executed a MOU with the cities of Bradbury, Duarte, Monrovia, and Sierra Madre, the County of Los Angeles, and the Los Angeles County Flood Control District, to aid in the administration, implementation, and cost sharing of the Agreement.

The City of Azusa was a party to the original CIMP contract in 2014; however, the City of Azusa declined to participate in the new contract. Under prior agreements, the City of Arcadia has served as the lead agency in administering and managing contracts at no cost to the participating agencies. Unlike the previous contracts, it was agreed that a Program Project Administration Fee of 5% would be charged to the Group to reimburse the City of Arcadia for contract administration. This administration fee was \$148,034 over the five-year contract period. In April 2022, the City Council approved an amendment to the agreement with CWE, Inc. to include additional requirements due to new stormwater permit requirements.

Table 1 below shows the current total cost, including original PSA amount, the change order cost reimbursing the City of Monrovia for grant preparation, and the overall administration fee for each of the participating agencies for Fiscal Years 2021-2025.

Table 1. Cost Allocation Formula for Fiscal Years 2021-2025
 (includes original PSA amount, City of Monrovia, Administration Fee (5%) and Change Order)

Agencies	Acres	Percent of Area	Base Fee (10%)	Cost based on Acres (90%)	Total Cost
City of Arcadia	11	34.16%	\$54,240.94	\$1,000,593.73	\$1,054,834.67
City of Bradbury	1.9	5.90%	\$54,240.94	\$172,829.83	\$227,070.77
City of Duarte	3.6	11.18%	\$54,240.94	\$327,467.04	\$381,707.98
City of Monrovia	8	24.84%	\$54,240.94	\$727,704.53	\$781,945.47
City of Sierra Madre	2.8	8.70%	\$54,240.94	\$254,696.59	\$308,937.53
County of Los Angeles	4.9	15.22%	\$54,240.94	\$445,719.03	\$499,959.96
Los Angeles County Flood Control District			-	-	\$167,446.13
Total	32.2	100%	\$325,445.64	\$2,929,010.74	\$3,421,902.50

For years, the Group contemplated the formulation of a JPA to meet stormwater requirements. However, discussions did not materialize until the Group’s Encanto Park Regional Project was recently funded through the County of Los Angeles’ Safe Clean Water (Measure W) program. The funding of this Regional Project brought to the forefront several complexities associated with the current structure of how the Group operates together to meet requirements. The Joint Exercise Powers Act (Government Code Section 6500, et seq.) allows two or more agencies to create another legal entity or establish a joint approach to work on a common problem, fund a project, or act as a representative body for a specific activity.

On May 17, 2022, the City Council authorized the Arcadia to participate in a Joint Exercise of Powers Agreement with the cities of Bradbury, Duarte, Monrovia, and Sierra Madre to create the Rio Hondo/San Gabriel River Watershed Management Joint Powers Authority. The JPA acts as the central hub for operational, administrative, and financial activities on behalf of the Group. In addition, it allows the Group to exercise common powers such as approving and awarding contracts; acquiring, constructing, managing, and conducting maintenance and operations for any building, structure, or capital improvement project;

seeking grants and other financial aid; obtaining insurance, participating in legislative advocacy, and conducting outreach. Due to policy limitations, the County of Los Angeles, and the Los Angeles County Flood Control District cannot be a participant in the JPA; however, both entities continue to enter into project-specific cost-share agreements with the JPA.

DISCUSSION

One of the first tasks for the JPA was to select a firm to oversee management of the JPA, including the existing contract with CWE, Inc. for the CIMP program. In May 2023, the JPA entered into a contract with KOA Consulting, Inc. ("KOA") for management of the JPA and project management of the existing agreement with CWE, Inc.

With the creation of the JPA, Arcadia no longer oversees the agreement and no longer pays CWE, Inc. directly. Furthermore, since Arcadia no longer manages the agreement, the 5% Program Project Administration Fee is no longer applicable, and all participating agencies pay their portion directly to the JPA, including Arcadia. The City of Arcadia's cost share amount for the CIMP Program for Fiscal Year 2023-24 is \$220,828.96. This is the amount the City agreed to pay as a member of the original MOU. It is recommended that the City Council authorize this payment.

ENVIRONMENTAL ANALYSIS

The proposed action of authorizing a payment to the JPA does not constitute a project under the California Environmental Quality Act ("CEQA"), as it can be seen with certainty that it will have no impact on the environment. Any environmental reviews that might be necessary would be overseen by the JPA, acting as lead agency for all efforts of the JPA.

FISCAL IMPACT

The City of Arcadia's cost share amount for the CIMP Program for Fiscal Year 2023-24 is \$220,828.96. Funds in the amount of \$221,000 are budgeted in the Fiscal Year 2023-24 Capital Improvement Program ("CIP") for the CIMP Program. The City of Arcadia is expected to receive approximately \$1,015,000 in local return from the Safe Clean Water Program (Measure W) annually and these funds have been allocated in the CIP for this contract; no General Fund monies will be utilized.

RECOMMENDATION

It is recommended the City Council determine that this action does not constitute a project under the California Environmental Quality Act ("CEQA"); and authorize payment of the Annual Coordinated Integrated Monitoring Program cost share in the amount of \$220,828.96 to the Rio Hondo/San Gabriel River Watershed Management Joint Powers Authority.

Approved:



Dominic Lazzaretto
City Manager

Attachment: Annual Coordinated Integrated Monitoring Program Cost Share Invoice



RIO HONDO/SAN GABRIEL RIVER
WATERSHED MANAGEMENT AUTHORITY

INVOICE

DATE: January 12, 2024
INVOICE NO.: 24-CIMP-01
PAYMENT IS DUE UPON RECEIPT

To: City of Arcadia
Attn: Dominic Lazaretto

**Rio Hondo/San Gabriel River Watershed Management Authority
Annual Coordinated Integrated Monitoring Program Cost Share
As Outlined Per Exhibit A and B of the MOA
Fiscal Year 2023-2024**

Description	Amount
Annual Cost Allocation for Required Services (2021-2025)	\$191,443.04
Annual Cost Allocation For Preparation of Measure W Regional Application (2021-2025)	\$4,730.86
Annual Cost for Approved Added Services (Semi-Annual Progress Reports, Toxicity Sensitivity Screening, Cultural Resources Assessment) (2023-2025)	\$24,655.07
Total Due	\$220,828.96

Please remit payment to:

(via ACH)

Wells Fargo
Account Name: RHSGR Checking
Routing Number: 121000248
Account Number: 4831818000

- or -

(via check)

Rio Hondo/San Gabriel River WMA
Attn: Koa Consulting, Inc.
419 Main Street, No. 320
Huntington Beach, CA 92648

Table 1: Cost for Original Required Services

Scope of Work Items	Years 1-3	Year 4	Year 5	Total
Project Management, Coordination, Meetings	\$ 66,099.00	\$ 14,474.00	\$ 14,474.00	\$ 95,047.00
CIMP Requirements	\$ 1,205,621.00	\$ 299,176.00	\$ 299,242.00	\$ 1,804,039.00
Health and Safety Plan	\$ 11,066.00	\$ 4,404.00	\$ 4,404.00	\$ 19,874.00
Data Management and Reporting Methodology	\$ 29,304.00	\$ 9,768.00	\$ 9,768.00	\$ 48,840.00
Laboratory Analysis	\$ 183,419.00	\$ 60,325.00	\$ 60,325.00	\$ 304,069.00
Reports	\$ 211,740.00	\$ 70,580.00	\$ 70,580.00	\$ 352,900.00
Field Logs and Site Assessment Photos	\$ 35,838.00	\$ 11,946.00	\$ 11,946.00	\$ 59,730.00
CIMP Revision	\$ 73,952.00			\$ 73,952.00
Procurement and Installation of Monitoring Equipment	\$ 202,224.00			\$ 202,224.00
Total Contract Amount				\$2,960,675.00
Contingency (10%)				\$ 296,067.50
Contract Amount Plus 10% Contingency				\$3,256,742.50

Table 2a: Costs Allocation for Required Services

Cost Formula:

A. 10% Base Fee = [(Total Consultant costs - LACFD 5% Contribution) x 10%]/6 parties]

B. 90% Land Use = [(Total Consultant costs - LACFD 5% Contribution) x 90%] x Percentage of total land area (not including Angeles Forest)

Consultant cost + 5% program project admin fee = \$3,108,708.75

Agency	Acres (Developed Land sq.mi)	Percent of Area	Base Fee (1/6 th of 10%)	Land Use (90%)	Subtotal
City of Arcadia	11	34.16%	\$49,221.22	\$907,993.97	\$957,215.19
City of Bradbury	1.9	5.90%	\$49,221.22	\$156,835.32	\$206,056.54
City of Duarte	3.6	11.18%	\$49,221.22	\$297,161.66	\$346,382.88
City of Monrovia	8	24.84%	\$49,221.22	\$660,359.25	\$709,580.47
City of Sierra Madre	2.8	8.70%	\$49,221.22	\$231,125.74	\$280,346.96
County of Los Angeles	4.9	15.22%	\$49,221.22	\$404,470.04	\$453,691.26
LACFCD (5% Contribution)	-	-	-	-	\$155,435.44
TOTAL	32.2	100	\$295,327.33	\$2,657,945.98	\$3,108,708.75

Annual costs 2021-2025
\$ 191,443
\$ 41,211
\$ 69,277
\$ 141,916
\$ 56,069
\$ 90,738
\$ 31,087
\$ 621,742

Table 2b: Costs Allocation For Preparation of Measure W Regional Application

Preparation Costs for Measure W Regional Application

\$72,980.00

Agency	Acres (Developed Land sq.mi)	Percent of Area	Base Fee (1/6 th of 10%)	Land Use (90%)	Subtotal
City of Arcadia	11	34.16%	\$1,216.33	\$22,437.95	\$23,654.28
City of Bradbury	1.9	5.90%	\$1,216.33	\$3,875.65	\$5,091.98
City of Duarte	3.6	11.18%	\$1,216.33	\$7,343.33	\$8,559.66
City of Monrovia*	8	24.84%	\$1,216.33	\$16,318.51	\$17,534.84
City of Sierra Madre	2.8	8.70%	\$1,216.33	\$5,711.48	\$6,927.81
County of Los Angeles	4.9	15.22%	\$1,216.33	\$9,995.09	\$11,211.42
TOTAL	32.2	100	\$7,298.00	\$65,682.00	\$72,980.00

Annual costs 2021-2025
\$ 4,731
\$ 1,018
\$ 1,712
\$ 3,507
\$ 1,386
\$ 2,242
\$ 14,596

* NOTE: Monrovia to receive credit \$55,445.16

Table 2c: Costs for Approved Added Services (Semi-Annual Progress Reports, Toxicity Sensitivity Screening, Cultural Resources Assessment)

Costs to be added to Years 2023-2025

Consultant Costs for Additional Services + 5% Admin Fee

\$240,213.75

Agency	Acres (Developed Land sq.mi)	Percent of Area	Base Fee (1/6 th of 10%)	Land Use (90%)	Subtotal
City of Arcadia	11	34.16%	\$3,803.38	\$70,161.81	\$73,965.20
City of Bradbury	1.9	5.90%	\$3,803.38	\$12,118.86	\$15,922.24
City of Duarte	3.6	11.18%	\$3,803.38	\$22,962.05	\$26,765.43
City of Monrovia	8	24.84%	\$3,803.38	\$51,026.77	\$54,830.16
City of Sierra Madre	2.8	8.70%	\$3,803.38	\$17,859.37	\$21,662.75
County of Los Angeles	4.9	15.22%	\$3,803.38	\$31,253.90	\$35,057.28
LACFCD (5% Contribution)					\$12,010.69
TOTAL	32.2	100	\$22,820.31	\$205,382.76	\$240,213.75

Annual costs 2023-2025
\$ 24,655
\$ 5,307
\$ 8,922
\$ 18,277
\$ 7,221
\$ 11,686
\$ 4,004
\$ 80,071

Table 3: Annual Invoice Schedule

Agency	January 2021	January 2022	January 2023	January 2024	January 2025
City of Arcadia	\$ 196,173.89	\$ 196,173.89	\$ 220,828.96	\$ 220,828.96	\$ 220,828.96
City of Bradbury	\$ 42,229.70	\$ 42,229.70	\$ 47,537.12	\$ 47,537.12	\$ 47,537.12
City of Duarte	\$ 70,988.51	\$ 70,988.51	\$ 79,910.32	\$ 79,910.32	\$ 79,910.32
City of Monrovia*	\$ 89,977.90	\$ 145,423.06	\$ 163,699.78	\$ 163,699.78	\$ 163,699.78
City of Sierra Madre	\$ 57,454.95	\$ 57,454.95	\$ 64,675.87	\$ 64,675.87	\$ 64,675.87
County of Los Angeles	\$ 92,980.54	\$ 92,980.54	\$ 104,666.30	\$ 104,666.30	\$ 104,666.30
LACFCD (5% Contribution)	\$ 31,087.09	\$ 31,087.09	\$ 35,090.65	\$ 35,090.65	\$ 35,090.65
TOTAL	\$ 580,892.59	\$ 636,337.75	\$ 716,409.00	\$ 716,409.00	\$ 716,409.00

* Monrovia received a credit of \$55,445.16 that was applied against \$145,423.06 for the 2021 invoice



STAFF REPORT

Public Works Services Department

DATE: May 7, 2024

TO: Honorable Mayor and City Council

FROM: Paul Cranmer, Public Works Services Director
By: Carlos Aguilar, General Services Superintendent

SUBJECT: PURCHASE ORDER WITH BLACK & WHITE EMERGENCY VEHICLES, LLC FOR THE PURCHASE OF VEHICLE OUTFITTING SUPPLIES AND SERVICES IN THE AMOUNT OF \$142,695.86

CEQA: Not a Project

Recommendation: Approve

SUMMARY

The Public Works Services Department (“PWSD”) is responsible for outfitting new fleet vehicles with safety lighting, radio communication systems, and other job-specific specialty equipment. This outfitting service is performed by an outside vendor. To ensure that the City is receiving the most competitive price for outfitting supplies and services, a formal bid process was conducted and Black and White Emergency Vehicles, LLC submitted the lowest responsive bid. It is recommended that the City Council approve a purchase order with Black and White Emergency Vehicles, LLC for the purchase of vehicle outfitting supplies and services in the amount of \$142,695.86, with the option of three, one-year renewals.

BACKGROUND

The PWSD is responsible for the purchase of fleet vehicles listed in the City’s annual Equipment Replacement Plan. When new police pursuit vehicles, service trucks, and miscellaneous vehicles are purchased, they are sent to an outside vendor for vehicle outfitting, which includes the installation of safety lighting, radio communication systems, and other job-specific specialty equipment. Police pursuit vehicles are outfitted with a prisoner seat, acrylic partition, push bar, gun mounts, and lights and sirens. The service trucks and other miscellaneous vehicles are sent to the vendor to be equipped with safety lights and a City issued two-way radio. After the vendor has installed all outfitting related equipment, the vehicle is placed in service.

DISCUSSION

Initially, a bid for emergency lighting and supplies was advertised on March 11, 2024.

Bids were due on March 26, 2024, but no bids were received. A Notice Inviting Bids was published once more in accordance with City Council Resolution No. 7483, and bid packages were distributed to eight vehicle outfitting vendors. On April 16, 2024, the City Clerk opened one sealed bid with the following results:

Company	Location	Bid Amount
Black & White Emergency Vehicles, LLC	Azusa, CA	\$142,695.86

Staff contacted the vendors that received the notice inviting bids to find out why they did not submit a bid. The responses received indicated that vendors either did not have the ability to provide all of the emergency lighting and supplies needed, they are providing these items to other agencies and are backlogged, or they were not interested in responding to the bid. The City has worked with Black & White Emergency Vehicles, LLC since 2013 and they have consistently provided the lowest pricing on other project bids.

The bid document received by Black & White Emergency Vehicles, LLC was reviewed for content and the vendor's ability to meet the City's needs as described in the bid specifications. Based on the evaluation of the bid, it was concluded that Black and White Emergency Vehicles, LLC is a responsive bidder. Given the routine nature of this agreement, it is recommended that the optional three, one-year extensions be at the discretion of the City Manager, without the need for additional City Council approval.

ENVIRONMENTAL ANALYSIS

The proposed action does not constitute a project under the California Environmental Quality Act ("CEQA"), as it can be seen with certainty that it will have no impact on the environment.

FISCAL IMPACT

Sufficient funds have been budgeted in each Department's proposed Fiscal Year 2024-25 Equipment Replacement Fund for the purchase of vehicle outfitting supplies and services.

RECOMMENDATION

It is recommended the City Council determine that this action does not constitute a project under the California Environmental Quality Act ("CEQA"); and approve a Purchase Order with Black and White Emergency Vehicles, LLC for the purchase of vehicle outfitting supplies and services in the amount of \$142,695.86, with the option of three, one-year renewals at the discretion of the City Manager.

Award Purchase Order for Vehicle Outfitting Supplies and Services
May 7, 2024
Page 3 of 3

Approved:



Dominic Lazzaretto
City Manager



STAFF REPORT

Public Works Services Department

DATE: May 7, 2024

TO: Honorable Mayor and City Council

FROM: Paul Cranmer, Public Works Services Director
By: John Corona, Utilities Superintendent

SUBJECT: PURCHASE ORDER WITH INDUCTIVE AUTOMATION, LLC FOR THE PURCHASE OF IGNITION SCADA PLATFORM SOFTWARE IN THE AMOUNT OF \$47,901.20

CEQA: Not a Project

Recommendation: Approve

SUMMARY

The City of Arcadia Public Works Services Department (“PWSD”) uses Supervisory Control and Data Acquisition software, commonly referred to as “SCADA”, to monitor the City’s water system equipment. The current SCADA system is proprietary software, which operates on outdated technology that is no longer supported and needs to be replaced. City staff performed an audit of existing equipment and available SCADA software systems and determined that Ignition SCADA Platform provided by Inductive Automation, is the most compatible SCADA software with Arcadia’s water system.

It is recommended that the City Council approve a sole source purchase order with Inductive Automation, LLC for the purchase of the Ignition SCADA Platform software in the amount of \$47,901.20.

BACKGROUND

The City of Arcadia water system contains 11 groundwater wells, 33 booster pumps, 15 reservoirs, and two forebays. Each water site contains various computer systems that operate and monitor the wells, boosters, and overall activity for each site. Because the water sites are operating 24 hours a day, it is necessary to constantly monitor the systems and address emergencies remotely and in real time. All modern water systems use SCADA to monitor and remotely control each aspect of their water system. SCADA systems provide real time monitoring data, alarm reporting, historical data mining, and remote-control access to make necessary adjustments to each component of the water system. SCADA systems must be compatible with various types of equipment, be user-friendly for water system operators, and offer robust and available technical support.

The City has used the current software system, Genesis32 SCADA, for over 25 years. Genesis32 is proprietary software that has not been maintained for over 10 years and operates on outdated 32-bit Microsoft technology, which is difficult to find technical support for. While the software has been compatible with our equipment thus far, it is not guaranteed that the software will be able to work with future upgrades to the system. Should there be any significant failures to the software, it will be difficult to find a technician familiar with Genesis32 and is considered obsolete compared to newer SCADA software programs on the market today. To keep the water system operating at optimal levels, it is necessary to replace the SCADA system with newer software that operates on updated technology. Transitioning to SCADA software that is more widely used will enable faster technical assistance, so the water system can be monitored on a 24-hour basis and quickly repaired when issues arise.

DISCUSSION

To determine which SCADA software would be most suitable for the City's water system, the PWSD worked with a technical consultant to perform an audit of the current SCADA system and water system equipment. The SCADA audit reviewed all equipment currently used at each water site, the technical specifications needed for compatibility, and identified the deficiencies in the current Genesis32 system. The audit determined that while there are other SCADA systems on the market that would be compatible with our water system, Ignition Platform, provided by Inductive Automation, best meets the needs to address the insufficiencies of the current Genesis32 system.

Inductive Automation has been in the industry for over 20 years and is one of the top SCADA software providers. They are the sole provider of Ignition Software and exclusively hold the source code for licensing of the software. Ignition Software is a commonly used SCADA system and uses the latest technology. The software is compatible with all existing equipment and will require minimal hardware upgrades during the initial installation. Another advantage of Ignition Platform includes the many companies that provide technical assistance for the software. By using the Ignition Platform, the City would not be reliant on the provider as the only source of technical support. Ignition Platform will address the inadequacies of the current SCADA software and provide reliable service. For these reasons, it is recommended that the City enter into a sole source contract for these services and the new software.

ENVIRONMENTAL ANALYSIS

The proposed action of updating software does not constitute a project under the California Environmental Quality Act ("CEQA"), as it can be seen with certainty that it will have no impact on the environment.

FISCAL IMPACT

Sufficient funds are available in the Department's Fiscal Year 2023-24 Operating Budget for the initial purchase price of \$47,901.20 for the Ignition Platform software. Funds will be budgeted in subsequent fiscal years for software maintenance and upgrades as needed.

RECOMMENDATION

It is recommended that the City Council determine that this action does not constitute a project under the California Environmental Quality Act ("CEQA"); and approve a Purchase Order with Inductive Automation, LLC for the purchase of the Ignition SCADA Platform software in the amount of \$47,901.20.

Approved:



Dominic Lazzaretto
City Manager

Attachments: Inductive Automation, LLC Sole Source Letter
Proposed Software Quote

28 February 2024

RE: SOLE SUPPLIER REQUIREMENT

To Whom It May Concern:

This letter is to confirm that Inductive Automation, LLC is the sole supplier of Ignition Software. Inductive Automation exclusively holds the source code relating to the licensing of Ignition Software and develops it here in Folsom, California.

Ignition's unique license model allows customers to connect unlimited devices, users, databases, and tags. Ignition's cross-platform compatibility allows visualizations on any device. Additionally, Ignition is built on open standard technologies such as SQL, Python, MQTT, and OPC UA. Furthermore, Ignition includes a Designer to build out applications.

Ignition's modular approach allows customers to build any kind of industrial application. The Perspective module allows users to create mobile responsive industrial applications. The SQL Bridge module can bridge the gap between OPC data and SQL databases. The Tag Historian module turns any SQL database into a high-performance time-series tag historian. The Alarm Notification module uses programmable logic to determine how, why, and when alarm notifications are processed. Furthermore, users can manage alarm notifications for groups of users and send notifications via email.

All modules are installed into the Ignition Platform. Core Drivers are also included to connect to a variety of devices, handle security, store and forward data, create redundancy, and monitor system capabilities. Ignition provides an unrivaled fully integrated systems platform.

Please contact us if you have questions or need further information.

Regards,

DocuSigned by:

427F87BA396945F...
Kevin McClusky
VP of Sales

Quote #1312879

Quote valid: January 30, 2024 - March 30, 2024
 Payment Terms: Net 30

Bill To:

City of Arcadia
 John Corona
 11800 Goldring Rd
 Arcadia, CA 91007
 US

Ship To:

City of Arcadia
 John Corona
 11800 Goldring Rd
 Arcadia, CA 91007
 US

Product	Price	Qty	Total
Ignition Custom Package 8.1 - Ignition Platform - OPC UA Server Module - Core Drivers - Alarm Notification Module - Voice Notification - English Female (Katherine) - Voice Notification Module - SMS Notification Module - SQL Bridge Module - Tag Historian - Perspective Module - Symbol Factory - Reporting Module	\$24,970.00	1	\$24,970.00
Ignition Custom Package 8.1 - Redundancy - Ignition Platform - OPC UA Server Module - Core Drivers - Alarm Notification Module - Voice Notification - English Female (Katherine) - Voice Notification Module - SMS Notification Module - SQL Bridge Module - Tag Historian - Perspective Module - Symbol Factory - Reporting Module	\$12,485.00	1	\$12,485.00
BasicCare Support Plan: ALISO VIEJO, CA Term: Nov 20, 2023 - Feb 17, 2025 Includes 90 days of free Post-Sales Support Best for customers who want access to technical support reps via email, but don't require that issues be expedited via phone support. Includes free upgrades to any modules purchased, plus email and web support.	\$5,992.80	1	\$5,992.80

THIS QUOTE, AND ANY RELATED SALE, IS NULL AND VOID IF ALTERED IN ANY MANNER BY ANYONE OTHER THAN AUTHORIZED INDUCTIVE AUTOMATION PERSONNEL. THIS QUOTE IS VALID ONLY TO THE PARTY TO WHOM IT IS ISSUED AND IS NOT VALID AND MAY NOT BE TRANSFERRED TO ANY OTHER PARTY

Quote #1312879

Quote valid: January 30, 2024 - March 30, 2024
Payment Terms: Net 30

Price	\$43,447.80
Subtotal	\$43,447.80
Sales Tax	\$0.00
<hr/>	
Total	\$43,447.80 USD

Comments

The software is delivered electronically.

If you have any questions, please contact:

Amardeep (Amar) Kahlon
Technical Sales Representative
akahlon@inductiveautomation.com
1.916.302.1289 (Direct line)
1.800.266.7798 ext. 284 (Within USA)
1.916.456.1045 ext. 284 (International)

Notes

This quote was generated on January 30, 2024

THIS QUOTE, AND ANY RELATED SALE, IS NULL AND VOID IF ALTERED IN ANY MANNER BY ANYONE OTHER THAN AUTHORIZED INDUCTIVE AUTOMATION PERSONNEL.
THIS QUOTE IS VALID ONLY TO THE PARTY TO WHOM IT IS ISSUED AND IS NOT VALID AND MAY NOT BE TRANSFERRED TO ANY OTHER PARTY



STAFF REPORT

Public Works Services Department

DATE: May 7, 2024

TO: Honorable Mayor and City Council

FROM: Paul Cranmer, Public Works Services Director
By: John Corona, Utilities Superintendent

SUBJECT: PURCHASE ORDER WITH CALGON CARBON CORPORATION FOR CARBON EXCHANGE SERVICES FOR THE LIVE OAK GAC TREATMENT SYSTEM IN THE AMOUNT OF \$212,562
CEQA: Exempt
Recommendation: Approve

SUMMARY

The Public Works Services Department (“PWSD”) is responsible for the daily operation of City wells and the water that is distributed to the community. Water quality samples are taken regularly to ensure optimal water quality. In October 2018, water quality samples at Live Oak Well indicated that the well was impacted by Trichloroethylene (“TCE”), a volatile organic compound. Since TCE concentrations at Live Oak Well exceeded the allowable standards, a treatment system using Granular Activated Carbon (“GAC”) to remove TCE was constructed. Based on the State Water Resources Control Board (“SWRCB”) permit for operations, when the effectiveness of the GAC system wanes, new carbon filters must be installed.

It is recommended that the City Council approve a Purchase Order with Calgon Carbon Corporation for Carbon Exchange Services for the Live Oak GAC Treatment System in the amount of \$212,562.

BACKGROUND

The PWSD operates the City’s water distribution system, which provides water service to more than 56,000 residents through approximately 14,000 service connections. The City uses groundwater wells as the primary source of water supply to meet the demands of water use in the Arcadia. Water quality samples are taken regularly to ensure optimal water quality.

In October 2018, water quality samples at Live Oak Well indicated that the well was impacted by TCE, a volatile organic compound. TCE is a federal and state regulated contaminant with a Maximum Contaminant Level (“MCL”) of 5 parts per billion. Since TCE

concentrations at Live Oak Well exceeded the allowable MCL, it was determined that a treatment system to treat TCE would need to be constructed. On February 5, 2019, the City Council approved, authorized, and directed the City Manager to execute a Professional Services Agreement (“PSA”) with Calgon Carbon Corporation for the construction of a GAC Adsorption System for Live Oak Well.

DISCUSSION

In July 2021, the City began operating the Live Oak GAC treatment system to remove TCE from the Live Oak Well aquifer. The GAC Adsorption System uses the granular active carbon to remove TCE through an adsorption process. Once the surface of the carbon vessels become completely saturated, it is necessary to remove the carbon vessels from service. Once the vessels are removed, they are reactivated offsite where they are stored for future use, specifically for the Live Oak facility; this process is defined as Carbon Exchange. Based on contaminant levels documented in 2018, it was estimated that the GAC Adsorption System would need to be exchanged every 16 months. The first carbon exchange occurred in December 2022. The four lead vessels have again reached their carbon saturation level and need to be exchanged. The timing of this exchange is directly on schedule, remaining within the 16-month estimated saturation period. It is crucial for the Live Oak Well to remain operational as it is a top producing well. Furthermore, based on the SWRCB permit for operations, once the GAC lead vessels experience contaminant breakthrough, a mandatory GAC exchange must be scheduled.

Calgon Carbon Corporation was awarded the original contract to supply the GAC for the treatment system. The GAC provided is specific to Arcadia’s treatment needs and will be recycled for reuse only at the Live Oak Treatment facility. Due to these specific requirements and to avoid any possible cross contamination, Calgon Carbon Corporation meets the criteria to be considered a sole source provider.

ENVIRONMENTAL ANALYSIS

This project is considered a Class 1 exemption as defined in Section 15301(b) & (d) of the California Environmental Quality Act (“CEQA”), since the project consists of restoration or rehabilitation of deteriorated or damaged facilities to meet current standards of public health and safety. This project is categorically exempt per the California Environmental Quality Act as an existing facility, Section 15301 of the CEQA guidelines.

FISCAL IMPACT

Sufficient funds have been budgeted in the Fiscal Year 2023-24 Water Operating Budget. The total cost to exchange all four lead vessels is \$212,562.

RECOMMENDATION

It is recommended that the City Council determine that this project is a Class 1 exemption under the California Environmental Quality Act (“CEQA”); and approve a Purchase Order with Calgon Carbon Corporation for Carbon Exchange Services for the Live Oak GAC Treatment System in the amount of \$212,562.

Approved:



Dominic Lazzaretto
City Manager

Attachment: Proposed Carbon Exchange Quote



CALGON CARBON CORPORATION

Activated Carbon Scope Of Supply For City of Arcadia, CA – Live Oak Treatment Plant

Contact: John Corona	Email: jcorona@arcadiaca.gov
Project: Live Oak Plant Carbon Exchange	Date: 4/11/2024
Location: 630 Live Oak Ave Arcadia, CA 91006	Title: Utilities Superintendent

GAC Volume: Filtrasorb 400 - 80,000 lbs.
GAC Turnkey Exchange Pricing: \$2.41/lb. (excludes applicable sales tax)

ITEMS INCLUDED:

- Product: Filtrasorb 400 Bulk
- Quantity: 80,000 lbs.
- Scope: Calgon Carbon Corporation to perform 80,000 lbs Filtrasorb 400 exchange using CAN 7120N scope to include backwash trailer to assist with fines removal
- All related labor and equipment (trucks, hoppers, hoses, etc), except utilities detailed below

ITEMS NOT INCLUDED IN THIS OFFER:

- Owner to provide clean water source for movement of GAC to and from filter via eduction
- Drain access for excess water from carbon transfer (water will be gray with carbon fines)
- Disinfection (if necessary) not included
- Any applicable taxes not included

SPECIAL TERMS AND CONDITIONS:

1. Unless otherwise noted, or until other Terms and Conditions are provided, this Offer is made only under Calgon Carbon Corporation's General Terms and Conditions for Purchase.
2. Pricing provided is exclusive of any Sales Tax.
3. Scope of Supply/Pricing does not include any Payment or Performance Bonds. Costs for any such Bond (if necessary or requested by the Purchaser) will be added to the quoted pricing.
4. Upon acknowledgement of any Purchase Order, the Buyer will be requested to complete a Credit Application and provide Tax Exemption Documentation.
5. The quoted price is valid for until December 31st, 2024.

For Information or to Place an Order, Contact:

Bryan Rodriguez
Calgon Carbon Corporation
Technical Sales Representative
bryan.rodriguez@kuraray.com
412-352-7612



STAFF REPORT

Fire Department

DATE: May 7, 2024

TO: Honorable Mayor and City Council

FROM: Chen Suen, Fire Chief
By: Tom Devlin, Battalion Chief
Maria Lourdes Taylor, Sr. Management Analyst

SUBJECT: REJECT BID FROM COAST-TO-COAST CUSTOM MOBILE, AND APPROVE A PURCHASE ORDER WITH GLENDORA CHEVROLET FOR THE PURCHASE OF ONE 1/2-TON 2024 CHEVROLET FOUR-WHEEL DRIVE TAHOE IN THE AMOUNT OF \$76,828

CEQA: Not a Project

Recommendation: Approve

SUMMARY

The Fiscal Year 2023-24 Equipment Acquisition Budget provides for the purchase of one new utility vehicle for the Fire Department. To ensure that the City is receiving the most competitive pricing for the purchase of this vehicle, three attempts of a formal bid process were conducted in November 2023, December 2023, and March 2024. The November 2023 and December 2023 competitive bidding were for the vehicle functionalities offered by a 3/4-ton four-wheel drive (“4WD”) crew cab pick-up truck. Unfortunately, no bids were received in November 2023, and during the second bid process in December 2023, only one bid was submitted by Coast-to-Coast Custom Mobile. The bid submitted by Coast-to-Coast Custom Mobile was for \$126,681, which was 50% higher than the manufacturer’s suggested retail price and was not within budget.

For the third and final bid in March 2024, it was determined that a new 1/2-ton 2024 4WD Chevrolet Tahoe has comparable vehicle features that could meet the Fire Department’s utility vehicle specifications for less cost. Glendora Chevrolet was deemed the most responsive bidder during the third and final bid process. It is recommended that the City Council reject the high bid from Coast-to-Coast Custom Mobile, and approve a Purchase Order with Glendora Chevrolet for the purchase of a 1/2-ton 2024 Chevrolet 4WD Tahoe in the amount of \$76,828.

BACKGROUND

As part of a new program introduced by the Fire Department during the City’s FY 2023-

24 Budget Adoption, \$100,000 was allocated from the Equipment Acquisition Budget for the purchase of one new utility truck for the Fire Department. This vehicle was intended to support daily operations by transporting Fire personnel and their safety equipment as well as hauling various materials. This vehicle will also be utilized in supporting single-resource or team deployments during a wildland firefighting response.

Originally, the vehicle identified to deliver these operational and functional features was a 3/4-ton four-wheel drive (“4WD”) crew cab pick-up truck. In November 2023, the first formal bid was issued with no bids received. A second formal bid was executed in December 2023, with one bid submitted by Coast-to-Coast Custom Mobile vendor for \$126, 681, nearly 30% over budget and almost 50% higher than the manufacturer’s suggested retail price of \$85,000. After examination of the two previous bid results and further consideration of the current market for a 3/4-ton 4WD crew cab truck, it was concluded that pursuing this vehicle model is not the most fiscally responsible option.

The third and final formal bid process proceeded in March 2024. Prior to commencing the third bid process, staff determined that a 1/2-ton Chevrolet 4WD Tahoe has comparable vehicle specifications that still align with the Fire Department’s operational needs, and cost significantly less than a 3/4-ton 4WD crew cab truck.

DISCUSSION

A Notice Inviting Bids were published in accordance with City Council Resolution No. 7483, and bid packages were distributed to local vendors during the three formal bidding periods: November 2023, December 2023, and March 2024. No bid was received in November 2023, and in December 2023, only one bid was provided from Coast-to-Coast Custom Mobile totaling \$126,6801, for the purchase of a 3/4-ton 4WD crew cab pick-up truck. Due to the exceedingly high quote from Coast-to-Coast Custom Mobile, it is recommended that the City Council reject this bid.

Based on two unsuccessful bid outcomes, the third and final bid process was conducted in March 2024 with the following results:

Bidder	Location	Bid Amount
Sierra Chevrolet of Monrovia*	Monrovia, CA	\$ 76,300
Glendora Chevrolet	Glendora, CA	\$ 76,828
Premier Chevrolet	Buena Park, CA	\$ 85,600

**Non-responsive bid due to its inability to meet the vehicle’s bid specification requirements*

One of the required specifications items in the City’s bid is the vendor’s ability to offer a timely delivery of a new utility vehicle with a red exterior color. Although Sierra Chevrolet of Monrovia was the lowest bidder, they were unable to offer the required color, thus, their bid was deemed unresponsive. The second lowest bid was submitted by Glendora Chevrolet, whose background and proposal were thoroughly evaluated. Glendora

Reject Bid and Purchase One 2024 Chevrolet 4WD Tahoe

May 7, 2024

Page 3 of 3

Chevrolet's bid meets the Fire Department's vehicle specification and budget requirements, and they can deliver the vehicle immediately. Based on this review, it was confirmed that Glendora Chevrolet was the lowest responsive bidder.

ENVIRONMENTAL ANALYSIS

The proposed action does not constitute a project under the California Environmental Quality Act ("CEQA"), as it can be seen with certainty that it will have no impact on the environment.

FISCAL IMPACT

The total cost to purchase a new 1/2-ton 2024 Chevrolet 4WD Tahoe vehicle is \$76,828. Sufficient funds in the amount of \$100,000 have been allocated in the FY 2023-24 Equipment Acquisition Budget for the purchase of this vehicle and its related upfitting costs.

RECOMMENDATION

It is recommended that the City Council determine that this action does not constitute a project under the California Environmental Quality Act ("CEQA"); and that the City Council reject the bid from Coast-to-Coast Custom Mobile, and approve a Purchase Order with Glendora Chevrolet for the purchase of a one 1/2-ton 2024 Chevrolet Four-Wheel Drive Tahoe in the amount of \$76,828.

Approved:



Dominic Lazzaretto
City Manager



STAFF REPORT

Office of the City Manager

DATE: April 16, 2024

TO: Honorable Mayor and City Council

FROM: Dominic Lazzaretto, City Manager
By: Justine Bruno, Deputy City Manager

SUBJECT: REPORT, DISCUSSION AND DIRECTION REGARDING POTENTIAL MODIFICATIONS TO THE CITY COUNCIL MEETING SCHEDULE
CEQA: Not a Project
Recommendation: Amend Summer Meeting Schedule

SUMMARY

Within the limits of the Arcadia City Charter, the City Council meeting schedule is intended to meet the workload and scheduling needs of the elected body. Regular Meetings are held on the first and third Tuesday of each month. For the past three years, the City Council has been operating under an amended schedule in the months of January, July, and August, where the first meeting of those months is skipped. While this modified schedule has worked, it would be more effective and efficient to hold both meetings in August and instead skip the first meeting in September, which is typically the day after the Labor Day holiday. It is recommended that the City Council modify the existing meeting schedule to skip the first meeting in the months of January, July, and September.

DISCUSSION

Within the limits of the City Charter, regular City Council meetings shall occur at least twice a month, unless otherwise cancelled, and no more than four regular meetings shall be cancelled in a fiscal year.

The City Council hosts its Regular Meetings on the first and third Tuesday of each month. For many years, the City Council had opted to cancel the first meeting in January each year to accommodate a slower time over the winter holidays. In addition, the City Council's meeting schedule was modified in October 2021, where it was determined that the Regular Meeting on the first Tuesday in July and August would be also cancelled. The impetus for cancelling the first Regular Meeting during these months was to officially recognize the cancellations that had already been occurring due to holiday and summer travel conflicts. The official cancellation of these three meetings was undertaken to recognize a practice that was already occurring and provide a better mechanism to plan for the business of the City Council.

In October 2021, City Council agreed that having a set meeting schedule with known cancellations provided for a level of certainty and pre-planning they desired. Additionally, the Mayor, or three members of the City Council, can call a Special Meeting at any time, providing the flexibility to continue meeting business needs. Since this change was formalized in October 2021, the new meeting schedule has been effective in allowing the City Council and staff to plan their workload and time away from the office, accordingly.

After several years operating under the new format, it appears that shifting the schedule slightly would be more effective. The first City Council meeting in September typically occurs the day after the Labor Day Holiday. City Council Meetings held immediately following a national holiday tend to yield lower attendance, a light meeting agenda, and, most often, a scheduling conflict among the City Council or staff. In addition, it is very common for staff and the public to take their summer vacations the week before Labor Day in order to get one additional day. This leads to difficulty in writing staff reports and getting information from consultants and contractors in the time leading up to a meeting date. In addition, cancelling meetings in consecutive months creates scheduling complexities with appeals hearings. Finally, cancelling consecutive monthly meetings near the start of the Fiscal Year also makes it difficult to establish contracts that are needed to begin implementing the adopted City budgetary programs and projects.

Due to these circumstances, it is recommended that City Council consider modifying the meeting schedule by moving the cancellation of the August meeting to the first meeting of September. The proposed change will keep City Council meetings from occurring the day after the national holiday and would create a longer spread between cancelled meetings. To maintain the balance of the existing workload needs, adding another cancellation to the current Regular Meeting schedule is not recommended. Should the City Council agree to adjusting the meeting schedule, it would go into effect this summer.

ENVIRONMENTAL ANALYSIS

The proposed action does not constitute a project under the California Environmental Quality Act ("CEQA"), as it can be seen with certainty that it will have no impact on the environment.

FISCAL IMPACT

There is no fiscal impact resulting from the proposed change to the City Council meeting schedule.

RECOMMENDATION

It is recommended that the City Council find that the proposed action does not constitute a project under the California Environmental Quality Act ("CEQA"); and modify the existing meeting schedule to skip the first meeting in the months of January, July, and September.